

| | |
|---|------------|
| Product Range & Packaging | 2 |
| Merchandising | 3 |
| Vehicle Application List | 5 |
| Car & Light Commercial | 6 |
| Truck, Earthmoving, Tractor & Equipment | 56 |
| Thermostats | 86 |
| Function | 87 |
| High Flow Thermostats | 87 |
| Thermostat Style & Selection | 88 |
| Thermostat Installation | 89 |
| Thermostat Temperature | 90 |
| Jiggle Pin | 90 |
| Frequently Asked Questions | 91 |
| Testing Procedure | 92 |
| Thermostat Calibration | 93 |
| Thermostat Identification Guide | 94 |
| Thermostat Size - Quick Reference Guide | 127 |
| Thermostat Gaskets | 137 |
| Function | 138 |
| Thermostat Gasket Styles | 138 |
| Gasket Identification Guide | 139 |

Tridon Guarantee

Tridon Thermostats listed in this catalogue are guaranteed to be free of defects in materials and workmanship for the period 3 years or 50,000km.

This guarantee does not apply to:

- Products that have been modified or altered in any way
- Products that have been physically damaged or misused
- Products that have not been fitted in the correct vehicle application
- Products that have not been fitted correctly
- Misdiagnosis



Thermostats and Gaskets

Product Range

Thermostats

The thermostat is a mechanical temperature control valve assembly used in the vehicle cooling system to regulate the temperature of the engine. The thermostat allows the circulation of coolant from the engine through the radiator once the predetermined temperature is achieved.

High Flow Thermostats



The high flow thermostat is designed to interchange with the original thermostat. Utilising a **30% larger** opening valve, the high flow thermostat increases coolant flow and improves cooling system performance. Ideal for high performance applications, or for applications where additional loads are placed on the engine.

Thermostat Gaskets

The thermostat gasket is designed to seal the water inlet or thermostat housing to the engine. There are two styles of thermostat gaskets, paper or moulded rubber 'O' rings (sealing rings). Some manufacturers use neither style, rather a liquid sealing compound between the two metal surfaces.

Packaging

Tridon thermostats are available blister packed or boxed (due to size certain thermostats are available boxed only). High flow thermostats have a unique, distinctive design to enable quick and easy identification. Thermostat gaskets are supplied in a carded, sealed poly bag. To assist with correct product selection an abbreviated application list is supplied on the back of each backing card. The part number is clearly marked on the front of the pack and is barcoded.

Always refer to the catalogue application list or Tridon Part Finder at www.tridon.com.au/partfinder for more comprehensive applications.



Merchandising

Tridon's thermostat merchandising panels are designed for wall or gondola mounting. Each merchandiser contains a selection of popular, fast moving thermostats suitable for the automotive repairer.

Panel Dimensions: 480mm (w) x 380mm (h)

Thermostat Merchandiser

Popular, fast moving thermostat part numbers.

Ideal for the workshop servicing a mix of popular vehicles.

Contains 8 part numbers with 13 thermostats in total.

Contents: Part No. TTM13

| Part No. | Qty | Part No. | Qty |
|-----------|-----|-----------|-----|
| TT1-180 | 2 | TT228-195 | 2 |
| TT1-192 | 1 | TT240-180 | 2 |
| TT203-195 | 2 | TT240-192 | 1 |
| TT214-180 | 2 | TT241-180 | 1 |



Thermostat Merchandiser - High Flow Upgrade

High flow upgrade for standard thermostat merchandiser.

Ideal for the workshop servicing a mix of popular high performance vehicles.

Contains 8 part numbers with 13 thermostats in total.

Contents: Part No. TTM13-UG

| Part No. | Qty | Part No. | Qty |
|------------|-----|------------|-----|
| TT2000-180 | 2 | TT2028-195 | 2 |
| TT2000-195 | 1 | TT2040-180 | 2 |
| TT2003-195 | 2 | TT2040-192 | 1 |
| TT2014-180 | 2 | TT2041-180 | 1 |



High Flow Thermostat Merchandiser

Popular, fast moving high flow thermostat part numbers.

Ideal for the workshop servicing a mix of popular vehicles with only high flow applications.

Contains 7 part numbers with 10 thermostats in total.

Contents: Part No. TTM10

| Part No. | Qty | Part No. | Qty |
|-----------|-----|-----------|-----|
| TT268-170 | 2 | TT301-180 | 1 |
| TT281-180 | 2 | TT323-180 | 1 |
| TT294-170 | 2 | TT373-180 | 1 |
| TT298-180 | 1 | | |



Thermostats and Gaskets

Merchandising

Thermostat Gasket Merchandiser

Comprehensive range of paper and rubber gaskets to suit passenger cars and light commercial vehicle applications. Vehicle application details are listed on the backing card for easy identification.

Contains 62 part numbers with 161 gaskets in total.

Shelf space requirements are minimal.

Dimensions: 315mm (d) x 625mm (w) x 450mm (h)

Contents: Part No. TGM3

| Part No. | Qty | Part No. | Qty | Part No. | Qty | Part No. | Qty |
|----------|-----|----------|-----|----------|-----|--------------|------------|
| TTG1U | 4 | TTG17 | 2 | TTG33 | 3 | TTG49 | 3 |
| TTG2U | 4 | TTG18 | 3 | TTG34 | 4 | TTG50 | 1 |
| TTG3 | 3 | TTG19 | 3 | TTG35 | 3 | TTG51 | 3 |
| TTG4 | 3 | TTG20U | 4 | TTG36 | 2 | TTG55 | 2 |
| TTG5 | 3 | TTG21 | 2 | TTG37 | 1 | TTG56 | 2 |
| TTG6 | 1 | TTG22 | 2 | TTG38 | 3 | TTG57 | 1 |
| TTG7 | 3 | TTG23 | 2 | TTG39 | 2 | TTG58 | 2 |
| TTG8 | 1 | TTG24 | 3 | TTG40 | 3 | TTG63 | 2 |
| TTG9 | 4 | TTG25 | 5 | TTG41 | 2 | TTG69 | 2 |
| TTG10 | 3 | TTG26 | 3 | TTG42 | 3 | TTG71 | 2 |
| TTG11 | 6 | TTG27 | 1 | TTG43 | 3 | TTG72 | 1 |
| TTG12 | 3 | TTG28 | 2 | TTG44 | 2 | TTG73 | 1 |
| TTG13 | 1 | TTG29U | 3 | TTG45 | 3 | TTG75 | 1 |
| TTG14 | 4 | TTG30 | 2 | TTG46 | 5 | TTG77 | 2 |
| TTG15 | 4 | TTG31 | 2 | TTG47 | 5 | Total | 161 |
| TTG16 | 3 | TTG32 | 1 | TTG48 | 2 | | |





This section assists in identifying the correct product from the range of Tridon thermostats. A diagram of each series (not to scale) shows dimensions in millimetres. Commencement to open temperature of each thermostat is shown in °C.

The last three digits of the part number are the opening temperature in °F. The fully open temperature is approximately 12°C above the commencement to open temperature or crack point of the thermostat. Always refer to the vehicle application list for the correct thermostat.

For packaging and merchandising details refer to pages 2 and 3.

Thermostats Standard & High Flow



Function

The thermostat is a mechanical temperature control valve assembly used in the vehicle cooling system to regulate the temperature of the engine. The thermostat allows the circulation of coolant from the engine through the radiator once the predetermined temperature is achieved. There are two types of thermostat:

Wax Pellet Thermostats

Utilises a wax pellet (power pill) to enable the operation of the primary valve once the nominated thermostat temperature has been achieved.

Electronically Controlled Thermostats

Enables electronic operation of the control valve, delivering more accurate and immediate temperature control. Current applications are limited to high end European vehicles.

The thermostat does not create heat within a vehicle cooling system; the thermostat reacts to changes in temperature caused by internal combustion and responds to these changes in temperature by opening and closing the primary valve.

High Flow Thermostats



High flow thermostats improve cooling system performance and are designed to interchange with the original thermostat. They are manufactured with a larger primary valve enabling up to 30% more coolant flow. High flow thermostats provide:

- Increased cooling system efficiency
- Even temperature control
- Improved fuel economy
- Reduced engine wear



They are ideal for high performance applications or where additional load is placed on the engine (e.g. towing).

High flow thermostats should not be used to mask alternate cooling system faults, always ensure that the entire cooling system is in good working order as part of thermostat installation.

Quality

Tridon thermostats are manufactured from high quality stainless steel and copper to resist the corrosive effect of engine coolant. They meet or exceed OEM standards and are 100% tested and calibrated for opening temperature and maximum opening temperature during the manufacturing process.

Thermostats

Thermostat Styles

Two main types of thermostat design are commonly used including **Conventional Thermostats** and **Bypass Thermostats** (Dual Valve or Reverse Poppet). Both can be individual units or incorporated in specially designed thermostat housing assemblies.

Conventional Thermostats

Conventional thermostats operate utilising a single primary valve. During operation the primary valve opens allowing coolant to flow to the radiator once the predetermined temperature of the thermostat has been achieved. More commonly used in early vehicle applications, conventional thermostats are still widely used in modern cooling systems.

Bypass Thermostats

Bypass thermostats operate utilising a main primary valve along with a secondary valve located at the foot of the thermostat assembly. The primary valve operates as per conventional (non-bypass) design. The secondary valve is utilised during engine warm up, allowing coolant to be circulated through the engine. Bypass style thermostat design enables the temperature of the engine to rise more evenly, minimising hot and cold spots within the engine.

Thermostat Selection

The Tridon thermostat range has been developed to operate within original equipment manufacturer's specifications. As the thermostat must be compatible with the vehicle cooling system, always refer to the vehicle application list to ensure the correct part number is selected. Failure to use the correct thermostat may result in severe engine damage.

Always check the following prior to installing a new thermostat:

- Thermostat style (Non-Bypass or Bypass)
- Thermostat dimensions
- Correct operating temperature

Additional vehicles and applications may have been introduced after the time of catalogue printing. For complete, up to date vehicle application listings refer to the Tridon website www.tridon.com.au (or www.tridon.co.nz) and go to Tridon Part Finder.



Thermostat Installation

Conventional Thermostat Application - Correct

Figure 1 shows the installation of the correct conventional style thermostat. When the engine is cold the primary valve is closed preventing the flow of coolant to the radiator. As the engine reaches the predetermined temperature the primary valve opens. Full coolant flow is directed through the primary valve towards the radiator.

Conventional Thermostat Application - Incorrect

Figure 2 shows the installation of an incorrect bypass thermostat in a conventional (non-bypass) application.

When the engine is cold the primary valve is closed preventing the flow of coolant to the radiator. As the engine reaches the predetermined temperature the primary valve **cannot** open due to the restriction of the secondary valve by the design of the assembly. As a result coolant cannot circulate through the engine cooling system, **significant engine damage may result as part of this incorrect installation.**

Bypass Thermostat Application - Correct

Figure 3 shows the installation of the correct bypass style thermostat.

When the engine is cold the primary valve is closed preventing the flow of coolant to the radiator. The secondary valve is open directing the flow of coolant back through the engine bypass valve allowing the engine temperature to rise quickly. As the engine reaches the predetermined temperature the primary valve opens and the secondary valve closes over the bypass valve.

Figure 4 shows the primary valve in the fully open position and the secondary valve blocking the engine bypass valve inside the assembly. Full coolant flow is directed through the primary valve towards the radiator.

Bypass Thermostat Application - Incorrect

Figure 5 shows the installation of an incorrect bypass thermostat in a bypass application. The primary valve is in the fully open position; the secondary valve is **not** blocking the engine bypass valve inside the assembly.

Only partial flow of coolant is directed towards the radiator, the remaining hot coolant continues to circulate through the system via the engine bypass valve. As a result the cooling efficiency system is reduced leading to higher engine temperatures and potential premature failure of other components within the cooling system.

Bypass Thermostat Application - Incorrect

Figure 6 shows the installation of an incorrect conventional (non-bypass) thermostat in a bypass application.

The conventional thermostat without a foot valve allows unrestricted flow of the hot coolant through the system via the engine bypass valve whilst primary valve is in the full open position. As a result the cooling efficiency system is greatly reduced leading to much higher engine temperatures and potential premature failure of other components within the cooling system.

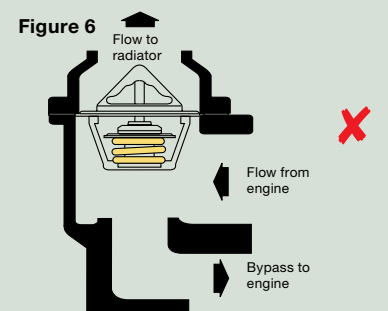
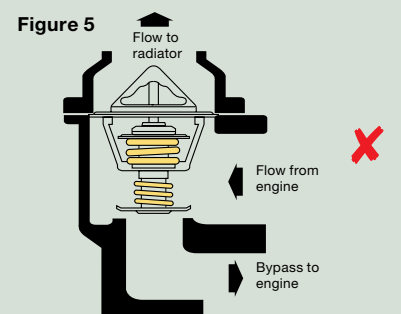
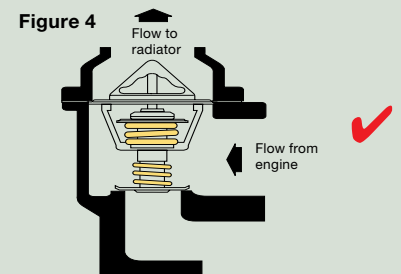
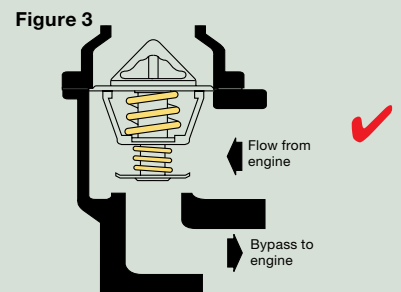
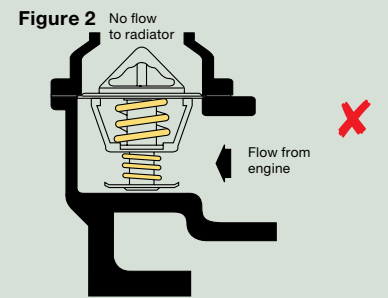
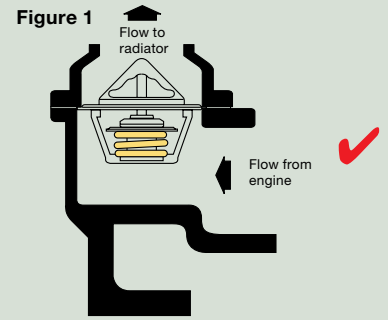

Thermostats

Thermostat Temperature

The thermostat operating temperature is predetermined; in wax style thermostats the predetermined temperature is governed by the properties of the wax pellets used.

The fully open temperature of the thermostat is designated by the maximum travel point of the primary valve. The maximum opening temperature may vary depending on the thermostat design; usually the maximum opening temperature of the thermostat is 10°C to 14°C above the crack point. Thermostats are available in various predetermined temperatures, most commonly with opening temperatures of between 70°C to 100°C.

The thermostat is an integral part of modern engine operation, it is crucial that the correct engine temperature be achieved quickly and maintained in order for the engine management system to operate as required.

Modern engines with complex engine management systems run at higher temperatures than earlier less complex designs. Higher engine temperatures (higher thermostat temperatures) enable increases in engine power output, along with decreases in fuel consumption and exhaust emissions.

Jiggle Pin

A jiggle pin or pressure relief hole is incorporated in some thermostat designs. The function of a jiggle pin or pressure relief hole is used to disperse air build up from behind the primary valve of the closed thermostat.

Air build up can lead to problems with heat transfer of the coolant to the wax pellet and alter or delay the desired opening temperature of the thermostat.



Frequently Asked Questions

Q) Why does the engine run hotter with the new thermostat than the old one?

- Incorrect thermostat selection and installation. Refer to application list for correct applications.
- Incorrect fault diagnosis. Faults should be diagnosed and repairs carried out by a trained professional in accordance with the manufacturers' specification.
- Incorrect coolant mix or specification may result in changes in coolant boiling point and engine temperature.
- Air pockets within the cooling system may affect thermostat opening temperature.

Q) How long should a thermostat last?

- Dependant on cooling system condition. Poor cooling system condition (corrosion/calcium build up) may reduce thermostat service life.
- General replacement time is 3-5 years (dependant on cooling system service history).
- Tridon thermostats are tested to 100,000 cycles.

Q) How far should the thermostat open?

- Directly related to diameter of the primary valve and thermostat opening temperature.
Maximum opening point = $\frac{1}{4}$ x primary valve diameter.
Maximum opening point = 10°C - 14°C above opening temperature.

Q) Why does the thermostat not open when I test it?

- Poor testing procedure. See correct testing procedure (page 92-93)
- High thermostat opening temperature - 90°C and above require higher testing temperatures
- Heat loss - incorrect testing procedure (pouring boiling water onto cold thermostat) will result in a thermostat testing failure.

Q) I have recently replaced a thermostat to overcome an overheating problem and the vehicle is still overheating?

- Alternate cooling system component failure -
 1. Radiator Cap
 2. Fan Switch
 3. Fan / Water Pump Belt Tension or Condition
 4. Coolant Level / Coolant Mix
 5. Hose Leakage
 6. Water Pump
 7. Radiator Blockage
 8. Radiator Condition
 9. Air Pockets in Cooling System

Thermostats

Thermostat Testing Procedure

A thermostat should be tested as detailed below. For accurate and valid results the tests should be performed under carefully controlled conditions.

1. Inspect the thermostat for signs of damage, corrosion or heat stress. Replace the thermostat if these conditions are present.
2. To test the operation of the thermostat, fill the test container with 50% water and 50% coolant concentrate (minimum 2 litres).
3. Open the thermostat and insert a fine thread under the primary valve.
4. Suspend the thermostat by the thread in the container. The thermostat must be fully submerged and not touch any part of the container.
5. Place a thermometer into the coolant so that the bulb is adjacent to the thermostat wax pellet (power pill).
6. Heat the coolant slowly from cold to activate the wax pellet correctly. Agitate the coolant mix for accurate results.
7. Observe the thermometer and note the temperature as the thermostat drops from the thread. This reading indicates the opening temperature of the thermostat.
8. The temperature should be increased and the thermostat observed to ensure that it fully opens. The thermostat should be fully open at a temperature approximately 12°C (22°F) above the specified opening temperature. For example a thermostat with an opening temperature of 82°C should be fully open at 82°C + 12°C = 94°C
9. Travel distance to achieve the fully open temperature is $\frac{1}{4}$ of the primary valve diameter. For example, primary valve diameter 24mm \div 4 = 6mm. 6mm travel is the fully open extended position.

NOTE: There is a tolerance of 2.5°C plus or minus of the nominated temperature rating, the thermostat should be replaced if it opens at a temperature more than 6°C (11°F) below or 3°C (5°F) above the specified opening temperature.

Testing needs to be conducted with the coolant heated at a slow, steady rate and with the thermostat being placed into the water at room temperature. This allows the thermostat to heat up evenly to the operating temperature, and simulate normal vehicle thermostat operation.

If the coolant is allowed to heat too quickly it may begin to boil, bubbles may form around thermostat and not allow correct heat transfer to the power pill. This may lead to inaccurate test results.

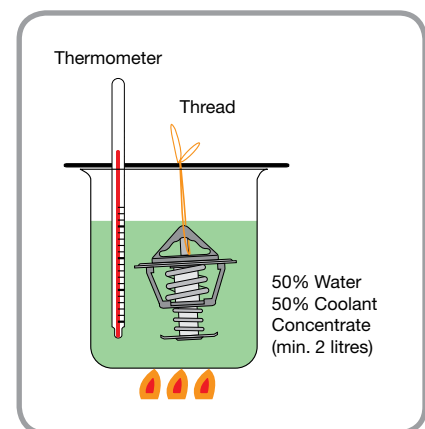

When cool, carefully examine the thermostat valve to ensure it has returned to the closed position (valve seated). If it does not seat correctly, the thermostat should be replaced.

If the correct thermostat operational specifications are not achieved during the first test repeat the test procedure. In some cases a used thermostat may require several operational cycles to enable correct operation. This may occur in cases where the thermostat has been exposed to high temperatures, dirty cooling systems or left for a period of time between vehicle operation and testing.

Incorrect Thermostat Testing Procedure

If these test procedures are not followed, the thermostat testing cannot be guaranteed and may lead to inaccurate test results.

Common incorrect thermostat tests include:

- Pouring boiling water on the thermostat and it not opening!
- Dropping the thermostat into boiling water.
- Placing the thermostat in a microwave to heat the coolant (water)!

Thermostat Calibration

All Tridon thermostats are individually calibrated during the manufacturing process to ensure 100% operation prior to sale.

Each Tridon thermostat is stamped with the rated temperature. This rated temperature is the commencement or opening temperature of the thermostat, the fully open temperature is between 10°C - 14°C above the opening temperature.

TT1 Series

Conventional style thermostat with jiggle pin.

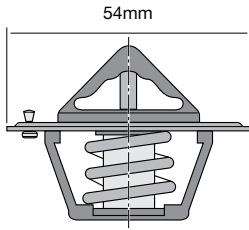

| Temp. | Part No. | Temp. | Part No. |
|-------|----------|-------|----------|
| 71°C | TT1-160 | 82°C | TT1-180 |
| 75°C | TT1-167 | 88°C | TT1-190 |
| 77°C | TT1-170 | 89°C | TT1-192 |
| 79°C | TT1-174 | 91°C | TT1-195 |

TT2 Series

Conventional style thermostat.

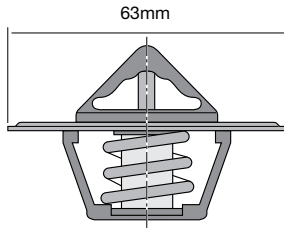

| Temp. | Part No. |
|-------|----------|
| 71°C | TT2-160 |
| 77°C | TT2-170 |
| 82°C | TT2-180 |
| 91°C | TT2-195 |

TT4 Series

Conventional style thermostat.

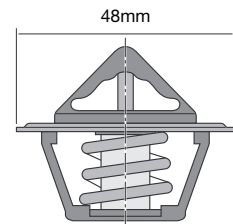

| Temp. | Part No. | Temp. | Part No. |
|-------|----------|-------|----------|
| 82°C | TT4-180 | 92°C | TT4-198 |
| 85°C | TT4-185 | | |
| 89°C | TT4-192 | | |
| 91°C | TT4-195 | | |

TT6 Series

Conventional style thermostat.

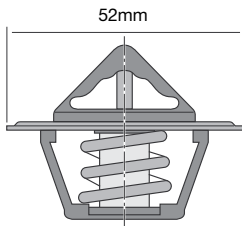

| Temp. | Part No. |
|-------|----------|
| 71°C | TT6-160 |
| 82°C | TT6-180 |
| 88°C | TT6-190 |

TT203 Series

Conventional style thermostat.

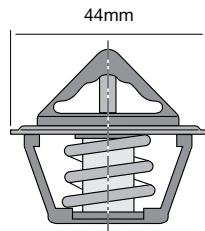

| Temp. | Part No. |
|-------|-----------|
| 82°C | TT203-180 |
| 91°C | TT203-195 |

TT204 Series

Conventional style thermostat.

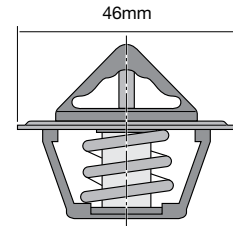

| Temp. | Part No. |
|-------|-----------|
| 79°C | TT204-174 |

TT207 Series

Special design, gasket included.

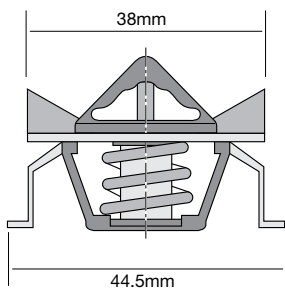

| Temp. | Part No. |
|-------|-----------|
| 89°C | TT207-192 |

TT208 Series

Conventional style thermostat.

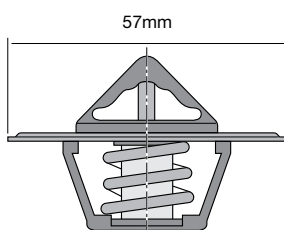

| Temp. | Part No. |
|-------|-----------|
| 77°C | TT208-170 |
| 82°C | TT208-180 |

TT209 Series

Conventional style thermostat with jiggle pin.

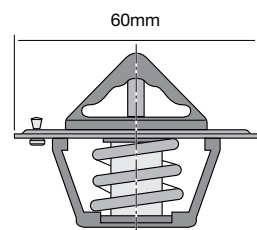

| Temp. | Part No. |
|-------|-----------|
| 71°C | TT209-160 |

TT214 Series

Bypass style thermostat with jiggle pin.

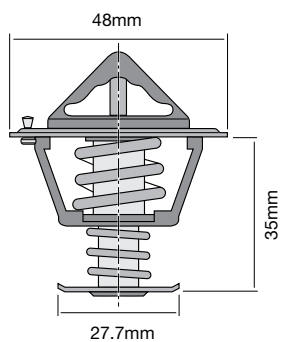

| Temp. | Part No. | Temp. | Part No. |
|-------|-----------|-------|-----------|
| 60°C | TT214-140 | 89°C | TT214-192 |
| 71°C | TT214-160 | | |
| 77°C | TT214-170 | | |
| 82°C | TT214-180 | | |

TT215 Series

Bypass style thermostat.

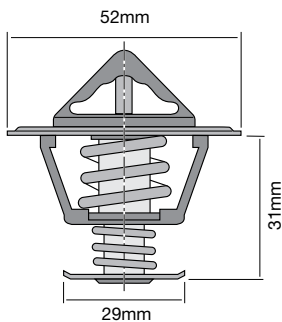

| Temp. | Part No. |
|-------|-----------|
| 82°C | TT215-180 |

TT216 Series

Bypass style thermostat.

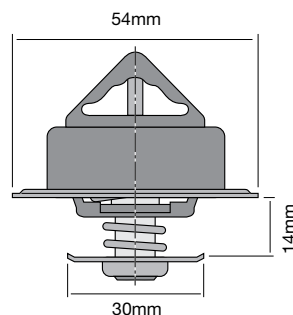

| Temp. | Part No. |
|-------|------------|
| 82°C | TT216-180P |
| 89°C | TT216-192P |

TT218 Series

Special design, gasket included.

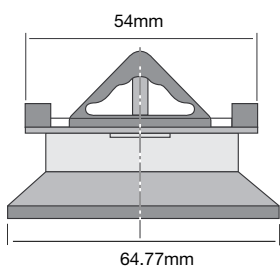

| Temp. | Part No. |
|-------|------------|
| 71°C | TT218-160P |
| 82°C | TT218-180P |

TT219 Series

Bypass style thermostat with jiggle pin.

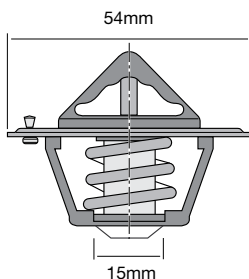

| Temp. | Part No. |
|-------|-----------|
| 71°C | TT219-160 |
| 82°C | TT219-180 |

TT220 Series

Bypass style thermostat.

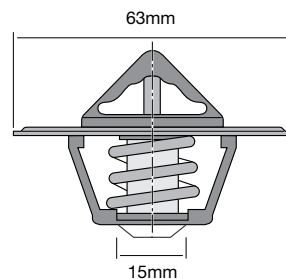

| Temp. | Part No. |
|-------|-----------|
| 71°C | TT220-160 |
| 82°C | TT220-180 |

TT221 Series

Bypass style thermostat.

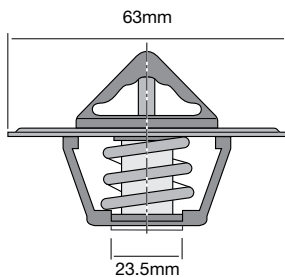

| Temp. | Part No. |
|-------|-----------|
| 71°C | TT221-160 |
| 77°C | TT221-170 |
| 82°C | TT221-180 |

TT222 Series

Bypass style thermostat.

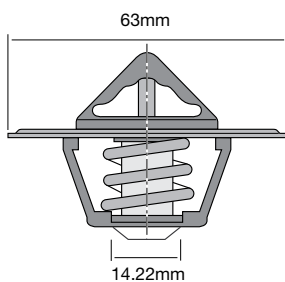

| Temp. | Part No. |
|-------|-----------|
| 71°C | TT222-160 |
| 82°C | TT222-180 |

TT224 Series

Bypass style thermostat.

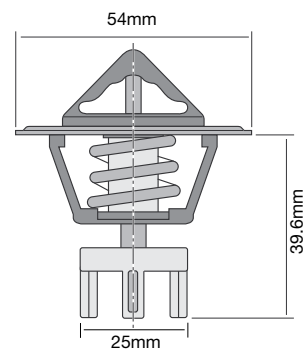

| Temp. | Part No. |
|-------|-----------|
| 82°C | TT224-180 |
| 91°C | TT224-195 |

TT225 Series

Bypass style thermostat.

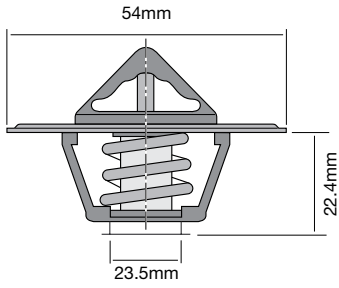

Temp. Part No.
 71°C TT225-160
 82°C TT225-180
 91°C TT225-195

TT226 Series

Bypass style thermostat.

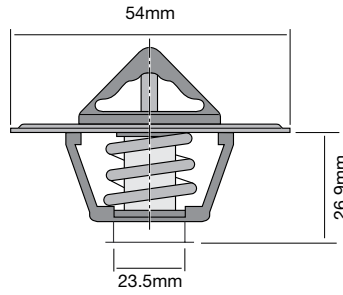

Temp. Part No.
 71°C TT226-160
 82°C TT226-180
 91°C TT226-195

TT228 Series

Bypass style thermostat with jiggle pin.

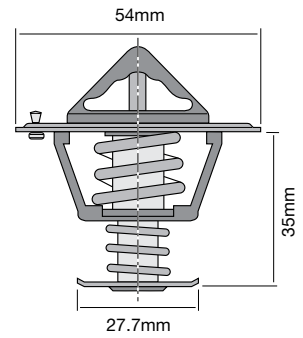

Temp. Part No.
 71°C TT228-160
 77°C TT228-170
 82°C TT228-180
 91°C TT228-195

TT229 Series

Bypass style thermostat.

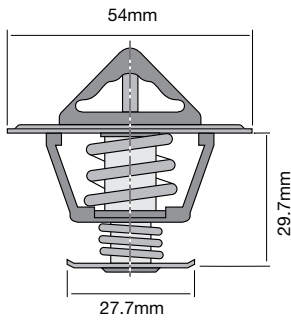

Temp. Part No.
 77°C TT229-170
 82°C TT229-180
 91°C TT229-195

TT230 Series

Bypass style thermostat with jiggle pin.

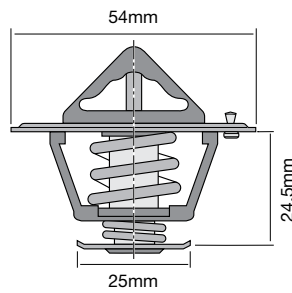

Temp. Part No. Temp. Part No.
 75°C TT230-167 89°C TT230-192
 77°C TT230-170
 79°C TT230-174
 82°C TT230-180

TT231 Series

Bypass style thermostat with jiggle pin.

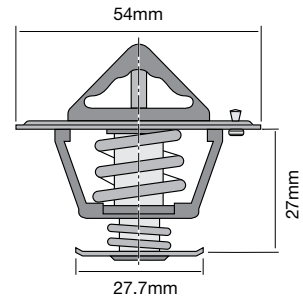

Temp. Part No.
 75°C TT231-167
 82°C TT231-180
 89°C TT231-192

TT233 Series

Bypass style thermostat with jiggle pin.

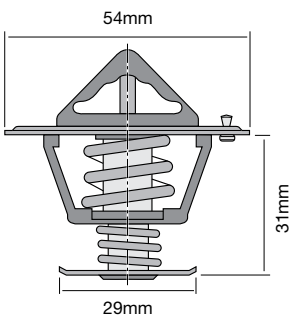

Temp. Part No. Temp. Part No.
 71°C TT233-160 91°C TT233-195
 77°C TT233-170
 82°C TT233-180
 89°C TT233-192

TT234 Series

Bypass style thermostat with jiggle pin.

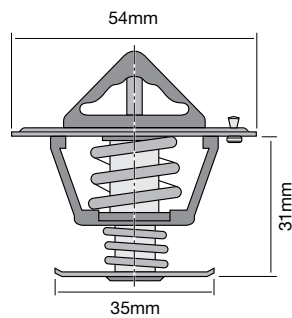

Temp. Part No.
 71°C TT234-160
 82°C TT234-180
 89°C TT234-192
 91°C TT234-195

TT235 Series

Bypass style thermostat.

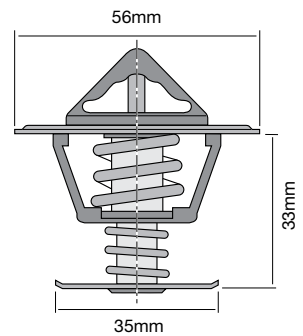

Temp. Part No.
 75°C TT235-167
 82°C TT235-180
 91°C TT235-195

TT237 Series

Special design.

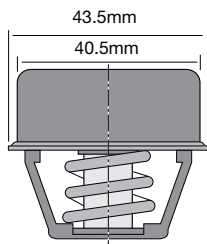

Temp. Part No.
 77°C TT237-170P
 82°C TT237-180P
 89°C TT237-192P

TT238 Series

Special design.

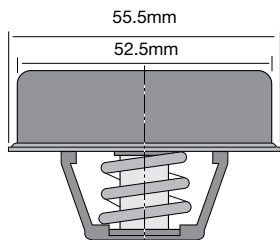

Temp. Part No.
 71°C TT238-160
 77°C TT238-170
 82°C TT238-180

TT239 Series

Offset conventional style thermostat with jiggle pin.

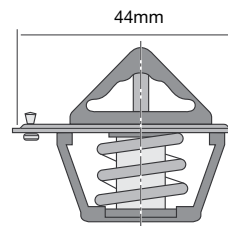

Temp. Part No.
 82°C TT239-180
 85°C TT239-185
 89°C TT239-192

TT240 Series

Offset conventional style thermostat with jiggle pin.

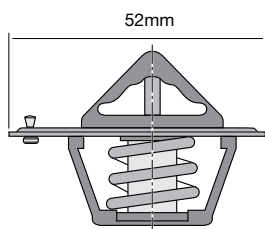

Temp. Part No.
 71°C TT240-160
 82°C TT240-180
 89°C TT240-192

TT241 Series

Offset conventional style thermostat with jiggle pin.

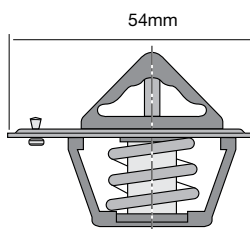

Temp. Part No.
 77°C TT241-170
 82°C TT241-180
 85°C TT241-185
 88°C TT241-190

TT242 Series

Offset bypass style thermostat with jiggle pin.

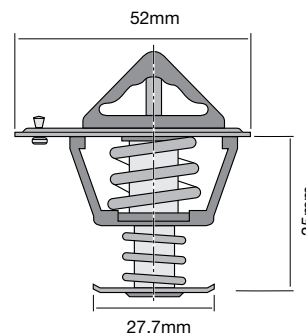

Temp. Part No.
 77°C TT242-170
 82°C TT242-180
 89°C TT242-192

TT244 Series

Conventional style thermostat with jiggle pin.

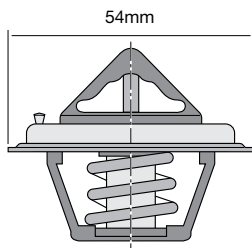

Temp. Part No.
 82°C TT244-180
 89°C TT244-192
 91°C TT244-195
 92°C TT244-198

TT245 Series

Special design thermostat with pressure relief hole, gasket included.

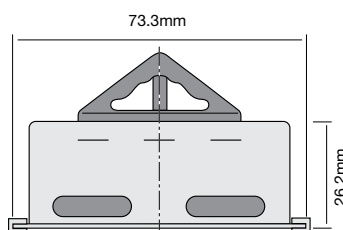

Temp. Part No.
 71°C TT245-160P
 82°C TT245-180P
 89°C TT245-192P

TT246 Series

Bypass style thermostat.

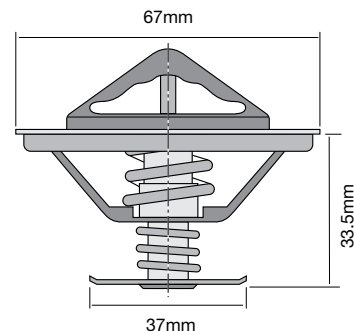

Temp. Part No.
 82°C TT246-180

TT247 Series

Bypass style thermostat with jiggle pin.

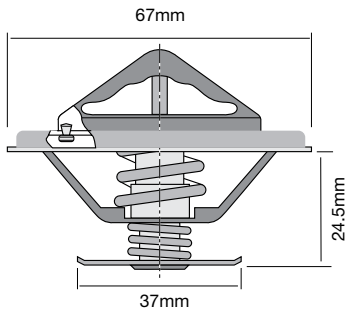

| Temp. | Part No. | Temp. | Part No. |
|-------|-----------|-------|-----------|
| 77°C | TT247-170 | 91°C | TT247-195 |
| 79°C | TT247-174 | | |
| 82°C | TT247-180 | | |
| 89°C | TT247-192 | | |

TT248 Series

Bypass style thermostat with jiggle pin.

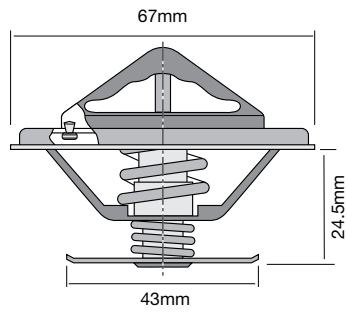

| Temp. | Part No. | Temp. | Part No. |
|-------|-----------|-------|-----------|
| 71°C | TT248-160 | 82°C | TT248-180 |
| 75°C | TT248-167 | 87°C | TT248-189 |
| 77°C | TT248-170 | 89°C | TT248-192 |
| 79°C | TT248-174 | 91°C | TT248-195 |

TT249 Series

Bypass style thermostat.

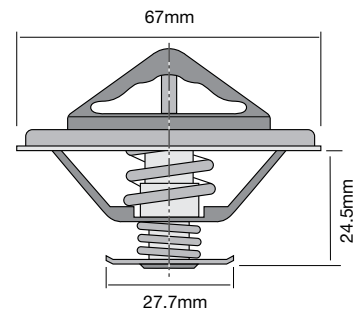

| Temp. | Part No. |
|-------|-----------|
| 77°C | TT249-170 |
| 79°C | TT249-174 |
| 82°C | TT249-180 |

TT251 Series

Bypass style thermostat with jiggle pin.

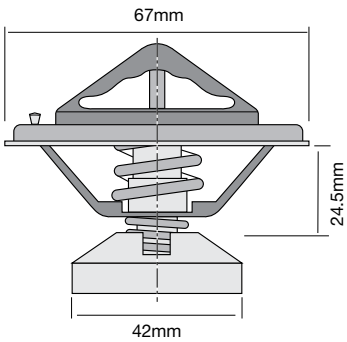

| Temp. | Part No. |
|-------|-----------|
| 82°C | TT251-180 |
| 85°C | TT251-185 |

TT255 Series

Special design bypass style thermostat integrated into housing, gasket included.

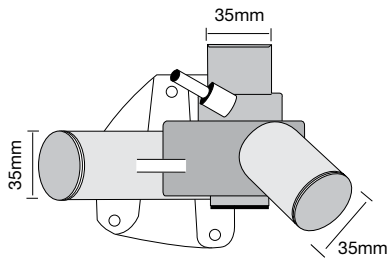

| Temp. | Part No. |
|-------|------------|
| 82°C | TT255-180P |

TT256 Series

Special design thermostat integrated into housing.

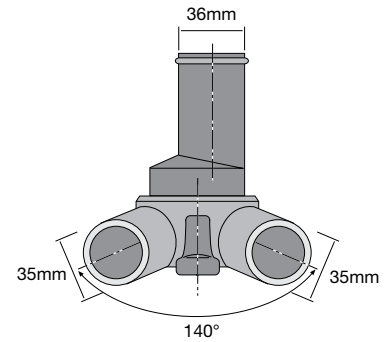

| Temp. | Part No. |
|-------|------------|
| 82°C | TT256-180P |

TT258 Series

Special design bypass style thermostat integrated into housing.

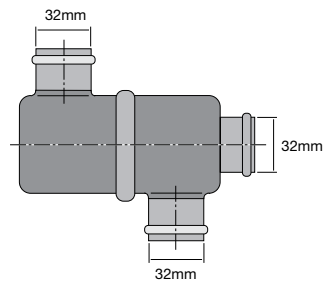

| Temp. | Part No. |
|-------|------------|
| 82°C | TT258-180P |

TT259 Series

Special design bypass style thermostat integrated into housing.

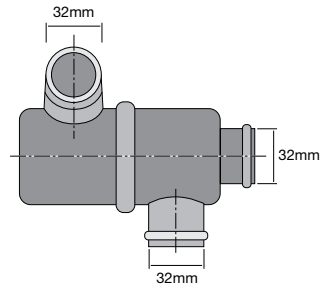

| Temp. | Part No. |
|-------|------------|
| 83°C | TT259-181P |
| 91°C | TT259-195P |

TT260 Series

Special design bypass style thermostat integrated into housing.

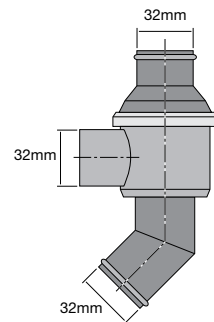

| Temp. | Part No. |
|-------|------------|
| 82°C | TT260-180P |

TT261 Series

Conventional style thermostat integrated into housing, 3 bolt holes.

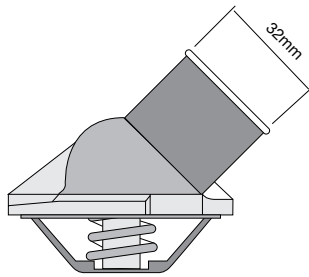

Temp. Part No.
88°C TT261-190P

TT262 Series

Special design bypass style thermostat integrated into housing.

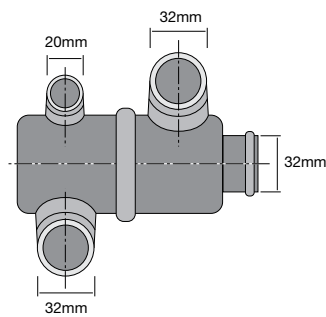

Temp. Part No.
82°C TT262-180P

TT263 Series

Bypass style thermostat with jiggle pin.

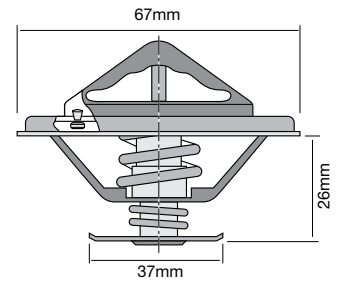

Temp. Part No.
79°C TT263-174

TT265 Series

Bypass style thermostat with jiggle pin.

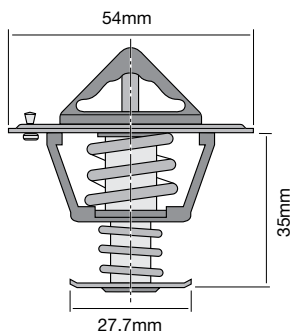

Temp. Part No.
82°C TT265-180
89°C TT265-192
91°C TT265-195

TT266 Series

Bypass style thermostat.

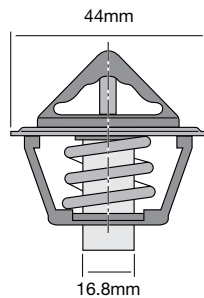

Temp. Part No.
82°C TT266-180

TT268 Series

Bypass style thermostat with inverse jiggle pin.

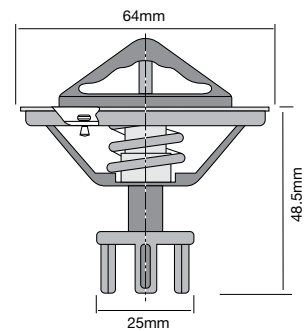

Temp. Part No.
71°C TT268-160
77°C TT268-170
82°C TT268-180

TT269 Series

Bypass style thermostat with jiggle pin.

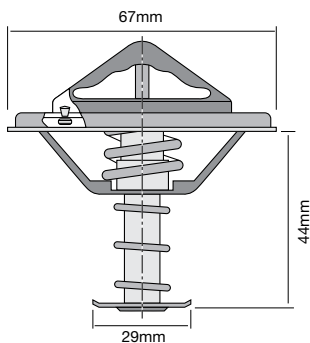

Temp. Part No.
80°C TT269-176
82°C TT269-180

TT270 Series

Bypass style thermostat with jiggle pin.

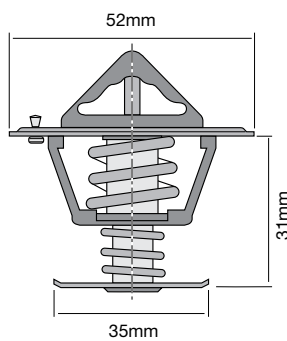

Temp. Part No.
89°C TT270-192

TT271 Series

Conventional style thermostat.

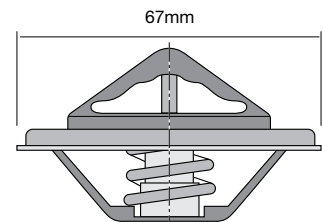

Temp. Part No.
82°C TT271-180

TT272 Series

Bypass style thermostat with jiggle pin.

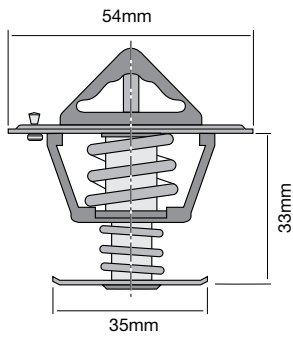

Temp. Part No.
 77°C TT272-170
 82°C TT272-180
 89°C TT272-192
 91°C TT272-195

TT273 Series

Bypass style thermostat.

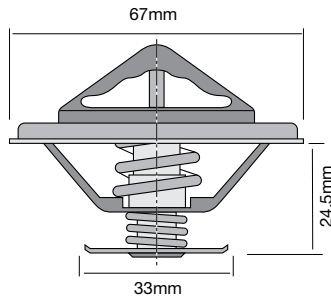

Temp. Part No.
 77°C TT273-170
 82°C TT273-180
 89°C TT273-192

TT274 Series

Bypass style thermostat with jiggle pin.

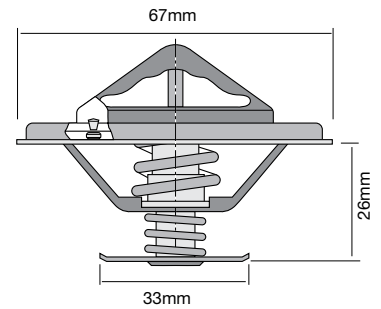

Temp. Part No.
 82°C TT274-180
 89°C TT274-192
 92°C TT274-198

TT275 Series

Bypass style thermostat.

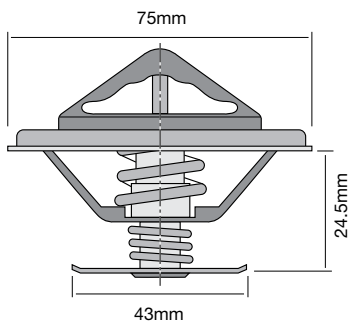

Temp. Part No.
 71°C TT275-160
 79°C TT275-174
 85°C TT275-185

TT276 Series

Conventional style thermostat.

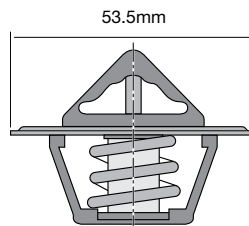

Temp. Part No.
 82°C TT276-180
 89°C TT276-192

TT277 Series

Bypass style thermostat.

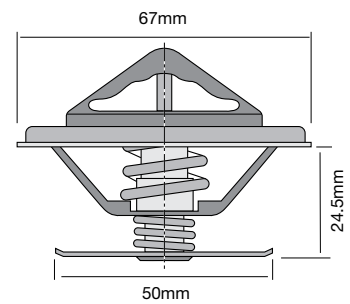

Temp. Part No.
 82°C TT277-180
 89°C TT277-192

TT278 Series

Bypass style thermostat with jiggle pin.

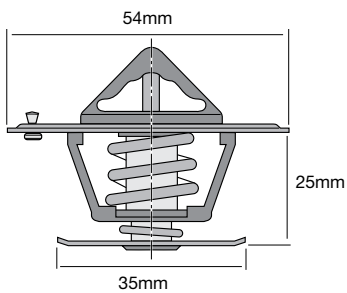

Temp. Part No.
 82°C TT278-180

TT281 Series

Bypass style thermostat with inverse jiggle pin.

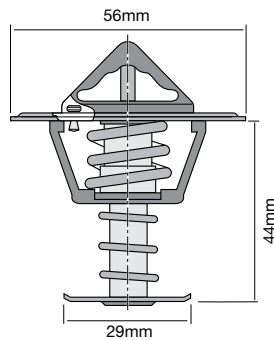

Temp. Part No.
 77°C TT281-170
 82°C TT281-180

TT282 Series

Bypass style thermostat.

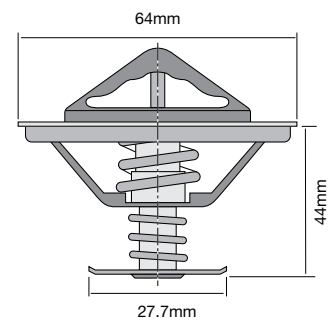

Temp. Part No.
 77°C TT282-170

TT283 Series

Bypass style thermostat integrated into housing, 3 bolt holes, gasket included.

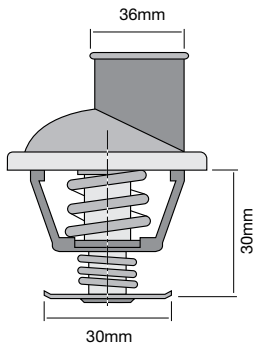

Temp. Part No.
91°C TT283-195P

TT286 Series

Bypass style thermostat with jiggle pin.

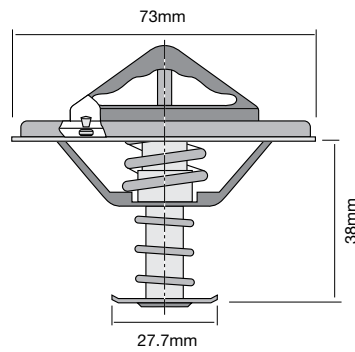

Temp. Part No.
77°C TT286-170P
82°C TT286-180P
89°C TT286-192P

TT287 Series

Bypass style thermostat integrated into housing, 3 bolt holes, gasket included.

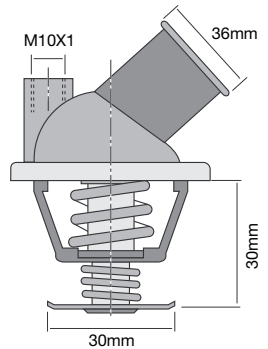

Temp. Part No.
82°C TT287-180P
91°C TT287-195P

TT288 Series

Bypass style thermostat with inverse jiggle pin.

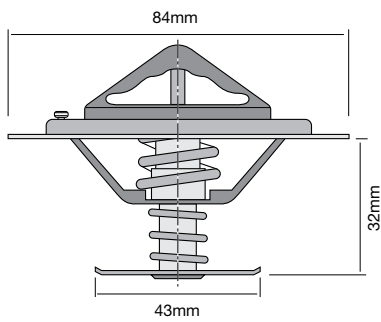

Temp. Part No.
79°C TT288-174
85°C TT288-185
91°C TT288-195
95°C TT288-203

TT289 Series

Bypass style thermostat.

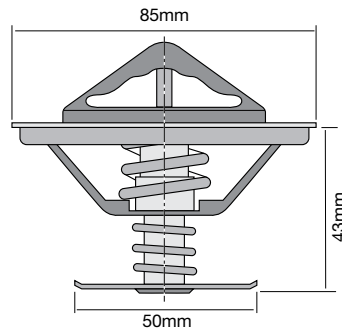

Temp. Part No.
71°C TT289-160P
79°C TT289-174P
82°C TT289-180P

TT292 Series

Bypass style thermostat.

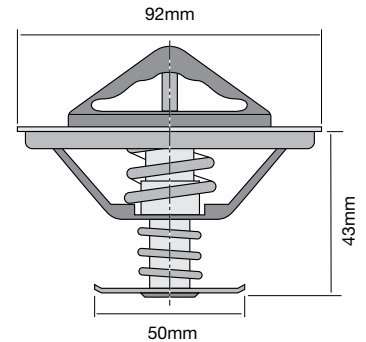

Temp. Part No.
71°C TT292-160P
75°C TT292-167P
79°C TT292-174P

TT293 Series

Bypass style thermostat.

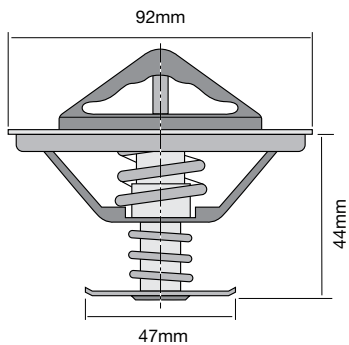

Temp. Part No.
71°C TT293-160P
75°C TT293-167P
79°C TT293-174P

TT294 Series

Offset conventional style thermostat with jiggle pin.

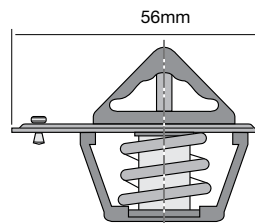

Temp. Part No.
77°C TT294-170
84°C TT294-183
88°C TT294-190

TT296 Series

Bypass style thermostat with jiggle pin.

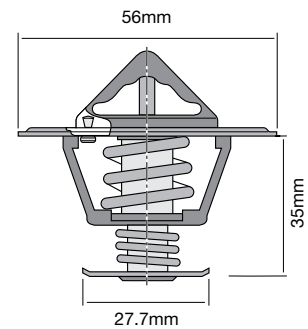

Temp. Part No.
82°C TT296-180

TT297 Series

Bypass style thermostat with inverse jiggle pin.

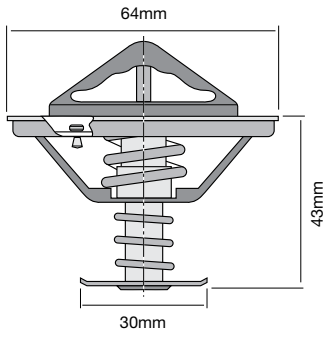

Temp. Part No.
82°C TT297-180
89°C TT297-192

TT298 Series

Bypass style thermostat with inverse jiggle pin.

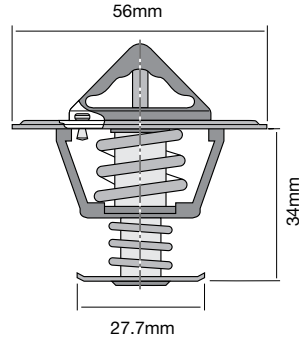

Temp. Part No.
82°C TT298-180

TT299 Series

Bypass style thermostat with inverse jiggle pin, gasket included.

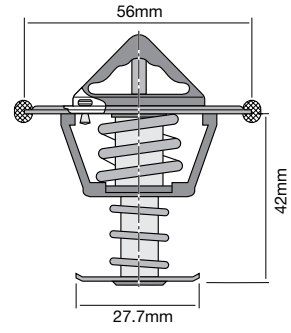

Temp. Part No.
71°C TT299-160
77°C TT299-170
82°C TT299-180
89°C TT299-192

TT301 Series

Bypass style thermostat with inverse jiggle pin, gasket included.

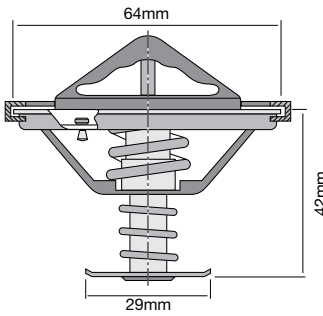

Temp. Part No.
77°C TT301-170
82°C TT301-180
85°C TT301-185
89°C TT301-192

TT302 Series

Bypass style thermostat with inverse jiggle pin.

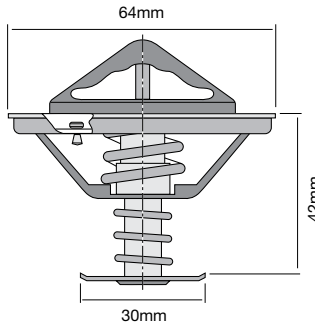

Temp. Part No.
77°C TT302-170
82°C TT302-180

TT303 Series

Bypass style thermostat with inverse jiggle pin, gasket included.

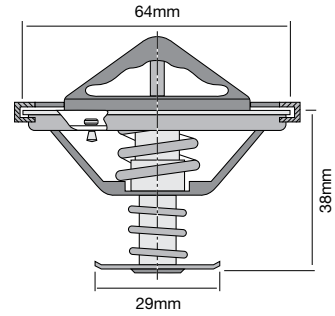

Temp. Part No.
82°C TT303-180

TT304 Series

Bypass style thermostat with inverse jiggle pin.

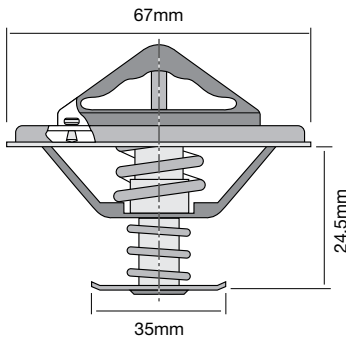

Temp. Part No.
77°C TT304-170
82°C TT304-180
84°C TT304-183
89°C TT304-192

TT305 Series

Conventional style thermostat.

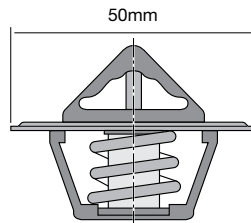

Temp. Part No.
75°C TT305-167
89°C TT305-192

TT307 Series

Bypass style thermostat with jiggle pin, gasket included.

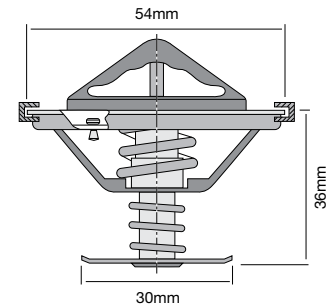

Temp. Part No.
82°C TT307-180

TT319 Series

Bypass style thermostat with inverse jiggle pin.

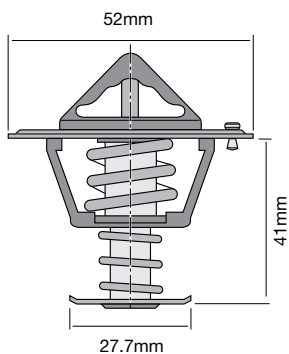

Temp. Part No.
82°C TT319-180

TT320 Series

Conventional style thermostat with inverse jiggle pin.

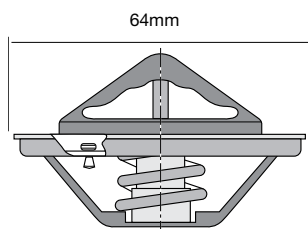

Temp. Part No.
77°C TT320-170
82°C TT320-180

TT322 Series

Bypass style thermostat with jiggle pin.

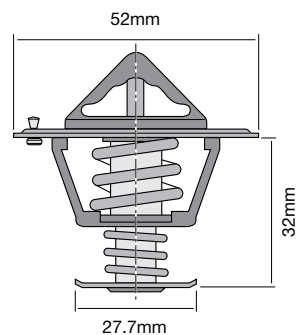

Temp. Part No.
82°C TT322-180
89°C TT322-192

TT323 Series

Offset conventional style thermostat with double jiggle pins.

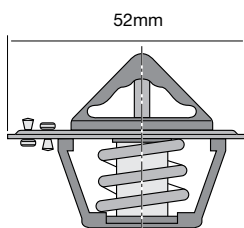

Temp. Part No.
82°C TT323-180
89°C TT323-192

TT326 Series

Bypass style thermostat with jiggle pin.

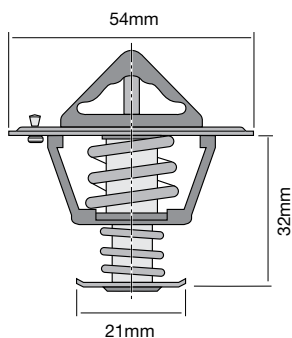

Temp. Part No.
82°C TT326-180

TT327 Series

Offset bypass style thermostat with jiggle pin.

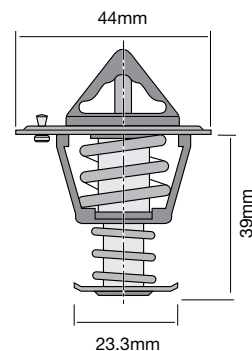

Temp. Part No.
82°C TT327-180

TT328 Series

Bypass style thermostat with jiggle pin.

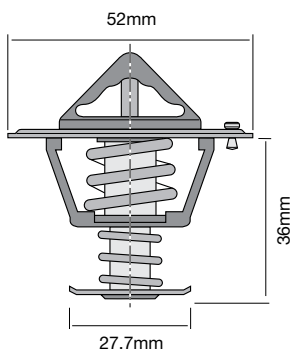

Temp. Part No.
77°C TT328-170
82°C TT328-180

TT329 Series

Bypass style thermostat with jiggle pin.

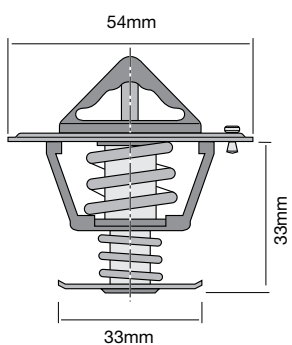

Temp. Part No.
77°C TT329-170
82°C TT329-180
89°C TT329-192

TT330 Series

Bypass style thermostat.

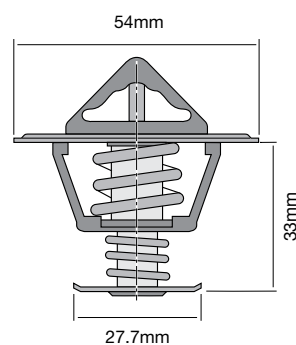

Temp. Part No.
77°C TT330-170
82°C TT330-180

TT331 Series

Bypass style thermostat with jiggle pin.

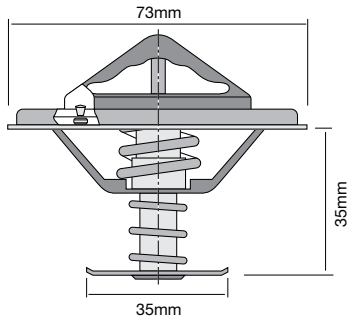

Temp. Part No.
77°C TT331-170
82°C TT331-180

TT332 Series

Bypass style thermostat with jiggle pin.

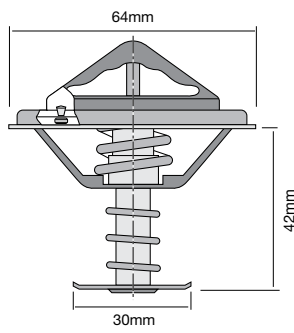

Temp. Part No.
82°C TT332-180
91°C TT332-195

TT333 Series

Conventional style thermostat with jiggle pin, gasket included.

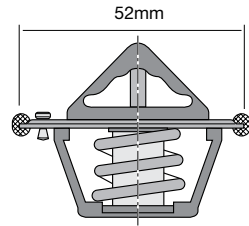

Temp. Part No.
92°C TT333-198

TT334 Series

Bypass style thermostat with inverse jiggle pin.

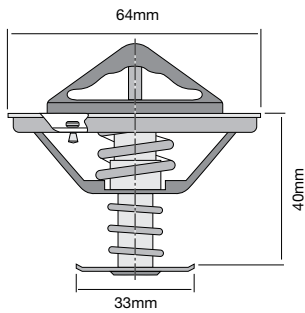

Temp. Part No.
77°C TT334-170
82°C TT334-180

TT335 Series

Bypass style thermostat with jiggle pin.

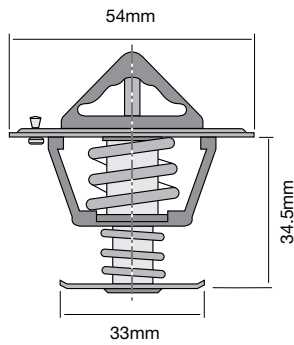

Temp. Part No.
82°C TT335-180
89°C TT335-192

TT336 Series

Bypass style thermostat with jiggle pin.

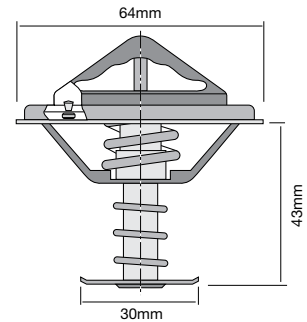

Temp. Part No.
82°C TT336-180

TT338 Series

Bypass style thermostat with jiggle pin.

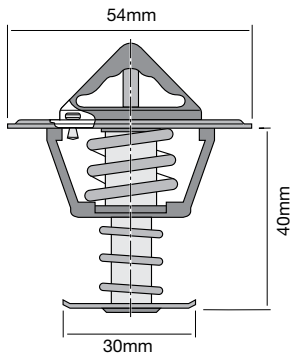

Temp. Part No.
91°C TT338-195

TT340 Series

Offset conventional style thermostat with jiggle pin, gasket included.

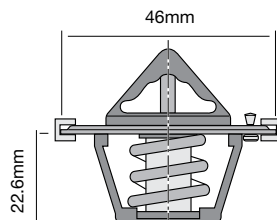

Temp. Part No.
82°C TT340-180
91°C TT340-195

TT342 Series

Bypass style thermostat.

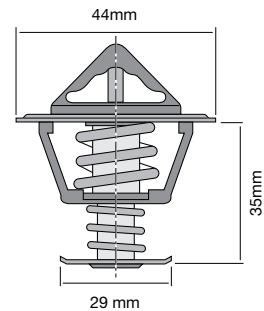

Temp. Part No.
74°C TT342-165
77°C TT342-170
82°C TT342-180

TT343 Series

Bypass style thermostat integrated into housing with jiggle pin, 3 bolt holes, gasket included.

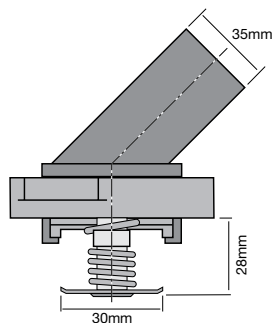

Temp. Part No.
82°C TT343-180P

TT345 Series

Special design thermostat.

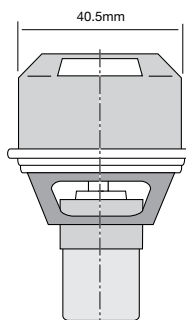

Temp. Part No.
89°C TT345-192P

TT347 Series

Special design thermostat integrated into housing, 3 bolt holes, gasket included.

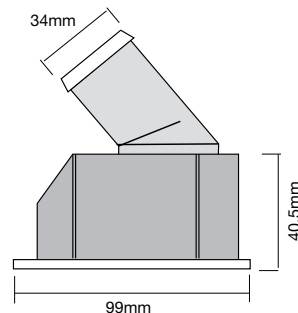

Temp. Part No.
89°C TT347-192P
92°C TT347-198P

TT348 Series

Bypass style thermostat integrated into housing with jiggle pin, 3 bolt holes, gasket included.

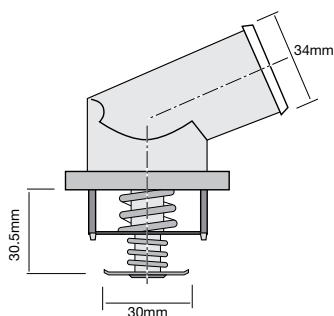

Temp. Part No.
92°C TT348-198P

TT349 Series

Bypass style thermostat integrated into housing, 2 bolt holes, gasket included.

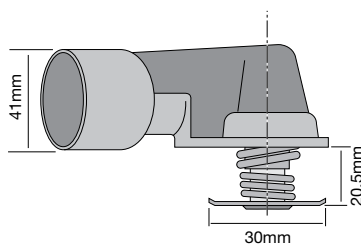

Temp. Part No.
89°C TT349-192P
92°C TT349-198P

TT350 Series

Special design thermostat integrated into housing, 2 bolt holes & water outlet, gasket included.

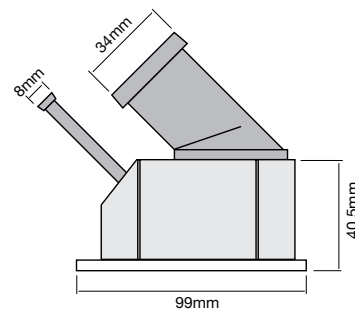

Temp. Part No.
82°C TT350-180P
89°C TT350-192P
92°C TT350-198P

TT351 Series

Bypass design thermostat integrated into housing & water outlet, 3 bolt holes, gasket included.

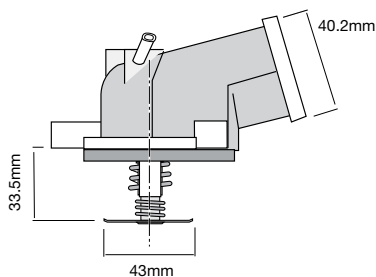

Temp. Part No.
87°C TT351-189P
89°C TT351-192P

TT352 Series

Bypass style thermostat integrated into housing, 3 bolt holes, gasket included.

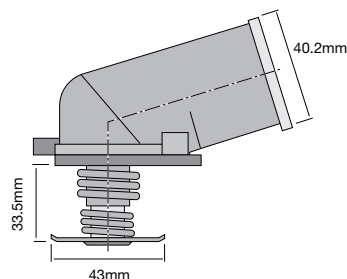

Temp. Part No.
87°C TT352-189P
89°C TT352-192P

TT353 Series

Bypass style thermostat integrated into housing, 3 bolt holes, gasket included.

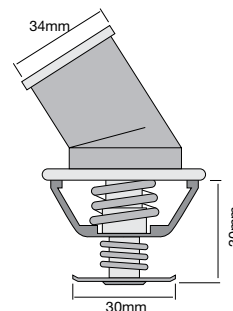

Temp. Part No.
82°C TT353-180P
92°C TT353-198P

TT354 Series

Bypass style thermostat with inverse jiggle pin.

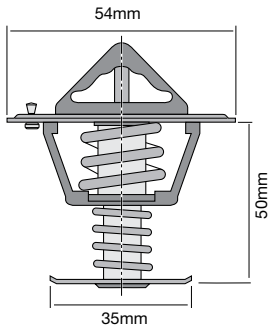

Temp. Part No.
 82°C TT354-180P
 87°C TT354-189P
 89°C TT354-192P

TT363 Series

Bypass style thermostat with jiggle pin.

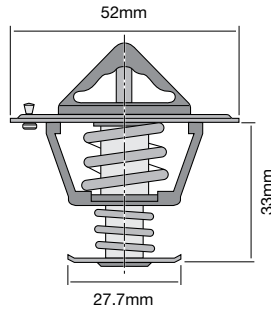

Temp. Part No.
 82°C TT363-180

TT367 Series

Offset conventional style thermostat with jiggle pin.

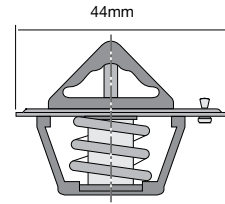

Temp. Part No.
 83°C TT367-182

TT368 Series

Bypass style thermostat with pressure relief hole.

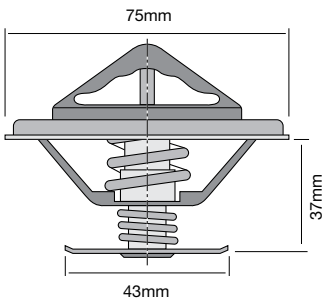

Temp. Part No.
 82°C TT368-180

TT369 Series

Bypass style thermostat with pressure relief hole.

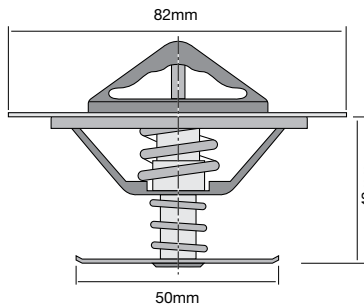

Temp. Part No.
 77°C TT369-170P
 82°C TT369-180P

TT370 Series

Bypass style thermostat with inverse jiggle pin.

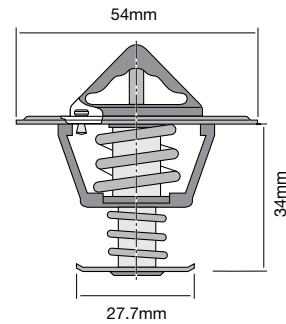

Temp. Part No.
 77°C TT370-170

TT371 Series

Bypass style thermostat with double jiggle pins.

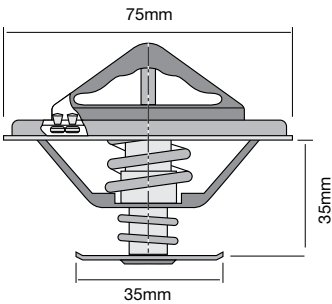

Temp. Part No.
 82°C TT371-180

TT372 Series

Bypass style thermostat with double jiggle pins.

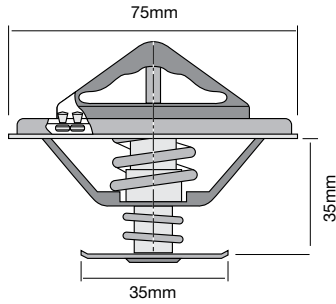

Temp. Part No.
 82°C TT372-180

TT373 Series

Bypass style thermostat with jiggle pin.

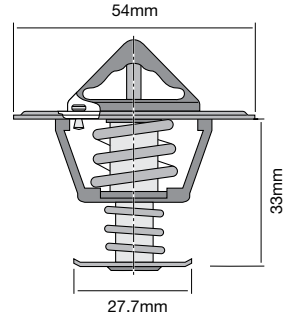

Temp. Part No.
 82°C TT373-180

TT374 Series

Offset conventional style thermostat with jiggle pin, gasket included.

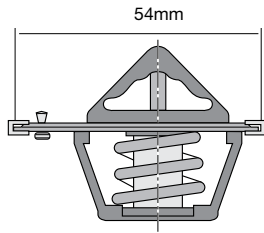

Temp. Part No.
82°C TT374-180

TT375 Series

Bypass style thermostat.

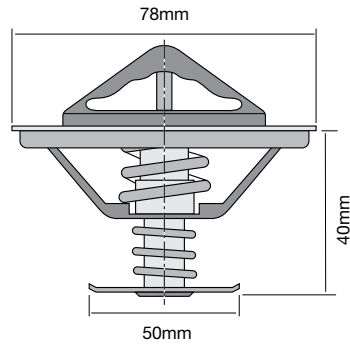

Temp. Part No.
77°C TT375-170P

TT377 Series

Bypass style thermostat with double jiggle pins.

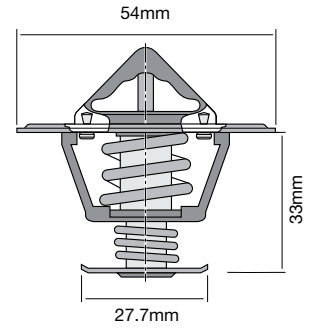

Temp. Part No.
77°C TT377-170
82°C TT377-180

TT378 Series

Bypass style thermostat with jiggle pin.

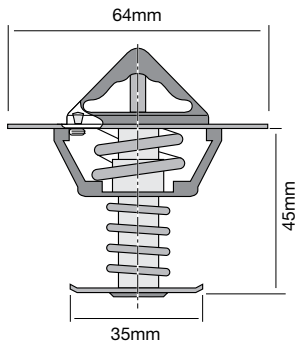

Temp. Part No.
77°C TT378-170

TT379 Series

Bypass style thermostat integrated into housing, 3 bolt holes, gasket included.

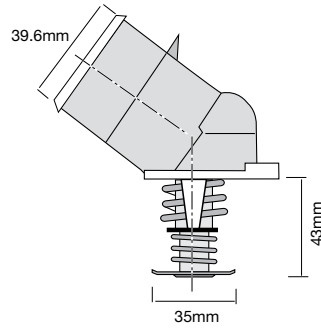

Temp. Part No.
71°C TT379-160P
82°C TT379-180P
86°C TT379-187P

TT380 Series

Bypass style thermostat with jiggle pin.

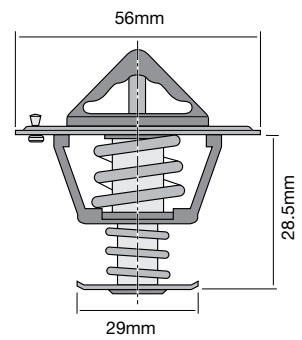

Temp. Part No.
82°C TT380-180

TT381 Series

Bypass style thermostat with inverse jiggle pin.

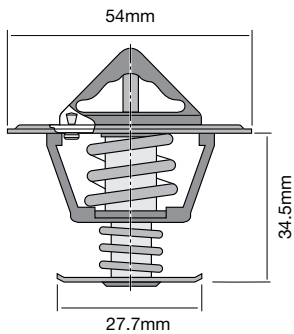

Temp. Part No.
77°C TT381-170
82°C TT381-180

TT382 Series

Bypass style thermostat with jiggle pin.

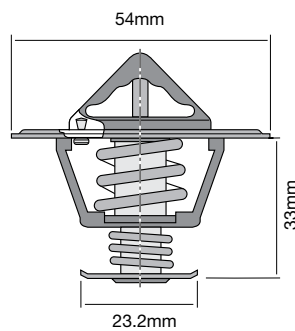

Temp. Part No.
85°C TT382-185

TT384 Series

Offset bypass style thermostat with inverse jiggle pin, gasket included.

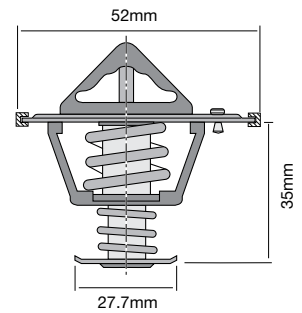

Temp. Part No.
85°C TT384-185

TT385 Series

Special design thermostat insert.
Thermostat housing TTH385P sold separately 2 bolt holes, gasket included.

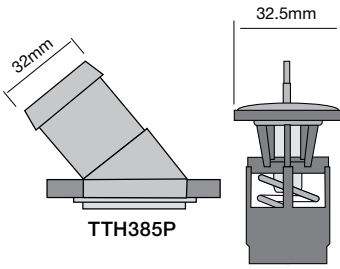

Temp. Part No.
85°C TT385-185P
88°C TT385-190P

TT388 Series

Bypass style thermostat with jiggle pin, gasket included.

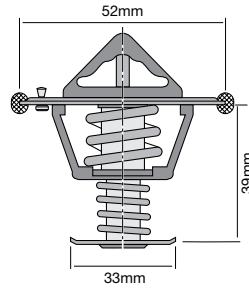

Temp. Part No.
82°C TT388-180
88°C TT388-190

TT390 Series

Bypass style thermostat with jiggle pin, gasket included.

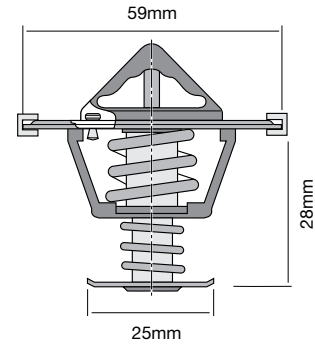

Temp. Part No.
91°C TT390-195

TT391 Series

Bypass style thermostat integrated into housing, 3 bolt holes, gasket included.

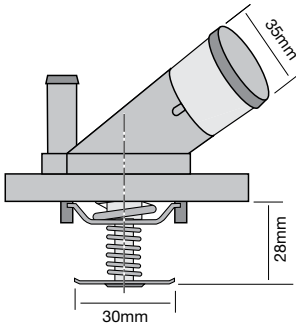

Temp. Part No.
77°C TT391-170P
82°C TT391-180P

TT394 Series

Bypass style thermostat integrated into housing with jiggle pin, 3 bolt holes, gasket included.

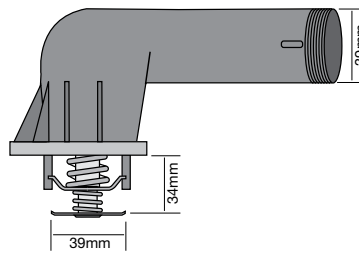

Temp. Part No.
95°C TT394-203P

TT405 Series

Special design thermostat.

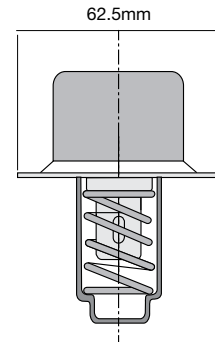

Temp. Part No.
79°C TT405-174P

TT410 Series

Bypass style thermostat with inverse jiggle pin.

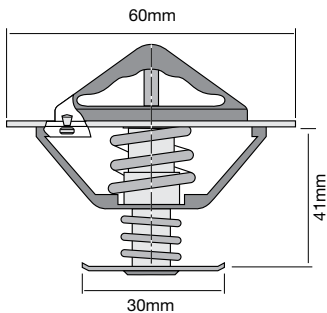

Temp. Part No.
71°C TT410-160
77°C TT410-170
82°C TT410-180

TT411 Series

Bypass style thermostat with inverse jiggle pin, gasket included.

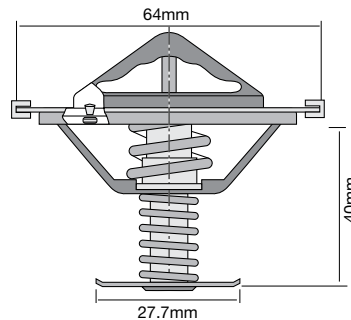

Temp. Part No.
85°C TT411-185

TT412 Series

Bypass style thermostat with inverse jiggle pin.

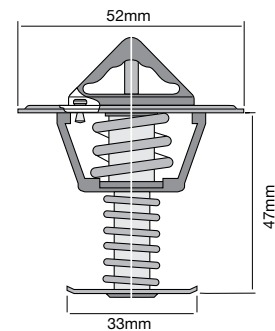

Temp. Part No.
80°C TT412-176

TT414 Series

Special design conventional style thermostat with secondary thermostat & jiggle pin.

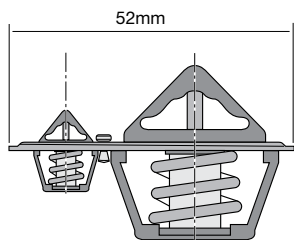

Temp. Part No.
88°C TT414-190

TT418 Series

Special design conventional style thermostat with pressure relief hole.

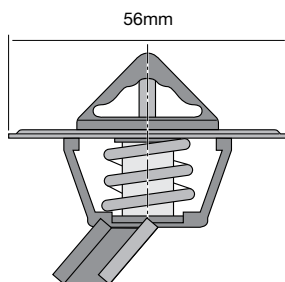

Temp. Part No.
77°C TT418-170P

TT420 Series

Bypass style thermostat with inverse jiggle pin, gasket included.

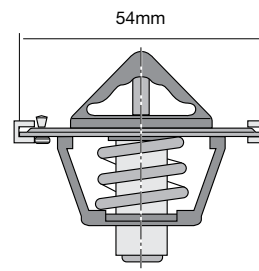

Temp. Part No.
91°C TT420-195

TT425 Series

Offset conventional style thermostat with jiggle pin, gasket included.

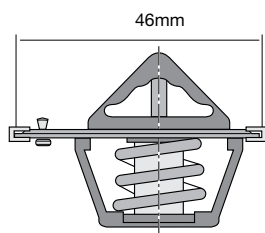

Temp. Part No.
91°C TT425-195

TT427 Series

Bypass style thermostat with inverse jiggle pin, gasket included.

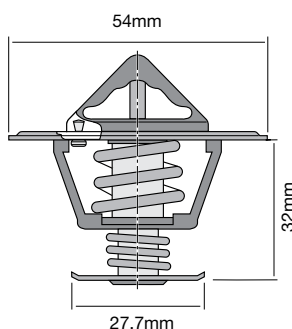

Temp. Part No.
82°C TT427-180

TT431 Series

Bypass style thermostat integrated into housing with jiggle pin, 3 bolt holes, gasket included.

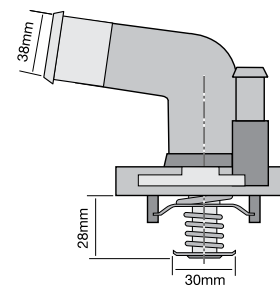

Temp. Part No.
82°C TT431-180P

TT432 Series

Bypass style thermostat integrated into housing with inverse jiggle pin, 3 bolt holes, gasket included.

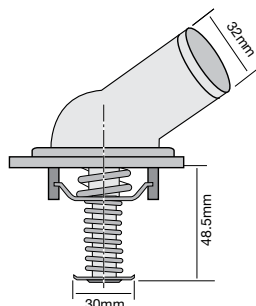

Temp. Part No.
89°C TT432-192P

TT436 Series

Bypass style thermostat integrated into housing, 3 bolt holes, gasket included.

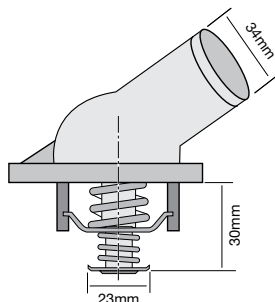

Temp. Part No.
92°C TT436-198P

TT438 Series

Conventional style thermostat integrated into housing, 2 bolt holes, gasket included.

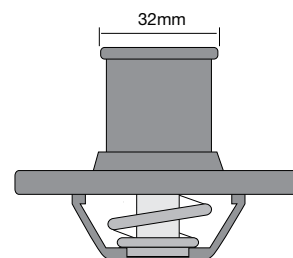

Temp. Part No.
89°C TT438-192P

TT439 Series

Special design bypass style thermostat integrated into housing.

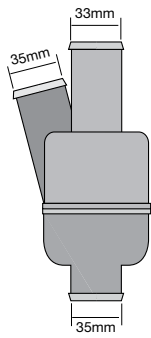

Temp. Part No.
82°C TT439-180P

TT440 Series

Special design bypass style thermostat integrated into housing.

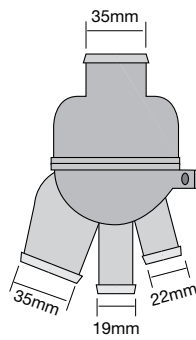

Temp. Part No.
82°C TT440-180P

TT441 Series

Offset bypass style thermostat with inverse jiggle pin, gasket included.

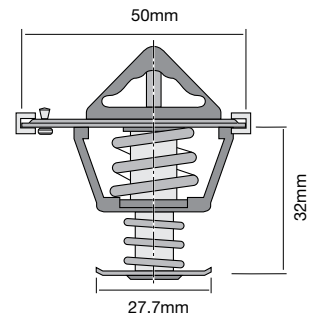

Temp. Part No.
77°C TT441-170

TT443 Series

Bypass style thermostat integrated into housing, 2 bolt holes, gasket included.

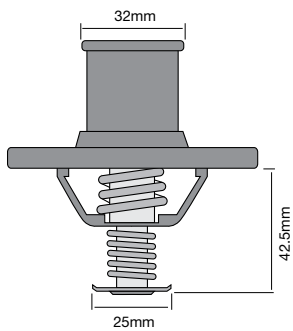

Temp. Part No.
89°C TT443-192P

TT444 Series

Bypass style thermostat with inverse jiggle pin, gasket included.

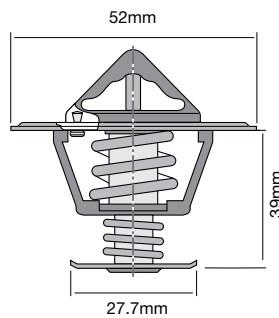

Temp. Part No.
82°C TT444-180

TT445 Series

Offset conventional style thermostat with jiggle pin, gasket included.

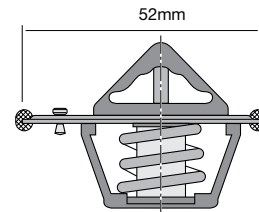

Temp. Part No.
82°C TT445-180
89°C TT445-192

TT446 Series

Offset bypass style thermostat with inverse jiggle pin, gasket included.

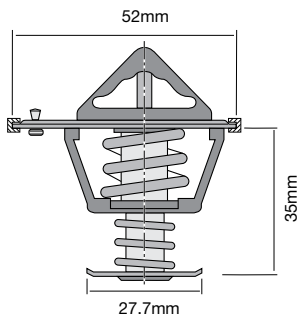

Temp. Part No.
89°C TT446-192

TT449 Series

Conventional style thermostat with inverse jiggle pin.

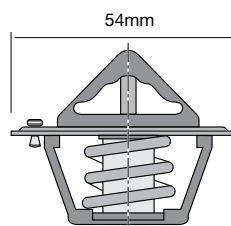

Temp. Part No.
88°C TT449-190

TT456 Series

Bypass style thermostat with inverse jiggle pin, gasket included.

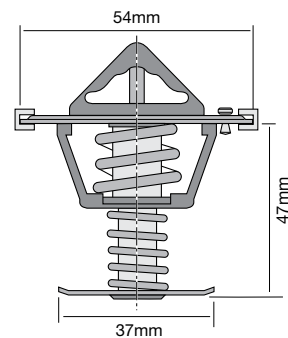

Temp. Part No.
71°C TT456-160
82°C TT456-180
86°C TT456-187

TT457 Series

Conventional style thermostat with pressure relief hole, gasket included.

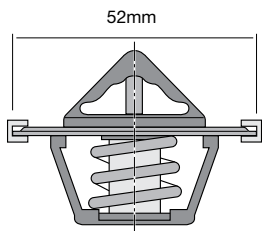

Temp. Part No.
96°C TT457-205

TT458 Series

Bypass style thermostat integrated into housing, 2 bolt holes, gasket included.

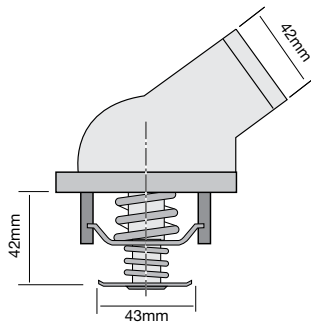

Temp. Part No.
87°C TT458-189P
89°C TT458-192P

TT459 Series

Special design, gasket included.

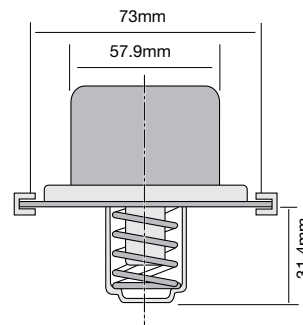

Temp. Part No.
79°C TT459-174P

TT465 Series

Offset conventional style thermostat with jiggle pin.

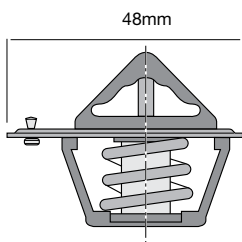

Temp. Part No.
91°C TT465-195

TT467 Series

Bypass style thermostat integrated into housing, 4 bolt holes. Coolant sensor & gasket included.

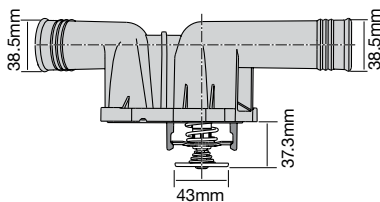

Temp. Part No.
97°C TT467-206P
103°C TT467-217P

TT468 Series

Bypass style thermostat integrated into housing, 4 bolt holes. Coolant sensor & gasket included.

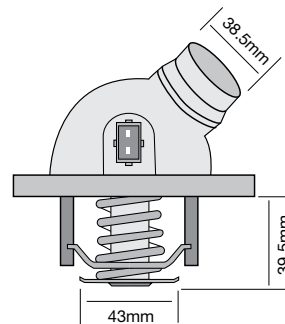

Temp. Part No.
105°C TT468-221P

TT471 Series

Bypass style thermostat integrated into housing, 4 bolt holes, with jiggle pin, gasket included.

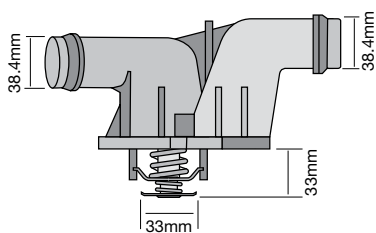

Temp. Part No.
89°C TT471-192P

TT478 Series

Bypass style thermostat integrated into housing with jiggle pin, 3 bolt holes, gasket included.

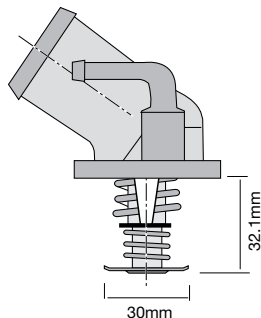

Temp. Part No.
92°C TT478-198

TT479 Series

Special design bypass style thermostat insert with jiggle pin.

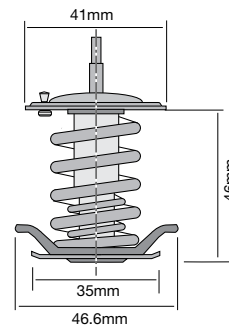

Temp. Part No.
82°C TT479-180P

TT480 Series

Bypass style thermostat with inverse jiggle pin.

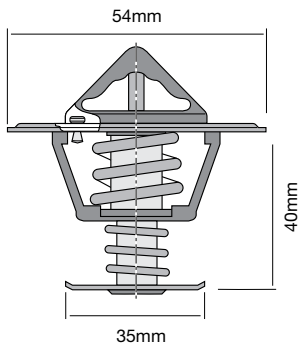

Temp. Part No.
82°C TT480-180

TT498 Series

Special design thermostat with jiggle pin integrated into housing, 4 bolt holes. Coolant sensor & gasket included.

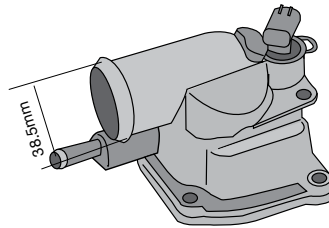

Temp. Part No.
87°C TT498-189

TT503 Series

Bypass style thermostat integrated into housing, 4 bolt holes. Coolant sensor & gasket included.

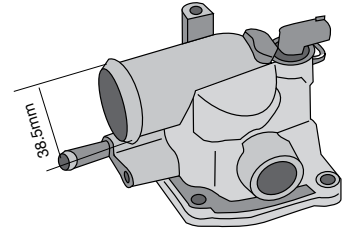

Temp. Part No.
87°C TT503-189
89°C TT503-192P
92°C TT503-198

TT504 Series

Special design thermostat with jiggle pin integrated into housing, 4 bolt holes. Coolant sensor & gasket included.

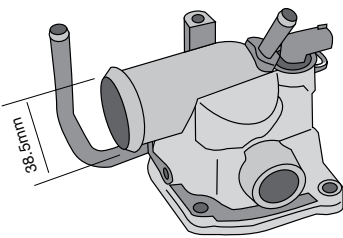

Temp. Part No.
87°C TT504-189

TT505 Series

Bypass style thermostat integrated into housing, 4 bolt holes. Coolant sensor & gasket included.

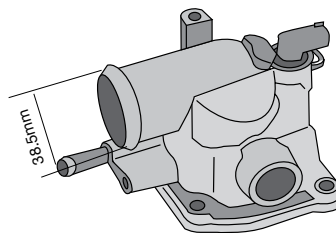

Temp. Part No.
87°C TT505-189
92°C TT505-198

TT506 Series

Special design thermostat integrated into housing, 2 bolt holes, gasket included.

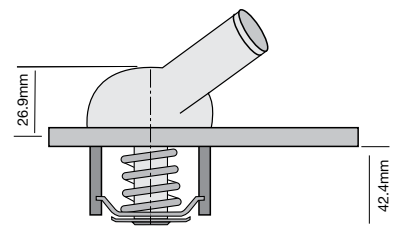

Temp. Part No.
88°C TT506-190

TT507 Series

Special design thermostat with inverse jiggle pin integrated into housing, gasket included.

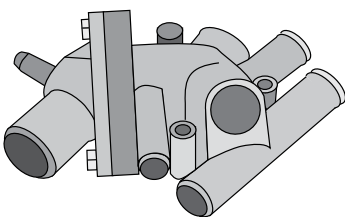

Temp. Part No.
89°C TT507-192

TT512 Series

Bypass style thermostat with inverse jiggle pin integrated into housing, 3 bolt holes, gasket included.

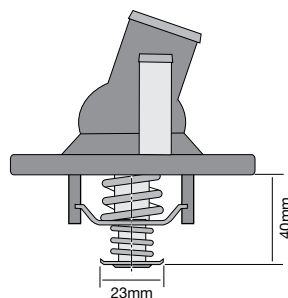

Temp. Part No.
82°C TT512-180P

TT514 Series

Bypass style thermostat with inverse jiggle pin integrated into housing, 3 bolt holes, gasket included.

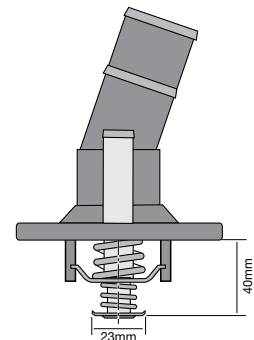

Temp. Part No.
82°C TT514-180P
89°C TT514-192P

TT515 Series

Special design thermostat integrated into housing with jiggle pin, gasket included.

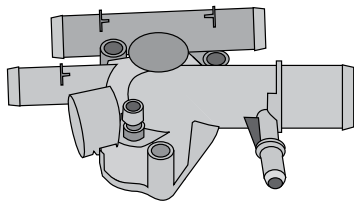

Temp. Part No.
89°C TT515-192

TT518 Series

Bypass style thermostat.

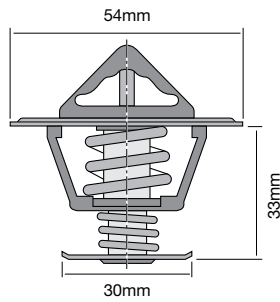

Temp. Part No.
77°C TT518-170

TT519 Series

Bypass style thermostat, gasket included.

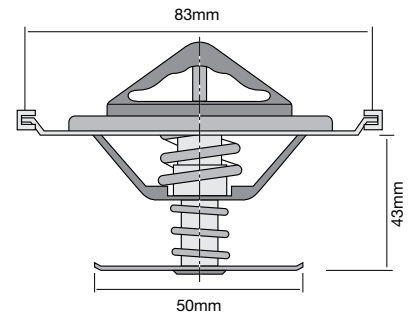

Temp. Part No.
82°C TT519-180P

TT522 Series

Bypass style thermostat integrated into housing with inverse jiggle pin, 3 bolt holes, gasket included.

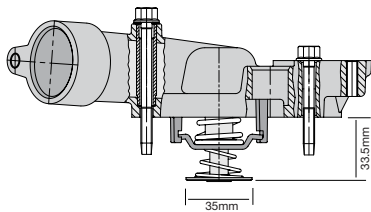

Temp. Part No.
82°C TT522-180P

TT523 Series

Bypass style thermostat with inverse jiggle pin, gasket included.

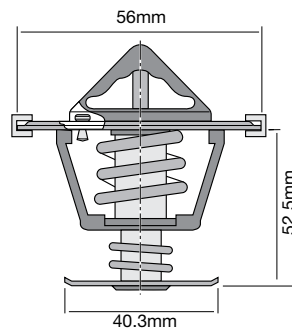

Temp. Part No.
71°C TT523-160
77°C TT523-170
86°C TT523-187

TT525 Series

Conventional style thermostat integrated into housing, 2 bolt holes, gasket included.

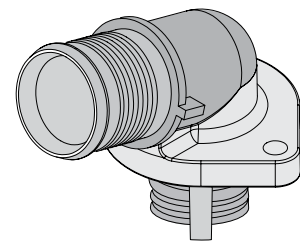

Temp. Part No.
89°C TT525-192

TT528 Series

Bypass style thermostat with inverse jiggle pin, gasket included.

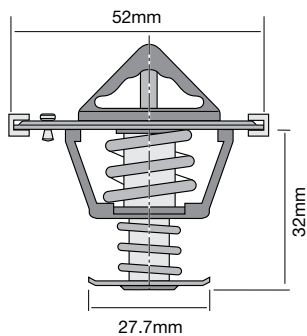

Temp. Part No.
82°C TT528-180

TT531 Series

Conventional style thermostat with inverse jiggle pin, gasket included.

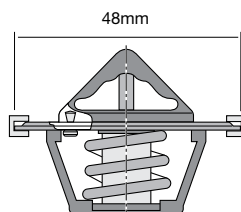

Temp. Part No.
82°C TT531-180

TT532 Series

Bypass style thermostat with inverse jiggle pin, gasket included.

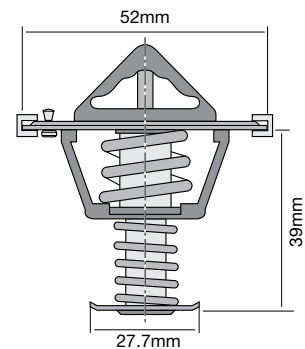

Temp. Part No.
82°C TT532-180

TT533 Series

Bypass style thermostat with inverse jiggle pin, gasket included.

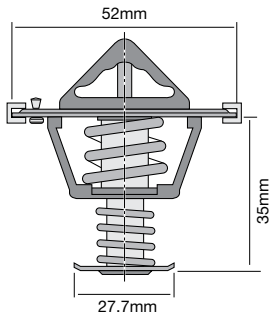

Temp. Part No.
79°C TT533-174

TT534 Series

Bypass style thermostat with inverse jiggle pin, gasket included.

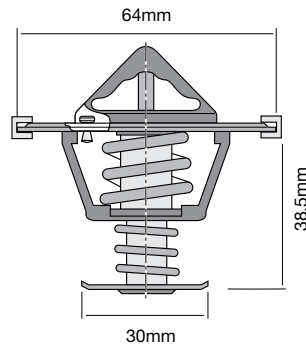

Temp. Part No.
82°C TT534-180

TT538 Series

Bypass style thermostat integrated into housing, gasket included.

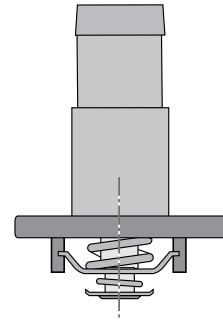

Temp. Part No.
86°C TT538-187

TT544 Series

Special design thermostat integrated into housing, gasket included.

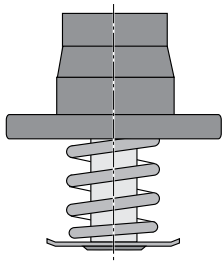

Temp. Part No.
87°C TT544-189

TT547 Series

Special design thermostat integrated into housing. Coolant sensor & gasket included.

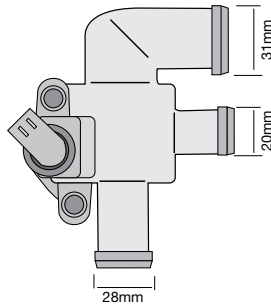

Temp. Part No.
91°C TT547-195

TT550 Series

Bypass style thermostat integrated into housing with jiggle pin, 3 bolt holes. Coolant sensor & gasket included.

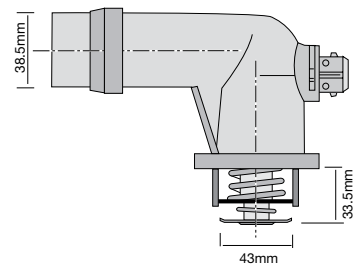

Temp. Part No.
105°C TT550-221P

TT551 Series

Bypass style thermostat with jiggle pin.

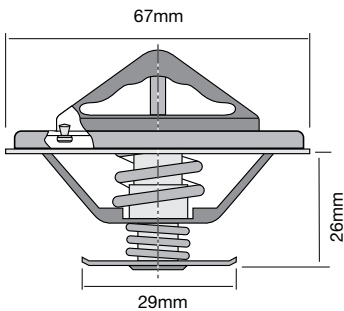

Temp. Part No.
78°C TT551-172

TT554 Series

Bypass style thermostat integrated into housing with jiggle pin, 3 bolt holes, gasket included.

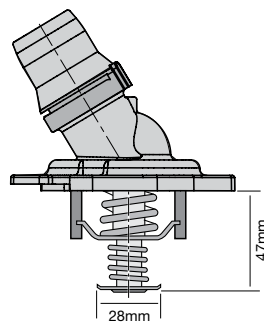

Temp. Part No.
77°C TT554-170

TT557 Series

Bypass style thermostat integrated into housing with jiggle pin, 3 bolt holes, gasket included.

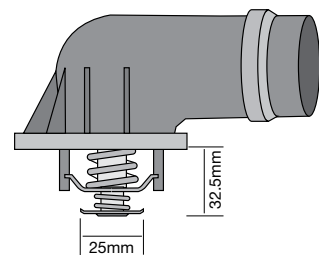

Temp. Part No.
95°C TT557-203

TT561 Series

Special design conventional style thermostat with secondary thermostat & jiggle pin.

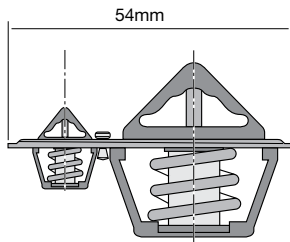

Temp. Part No.
88°C TT561-190

TT564 Series

Offset bypass style thermostat with inverse jiggle pin.

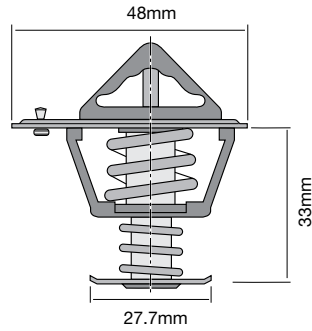

Temp. Part No.
82°C TT564-180

TT565 Series

Offset conventional style thermostat with inverse jiggle pin.

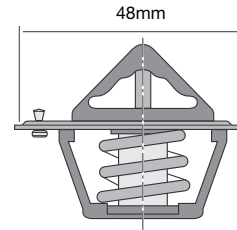

Temp. Part No.
82°C TT565-180

TT566 Series

Special design thermostat integrated into housing, 3 bolt holes. Coolant sensor & gasket included.

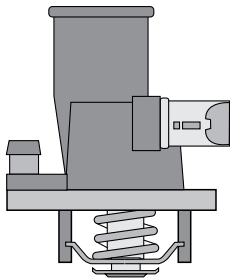

Temp. Part No.
84°C TT566-183

TT568 Series

Special design thermostat integrated into housing, gasket included.

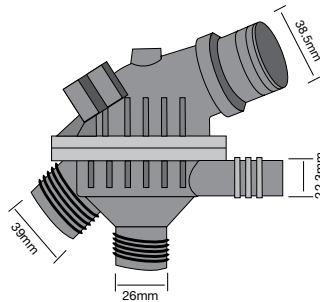

Temp. Part No.
103°C TT568-217

TT569 Series

Bypass style thermostat integrated into housing. Coolant sensor & gasket included.

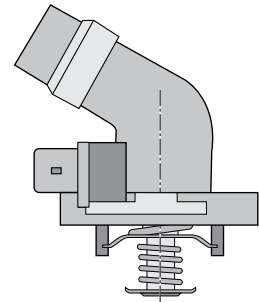

Temp. Part No.
109°C TT569-228

TT570 Series

Bypass style thermostat integrated into housing, 2 bolt holes. Coolant sensor & gasket included.

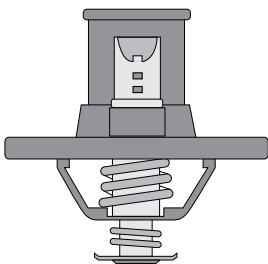

Temp. Part No.
105°C TT570-221

TT571 Series

Special design thermostat integrated into housing, 4 bolt holes, gasket included.

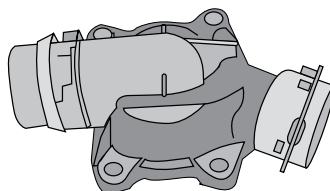

Temp. Part No.
88°C TT571-190

TT572 Series

Bypass style thermostat integrated into housing, 3 bolt holes. Coolant sensor & gasket included.

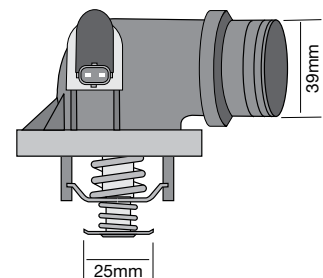

Temp. Part No.
105°C TT572-221

TT573 Series

Special design thermostat integrated into housing, 2 bolt holes. Coolant sensor & gasket included.

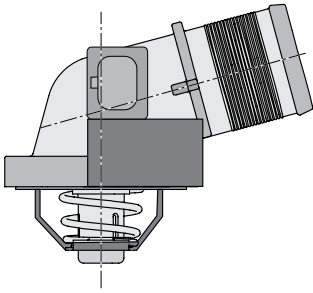

Temp. Part No.
103°C TT573-217

TT574 Series

Special design thermostat integrated into housing, 4 bolt holes. Coolant sensor & gasket included.

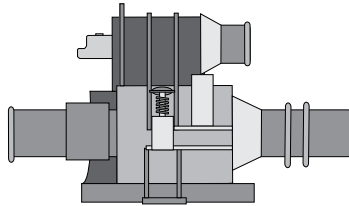

Temp. Part No.
83°C TT574-181

TT576 Series

Special design thermostat integrated into housing, 2 bolt holes, gasket included.

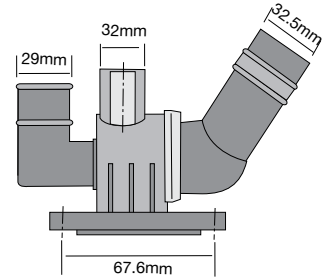

Temp. Part No.
87°C TT576-189

TT578 Series

Special design thermostat integrated into housing, 3 bolt holes, gasket included.

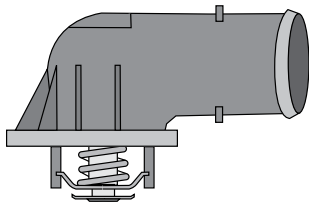

Temp. Part No.
87°C TT578-189

TT580 Series

Special design thermostat integrated into housing, 2 bolt holes, gasket included.

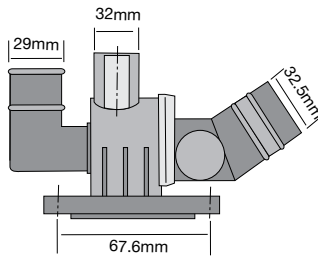

Temp. Part No.
87°C TT580-189

TT582 Series

Special design thermostat integrated into housing, 2 bolt holes, gasket included.

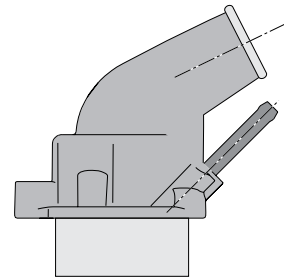

Temp. Part No.
87°C TT582-189P

TT584 Series

Special design thermostat integrated into housing, 4 bolt holes, gasket included.

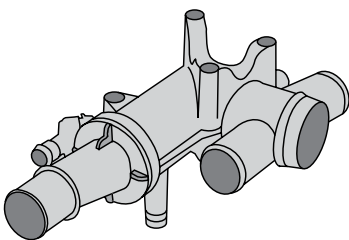

Temp. Part No.
84°C TT584-183

TT596 Series

Special design thermostat integrated into housing, 3 bolt holes. Coolant sensor & gasket included.

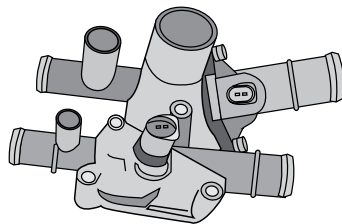

Temp. Part No.
105°C TT596-221

TT597 Series

Special design thermostat integrated into housing, 2 bolt holes, gasket included.

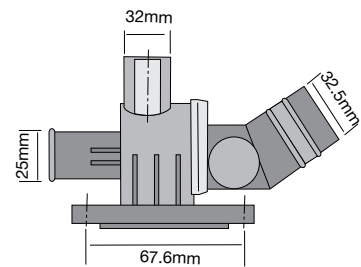

Temp. Part No.
87°C TT597-189

TT599 Series

Special design thermostat integrated into housing, 3 bolt holes. Coolant sensor & gasket included.

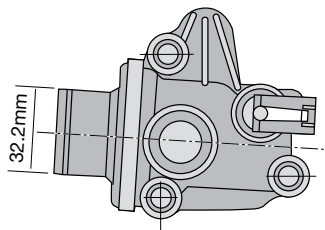

Temp. Part No.
87°C TT599-189

TT600 Series

Special design thermostat integrated into housing, gasket included.

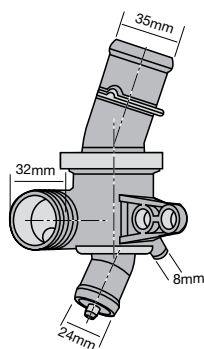

Temp. Part No.
80°C TT600-176

TT601 Series

Special design thermostat integrated into housing, 2 bolt holes, gasket included.

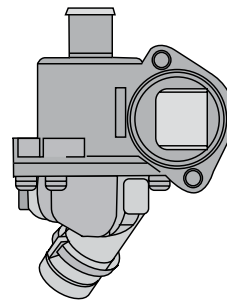

Temp. Part No.
100°C TT601-212

TT606 Series

Bypass style thermostat integrated into housing, 3 bolt holes. Coolant sensor & gasket included.

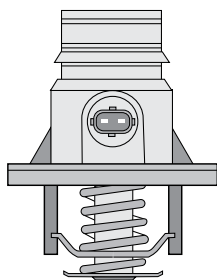

Temp. Part No.
105°C TT606-221

TT611 Series

Bypass style thermostat integrated into housing, 4 bolt holes. Coolant sensor & gasket included.

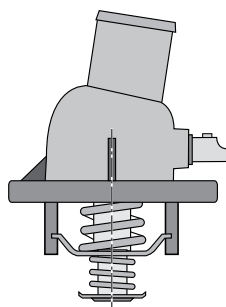

Temp. Part No.
105°C TT611-221

TT616 Series

Special design thermostat integrated into housing. Coolant sensor & gasket included.

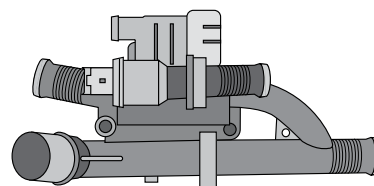

Temp. Part No.
83°C TT616-181

TT618 Series

Special design thermostat integrated into housing, 4 bolt holes. Coolant sensor & gasket included.

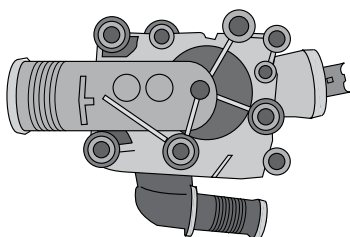

Temp. Part No.
91°C TT618-195

TT620 Series

Offset bypass style thermostat with jiggle pin, gasket included.

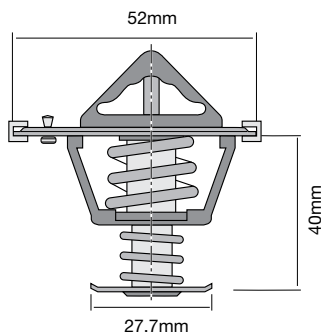

Temp. Part No.
82°C TT620-180

TT622 Series

Bypass style thermostat integrated into housing, gasket included.

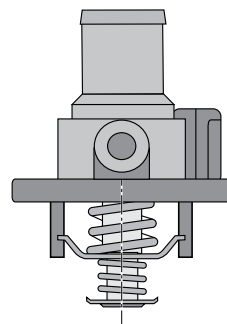

Temp. Part No.
83°C TT622-181

TT623 Series

Bypass style thermostat integrated into housing, gasket included.

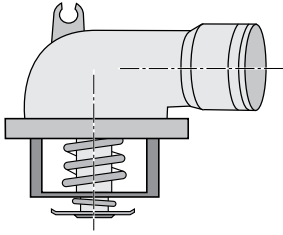

Temp. Part No.
87°C TT623-189

TT624 Series

Special design thermostat integrated into housing, 3 bolt holes, gasket included.

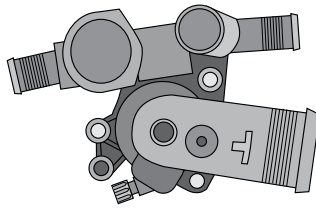

Temp. Part No.
89°C TT624-192

TT626 Series

Special design thermostat integrated into housing, 3 bolt holes. Coolant sensor & gasket included.

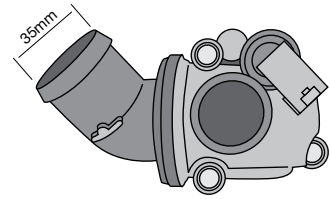

Temp. Part No.
87°C TT626-189

TT627 Series

Special design thermostat integrated into housing, 2 bolt holes. Coolant sensor & gasket included.

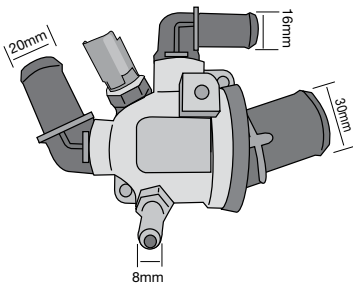

Temp. Part No.
88°C TT627-190

TT628 Series

Bypass style thermostat integrated into housing, 2 bolt holes, gasket included.

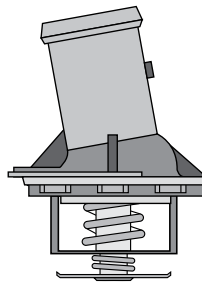

Temp. Part No.
87°C TT628-189

TT629 Series

Bypass style thermostat integrated into housing, 2 bolt holes, gasket included.

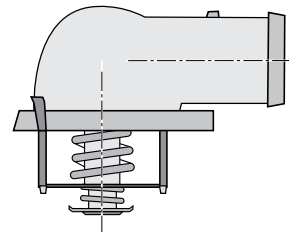

Temp. Part No.
87°C TT629-189

TT630 Series

Conventional style thermostat.

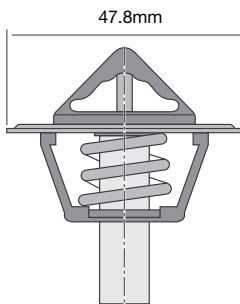

Temp. Part No.
91°C TT630-195

TT631 Series

Bypass style thermostat integrated into housing, gasket included.

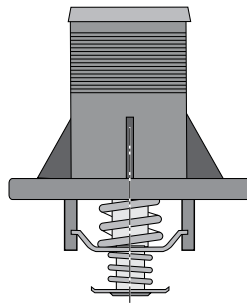

Temp. Part No.
82°C TT631-180

TT635 Series

Bypass style thermostat with inverse jiggle pin, gasket included.

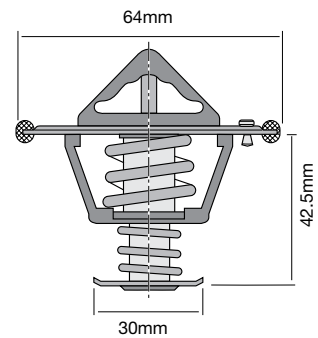

Temp. Part No.
82°C TT635-180

TT636 Series

Bypass style thermostat with inverse jiggle pin integrated into housing, 3 bolt holes, gasket included.

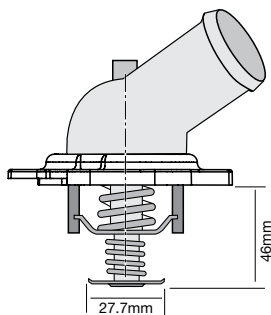

Temp. Part No.
78°C TT636-172

TT637 Series

Bypass style thermostat integrated into housing, gasket included.

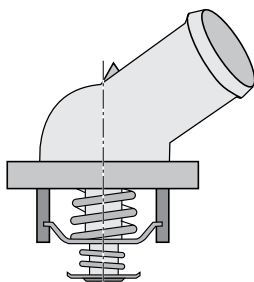

Temp. Part No.
82°C TT637-180

TT639 Series

Bypass style thermostat with jiggle pin integrated into housing, 4 bolt holes, gasket included.

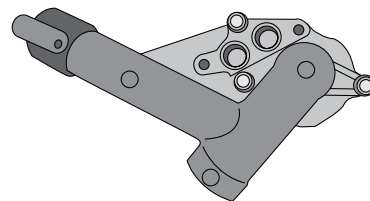

Temp. Part No.
82°C TT639-180P

TT657 Series

Offset conventional style thermostat with pressure relief hole, gasket included.

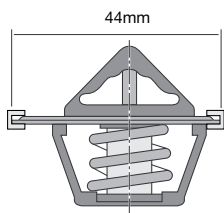

Temp. Part No.
95°C TT657-203

TT658 Series

Bypass style thermostat with jiggle pin, gasket included.

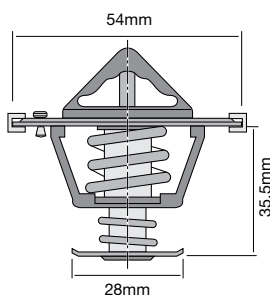

Temp. Part No.
77°C TT658-170

TT659 Series

Bypass style thermostat integrated into housing with jiggle pin, 3 bolt holes, gasket included.

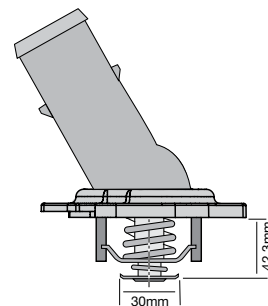

Temp. Part No.
82°C TT659-180

TT660 Series

Bypass style thermostat integrated into housing with jiggle pin, 3 bolt holes, gasket included.

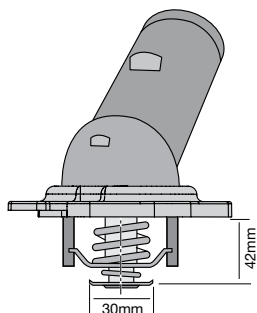

Temp. Part No.
82°C TT660-180

TT1120 Series

Bypass style thermostat integrated into housing, 2 bolt holes, gasket included.

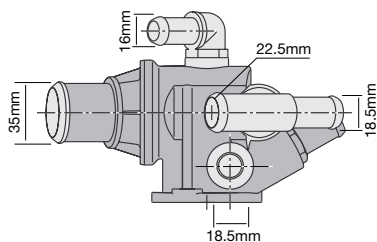

Temp. Part No.
83°C TT1120-181P

TT1122 Series

Bypass style thermostat integrated into housing, 2 bolt holes, gasket included.

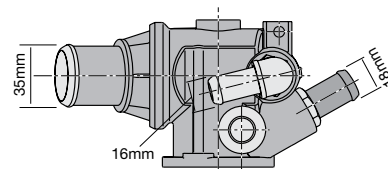

Temp. Part No.
88°C TT1122-190P

TT1174 Series

Bypass style thermostat integrated into housing, 3 bolt holes, gasket included.

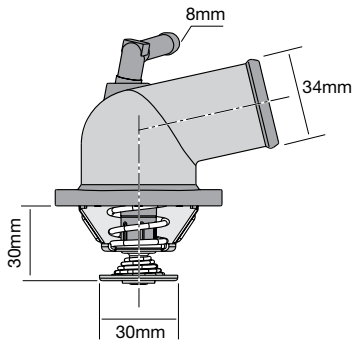

Temp. Part No.
92°C TT1174-198P

TT1308 Series

Bypass style thermostat integrated into housing, gasket included.

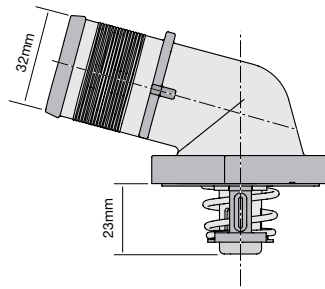

Temp. Part No.
86°C TT1308-186P

TT1309 Series

Special design, gasket included.

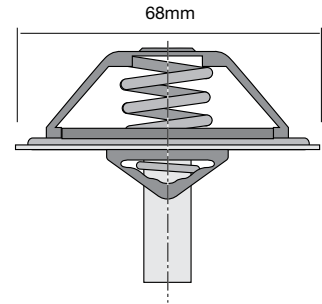

Temp. Part No.
80°C TT1309-176
85°C TT1309-185

TT1326 Series

Bypass style thermostat, gasket included.

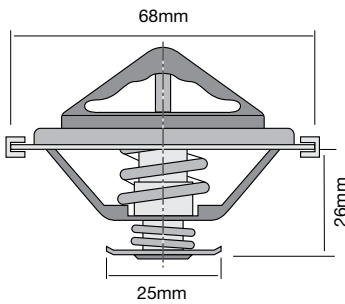

Temp. Part No.
84°C TT1326-183

TT1350 Series

Bypass style thermostat integrated into housing, 2 bolt holes, gasket included.

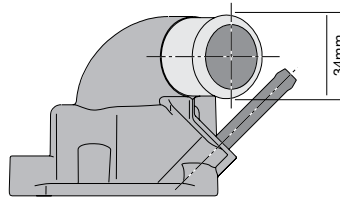

Temp. Part No.
92°C TT1350-198P

TT1370 Series

Bypass style thermostat with jiggle pin, gasket included.

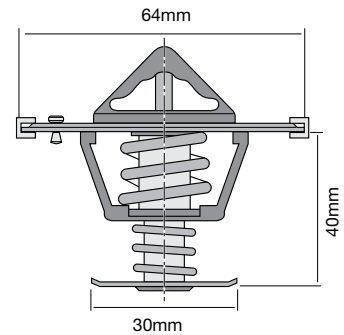

Temp. Part No.
82°C TT1370-180

TT1404 Series

Bypass style thermostat with jiggle pin, gasket included.

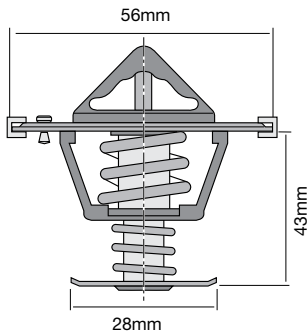

Temp. Part No.
82°C TT1404-180

TT1405 Series

Special design thermostat integrated into housing, 2 bolt holes. Coolant sensor & gasket included.

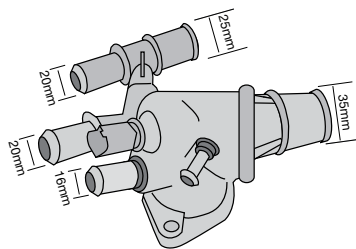

Temp. Part No.
88°C TT1405-190

TT1427 Series

Bypass style thermostat integrated into housing, 4 bolt holes, gasket included.

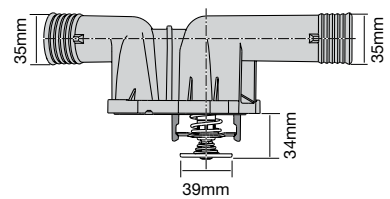

Temp. Part No.
95°C TT1427-203P

TT1564 Series

Bypass style thermostat integrated into housing, 2 bolt holes, gasket included.

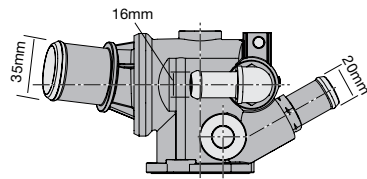

Temp. Part No.
88°C TT1564-190P

TT1580 Series

Special design thermostat integrated into housing, 2 bolt holes. Coolant sensor & gasket included.

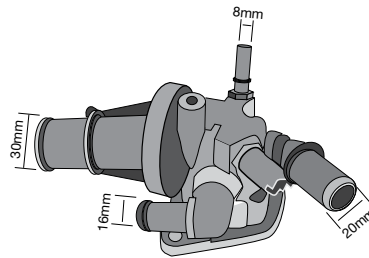

Temp. Part No.
88°C TT1580-190

TT1606 Series

Special design thermostat integrated into housing. Coolant sensor & gasket included.

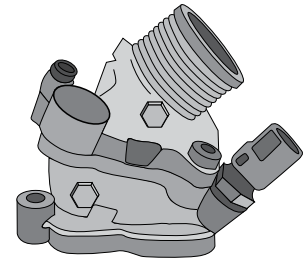

Temp. Part No.
90°C TT1606-194

TT1636 Series

Special design thermostat integrated into housing, gasket included.

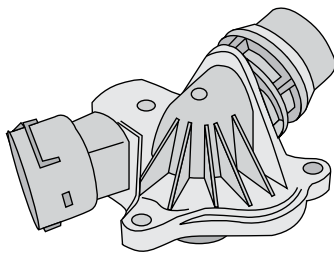

Temp. Part No.
88°C TT1636-190

TT1669 Series

Special design thermostat integrated into housing, 2 bolt holes. Coolant sensor & gasket included.

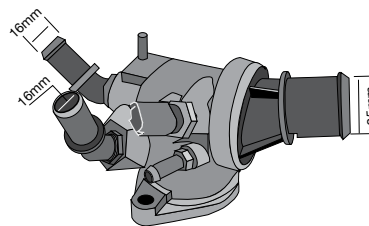

Temp. Part No.
88°C TT1669-190

TT1670 Series

Special design thermostat integrated into housing, 2 bolt holes. Coolant sensor & gasket included.

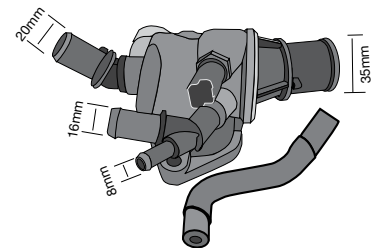

Temp. Part No.
88°C TT1670-190

TT1672 Series

Special design thermostat integrated into housing. Coolant sensor & gasket included.

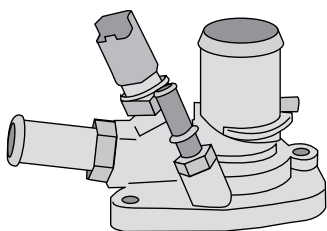

Temp. Part No.
88°C TT1672-190

TT1675 Series

Special design thermostat integrated into housing, 2 bolt holes. Coolant sensor & gasket included.

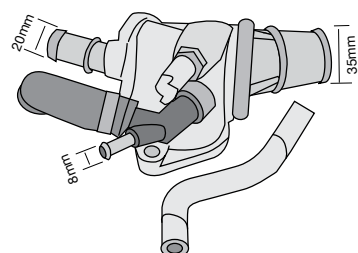

Temp. Part No.
88°C TT1675-190

TT1685 Series

Bypass style thermostat, gasket included.

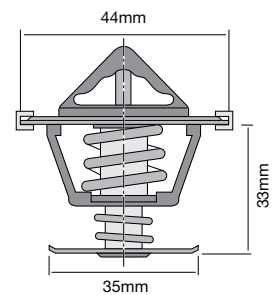

Temp. Part No.
88°C TT1685-190

TT1686 Series

Special design thermostat insert assembly, gasket included.

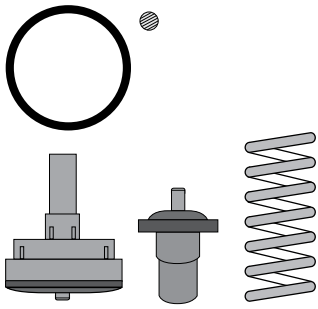

Temp. Part No.
95°C TT1686-203

TT1689 Series

Special design thermostat insert assembly, gasket included.

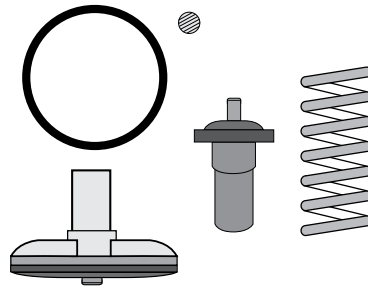

Temp. Part No.
80°C TT1689-176

TT1694 Series

Bypass style thermostat with inverse jiggle pin, gasket included.

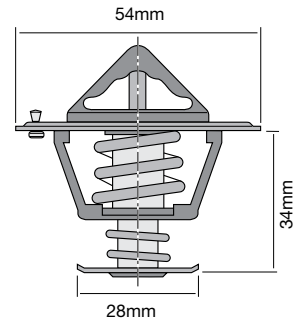

Temp. Part No.
80°C TT1694-176

TT1699 Series

Special design thermostat integrated into housing. Coolant sensor & gasket included.

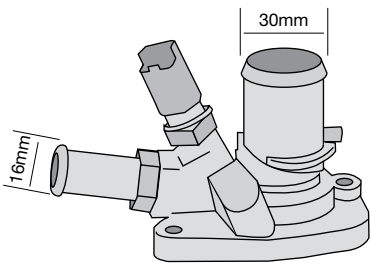

Temp. Part No.
88°C TT1699-190

TT1701 Series

Special design thermostat integrated into housing. Coolant sensor & gasket included.

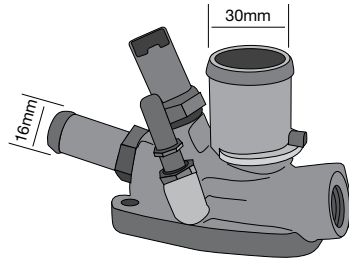

Temp. Part No.
80°C TT1701-176

TT1706 Series

Special design thermostat integrated into housing. Coolant sensor & gasket included.

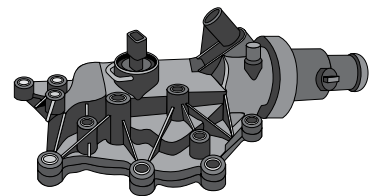

Temp. Part No.
89°C TT1706-192

TT1712 Series

Conventional style thermostat with jiggle pin, gasket included.

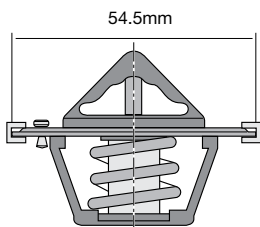

Temp. Part No.
82°C TT1712-180

TT1728 Series

Bypass style thermostat with jiggle pin, gasket included.

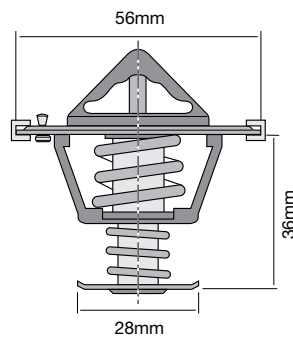

Temp. Part No.
82°C TT1728-180

TT1731 Series

Bypass style thermostat with jiggle pin, gasket included.

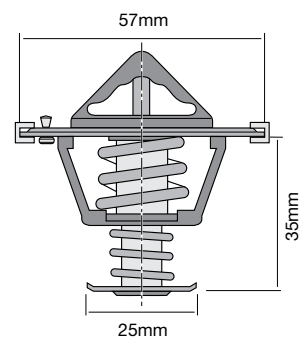

Temp. Part No.
90°C TT1731-194

TT1732 Series

Special design thermostat integrated into housing, 2 bolt holes. Coolant sensor & gasket included.

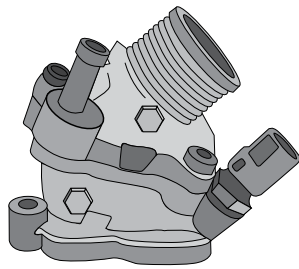

Temp. Part No.
90°C TT1732-194

TT1733 Series

Special design thermostat integrated into housing, 2 bolt holes. Coolant sensor & gasket included.

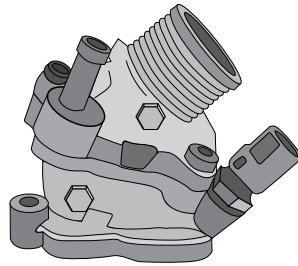

Temp. Part No.
90°C TT1733-194

TT1742 Series

Bypass style thermostat with jiggle pin, gasket included.

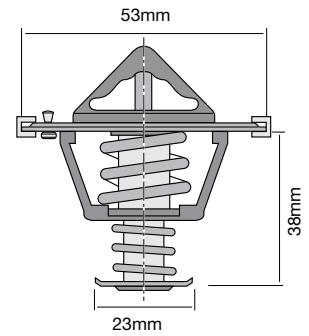

Temp. Part No.
95°C TT1742-203

TT1743 Series

Special design thermostat insert with jiggle pin, gasket included.

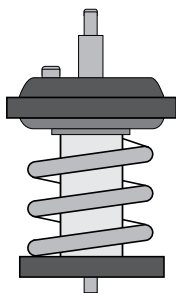

Temp. Part No.
95°C TT1743-203

TT1745 Series

Special design thermostat insert with jiggle pin, gasket included.

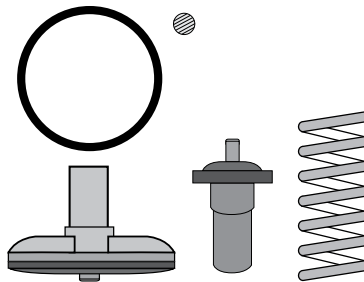

Temp. Part No.
83°C TT1745-181

TT1747 Series

Special design thermostat integrated into housing. Coolant sensor & gasket included.

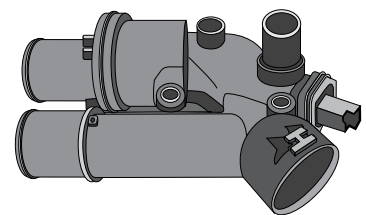

Temp. Part No.
83°C TT1747-181

TT2000 Series

Conventional style thermostat with jiggle pin.
High flow version of TT1 series.

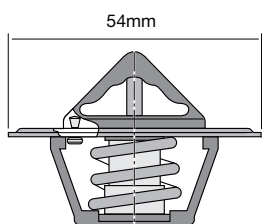

| | |
|-----------------|-----------------|
| Temp. Part No. | Temp. Part No. |
| 71°C TT2000-160 | 89°C TT2000-192 |
| 77°C TT2000-170 | 91°C TT2000-195 |
| 82°C TT2000-180 | |
| 88°C TT2000-190 | |

TT2001 Series

Conventional style thermostat with jiggle pin.
High flow version of TT6 series.

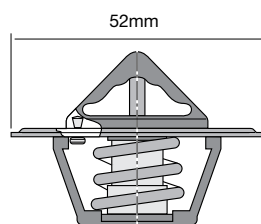

| |
|-----------------|
| Temp. Part No. |
| 71°C TT2001-160 |
| 82°C TT2001-180 |
| 88°C TT2001-190 |

TT2002 Series

Conventional style thermostat. High flow version of TT4 series.

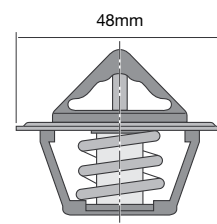

| |
|-----------------|
| Temp. Part No. |
| 82°C TT2002-180 |
| 89°C TT2002-192 |
| 91°C TT2002-195 |

TT2003 Series

Conventional style thermostat. High flow version of TT203 series.

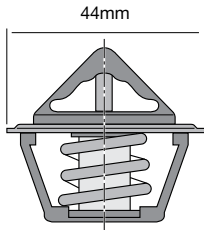

Temp. Part No.
82°C TT2003-180
91°C TT2003-195

TT2004 Series

Conventional style thermostat. High flow version of TT204 series.

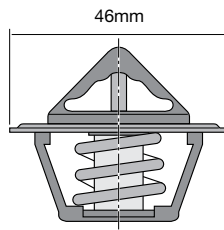

Temp. Part No.
79°C TT2004-174

TT2014 Series

Bypass style thermostat. High flow version of TT214 series.

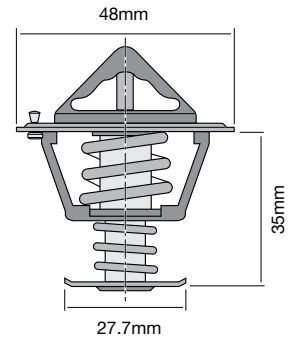

Temp. Part No.
60°C TT2014-140
77°C TT2014-170
82°C TT2014-180
89°C TT2014-192

TT2023 Series

Bypass style thermostat. Ford Cleveland V8 with jiggle pin.

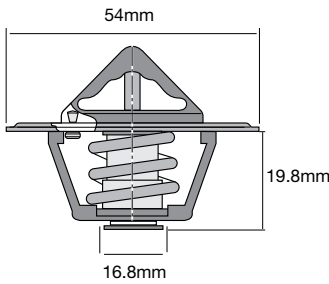

Temp. Part No.
77°C TT2023-170
82°C TT2023-180

TT2028 Series

Bypass style thermostat with jiggle pin. High flow version of TT228 series.

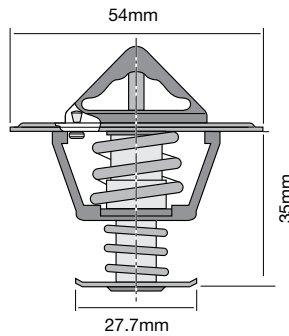

Temp. Part No.
77°C TT2028-170
82°C TT2028-180
91°C TT2028-195

TT2029 Series

Bypass style thermostat with jiggle pin. High flow version of TT229 series.

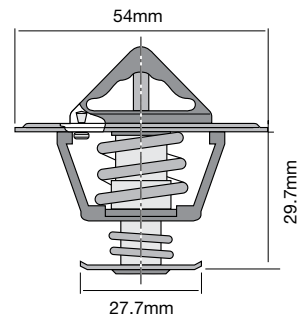

Temp. Part No.
60°C TT2029-140
71°C TT2029-160
82°C TT2029-180
91°C TT2029-195

TT2033 Series

Bypass style thermostat with jiggle pin. High flow version of TT233 series.

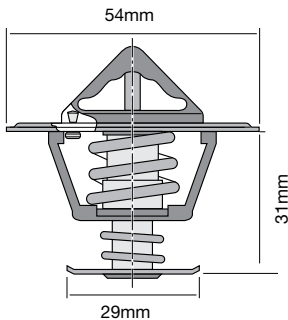

Temp. Part No.
77°C TT2033-170
82°C TT2033-180
89°C TT2033-192
91°C TT2033-195

TT2034 Series

Bypass style thermostat with jiggle pin. High flow version of TT234 series.

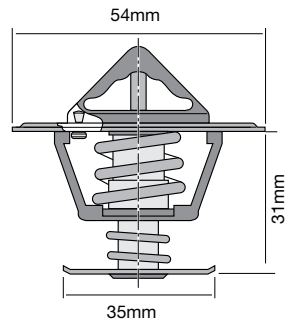

Temp. Part No.
82°C TT2034-180
89°C TT2034-192

TT2040 Series

Offset conventional style thermostat with jiggle pin. High flow version of TT240 series.

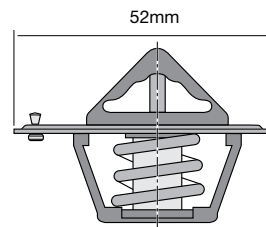

Temp. Part No.
82°C TT2040-180
89°C TT2040-192

TT2041 Series

Offset conventional style thermostat with jiggle pin. High flow version of TT241 series.

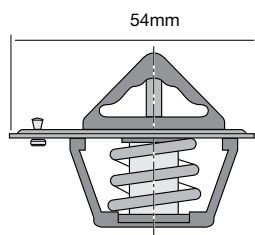

Temp. Part No.
 77°C TT2041-170
 82°C TT2041-180
 85°C TT2041-185
 88°C TT2041-190

TT2042 Series

Offset bypass style thermostat with jiggle pin. High flow version of TT242 series.

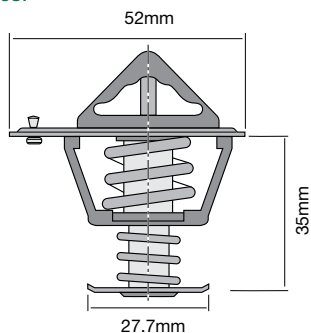

Temp. Part No.
 77°C TT2042-170
 82°C TT2042-180
 89°C TT2042-192

TT2065 Series

Bypass style thermostat with jiggle pin. High flow version of TT265 series.

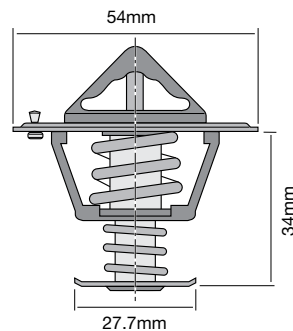

Temp. Part No.
 82°C TT2065-180
 89°C TT2065-192
 91°C TT2065-195

TT2322 Series

Bypass style thermostat with jiggle pin. High flow version of TT322 series.

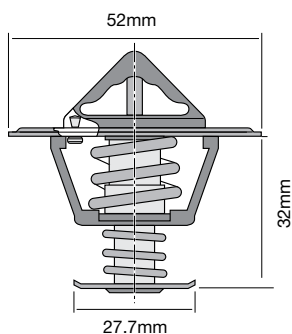

Temp. Part No.
 82°C TT2322-180
 89°C TT2322-192

TT8010 Series

Bypass style thermostat.

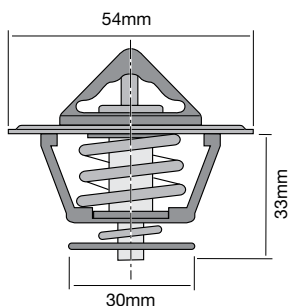

Temp. Part No.
 82°C TT8010-180P

TT8017 Series

Bypass style thermostat with double jiggle pin.

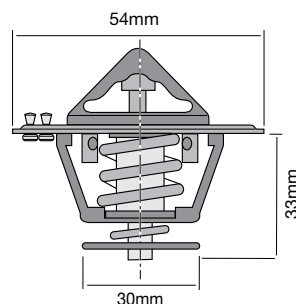

Temp. Part No.
 82°C TT8017-180P

TT8039 Series

Bypass style thermostat with jiggle pin.

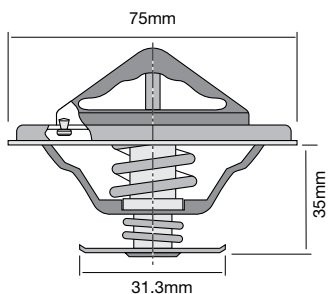

Temp. Part No.
 82°C TT8039-180P

TT8047 Series

Bypass style thermostat with inverse jiggle pin.

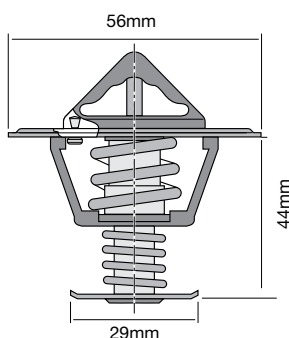

Temp. Part No.
 89°C TT8047-192P

TT8069 Series

Bypass style thermostat.

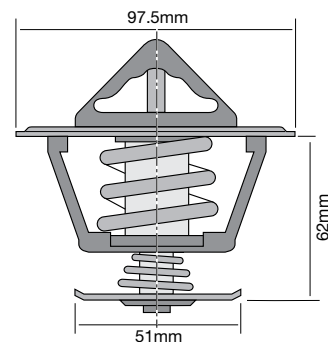

Temp. Part No.
 77°C TT8069-170P

Identification Guide

TT8073 Series

Bypass style thermostat with double jiggle pin.

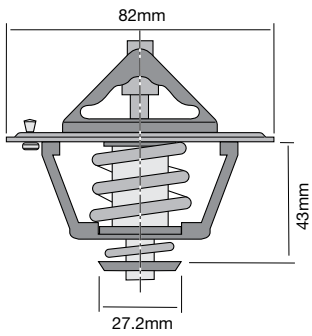

Temp. Part No.
77°C TT8073-170P
82°C TT8073-180P

TT8078 Series

Special design thermostat.

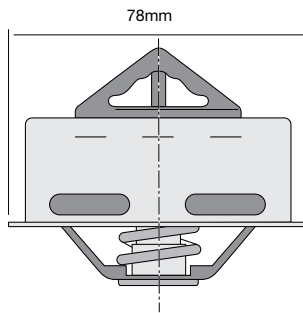

Temp. Part No.
77°C TT8078-170P

TT8085 Series

Bypass style thermostat.

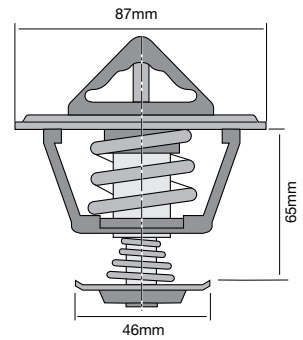

Temp. Part No.
77°C TT8085-170P

TT8090 Series

Bypass style thermostat, gasket included.

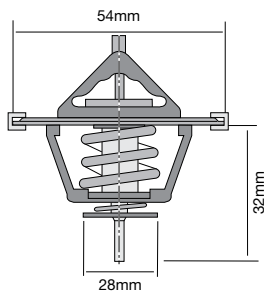

Temp. Part No.
82°C TT8090-180P

TT8700 Series

Special design thermostat.

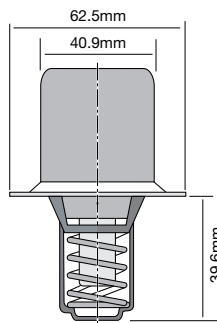

Temp. Part No.
71°C TT8700-160P
77°C TT8700-170P
82°C TT8700-180P
91°C TT8700-195P

TT8800 Series

Special design thermostat.

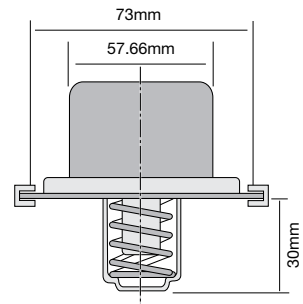

Temp. Part No.
71°C TT8800-160P
77°C TT8800-170P
82°C TT8800-180P
91°C TT8800-195P

Temperature Conversion

Fahrenheit Celsius

140 – 60
160 – 71
165 – 74
167 – 75
170 – 77
172 – 78
174 – 79

Fahrenheit Celsius

176 – 80
180 – 82
181 – 83
182 – 83
183 – 84
185 – 85
186 – 86

Fahrenheit Celsius

187 – 86
189 – 87
190 – 88
192 – 89
194 – 90
195 – 91
198 – 92

Fahrenheit Celsius

203 – 95
205 – 96
206 – 97
212 – 100
217 – 103
221 – 105
228 – 109

This section assists in identifying the range of Tridon thermostat gaskets. Drawings of each gasket part number (not to scale) show the diameter in millimetres and can be used for matching with your old gasket. Most paper style gaskets are adhesive backed for easy installation.

A comprehensive range of rubber ring gaskets (seals) is available to suit various vehicle applications. Certain thermostat part numbers are supplied complete with rubber 'O' ring seals. Information on thermostats supplied complete with 'O' ring are detailed in the thermostat application list. Refer to the vehicle application list for the recommended paper gasket or 'O' ring seal.

For packaging and merchandising details refer to page 4.

Thermostat Gaskets



Thermostat Gaskets



Function

The thermostat gasket is either a paper or moulded rubber ring used to seal the thermostat housing assembly to the cooling system.

Thermostat Gasket Styles

Two main types of thermostat gaskets are commonly used including **Paper Gaskets** and **Rubber Ring Gaskets** ('O' ring seal).

Paper Gaskets

Paper gaskets are manufactured from thermostat gasket paper material. The Tridon thermostat range consists of both application specific or universal paper gaskets. Tridon universal paper gaskets can be cut to suit an individual requirement. Some Tridon paper gaskets have an adhesive backing to assist with installation.

Rubber Ring Gaskets ('O' ring seal)

Rubber ring gaskets are manufactured to form moulded rubber profiles. The Tridon rubber gasket range consists of various rubber profiles and sizes designed to replace specific OEM applications. Refer to the Tridon vehicle application list for the correct application.

Some manufacturers do not use paper or rubber ring gaskets, rather liquid gasket sealant compounds. For applications where liquid gasket sealant compounds are recommended refer to manufacturer's specifications for the type required.

Some Tridon thermostats are sold with the thermostat gasket included. Refer to the vehicle application list or thermostat section for further information by part number. For these Tridon part numbers the thermostat gasket is not sold separately.

TTG1U

Self adhesive backed paper style gasket

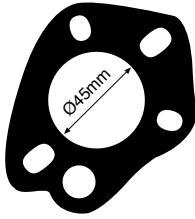

TTG2U

Self adhesive backed paper style gasket

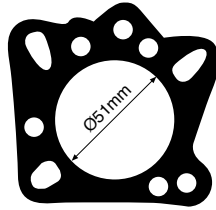

TTG3

Self adhesive backed paper style gasket

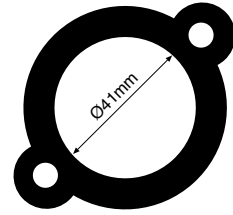

TTG4

Self adhesive backed paper style gasket

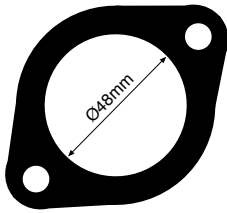

TTG5

Self adhesive backed paper style gasket

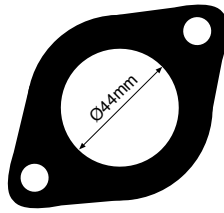

TTG6

Self adhesive backed paper style gasket

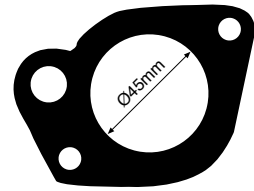

TTG7

Self adhesive backed paper style gasket



TTG8

Self adhesive backed paper style gasket

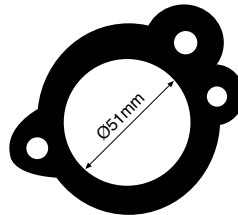

TTG9

Self adhesive backed paper style gasket

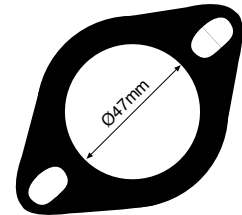

TTG10

Self adhesive backed paper style gasket

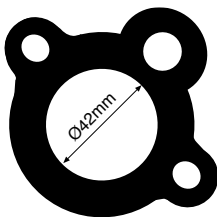

TTG11

Rubber seal gasket

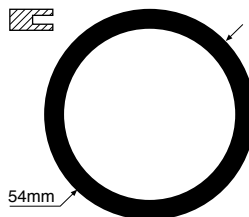

TTG12

Rubber seal gasket

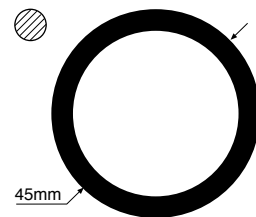

TTG13

Self adhesive backed paper style gasket

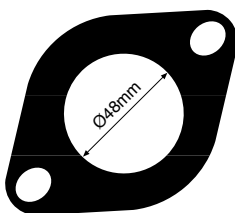

TTG14

Self adhesive backed paper style gasket

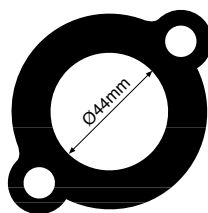

TTG15

Self adhesive backed paper style gasket

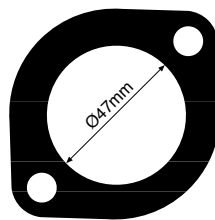

TTG16

Self adhesive backed paper style gasket

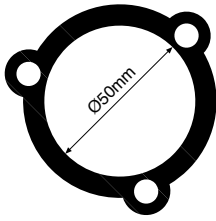

TTG17

Self adhesive backed paper style gasket

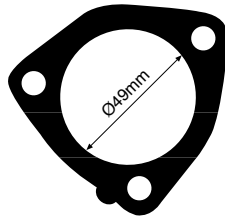

TTG18

Self adhesive backed paper style gasket

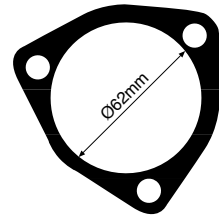

TTG19

Self adhesive backed paper style gasket

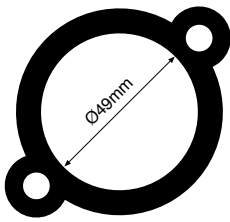

TTG20U

Self adhesive backed paper style gasket

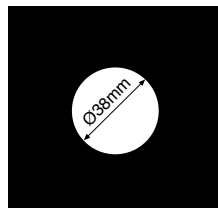

TTG21

Self adhesive backed paper style gasket

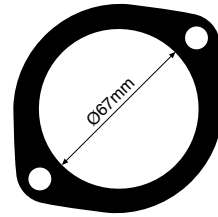

TTG22

Rubber seal gasket

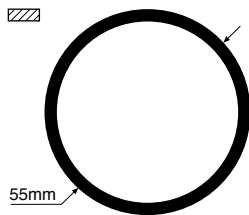

TTG23

Self adhesive backed paper style gasket

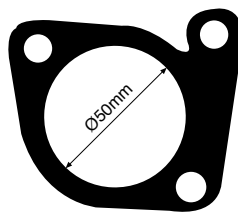

TTG24

Self adhesive backed paper style gasket



TTG25

Self adhesive backed paper style gasket

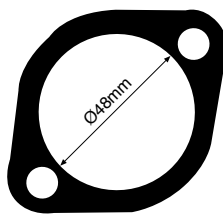

TTG26

Rubber seal gasket

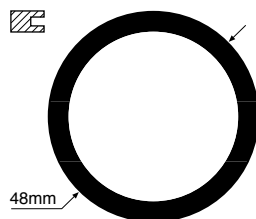

TTG27

Rubber seal gasket

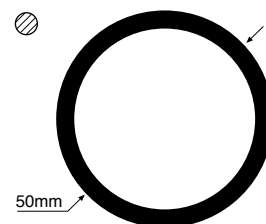

TTG28

Rubber seal gasket

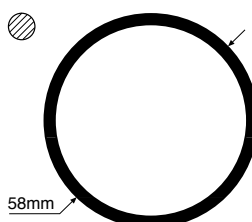

TTG29U

Self adhesive backed paper style gasket

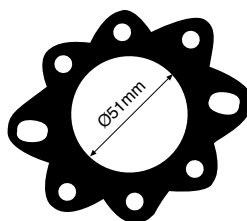

TTG30

Rubber seal gasket

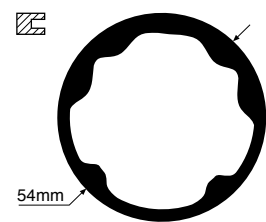

TTG31

Rubber seal gasket

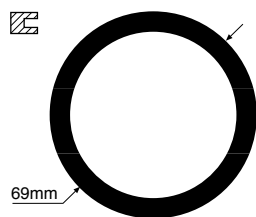

TTG32

Rubber seal gasket

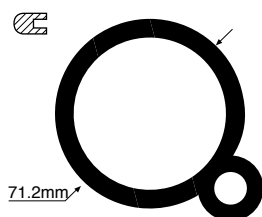

TTG33

Rubber seal gasket

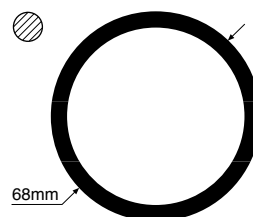

TTG34

Rubber seal gasket

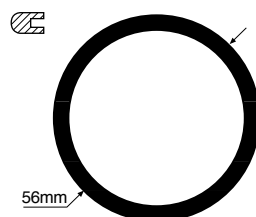

TTG35

Rubber seal gasket

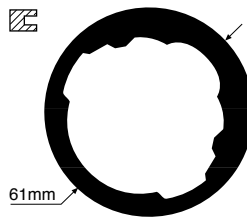

TTG36

Self adhesive backed paper style gasket

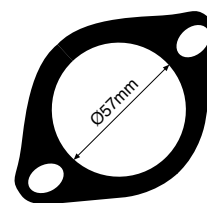

TTG37

Self adhesive backed paper style gasket

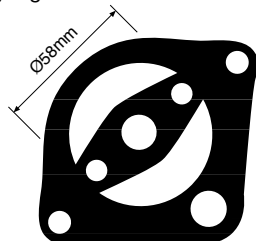

TTG38

Self adhesive backed paper style gasket

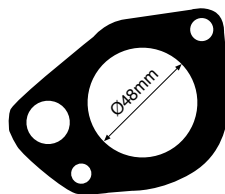

TTG39

Self adhesive backed paper style gasket

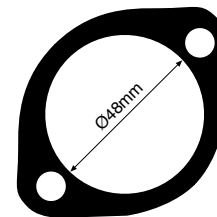

TTG40

Self adhesive backed paper style gasket

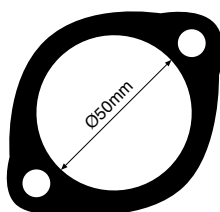

TTG41

Self adhesive backed paper style gasket

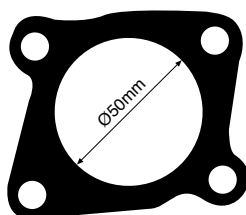

TTG42

Self adhesive backed paper style gasket

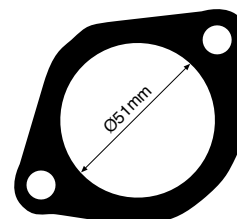

TTG43

Self adhesive backed paper style gasket

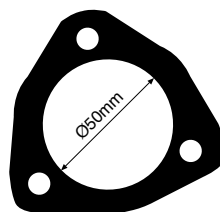

TTG44

Self adhesive backed paper style gasket

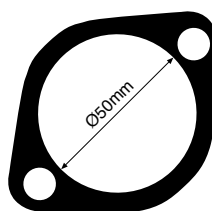

TTG45

Rubber seal gasket

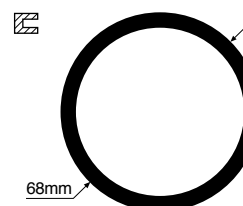

TTG46

Self adhesive backed
paper style gasket

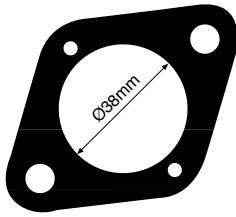

TTG47

Rubber seal gasket

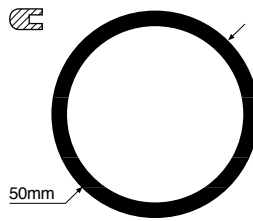

TTG48

Rubber seal gasket

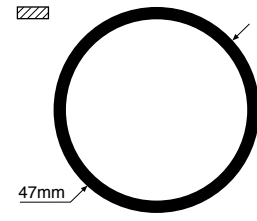

TTG49

Rubber seal gasket

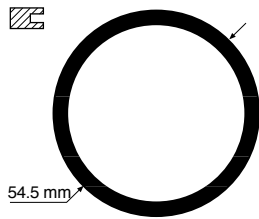

TTG50

Self adhesive backed
paper style gasket

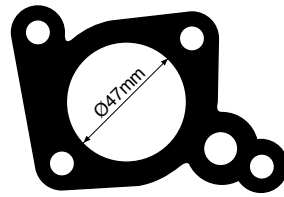

TTG51

Rubber seal gasket

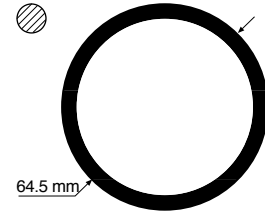

TTG55

Self adhesive backed
paper style gasket



TTG56

Self adhesive backed
paper style gasket

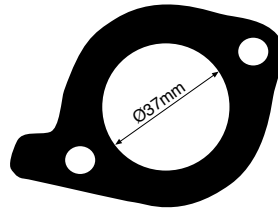

TTG57

Self adhesive backed
paper style gasket

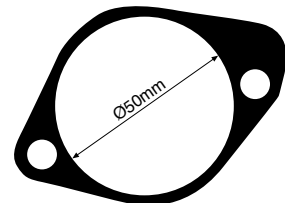

TTG58

Self adhesive backed
paper style gasket

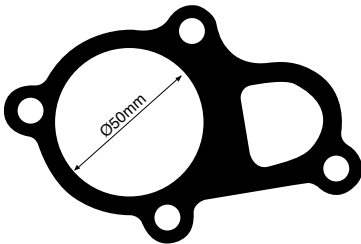

TTG59

Self adhesive backed
paper style gasket

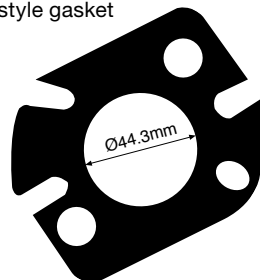

TTG60

Self adhesive backed
paper style gasket

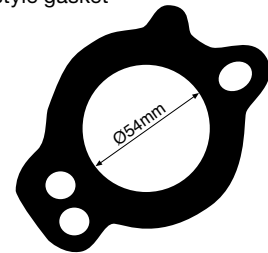

TTG61

Self adhesive backed
paper style gasket

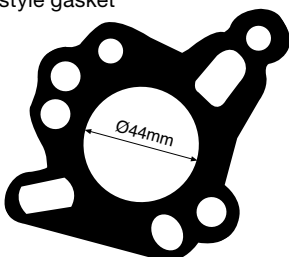

TTG62

Paper style gasket

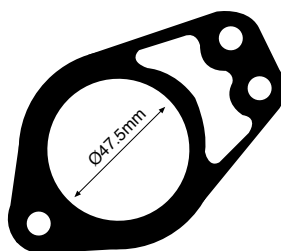

TTG63

Self adhesive backed
paper style gasket

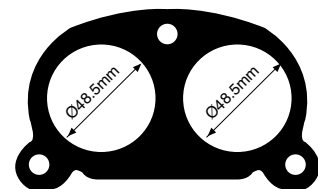

TTG64
Self adhesive backed
paper style gasket

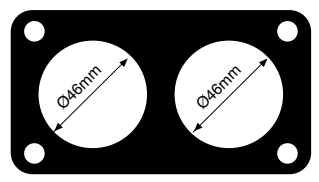

TTG65
Seal with metal outer
and rubber inner

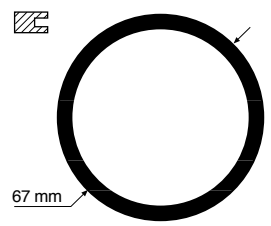

TTG68
Rubber seal gasket

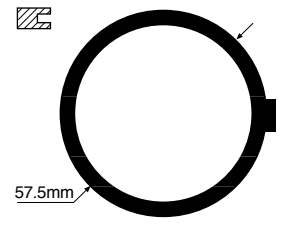

TTG69
Rubber seal gasket

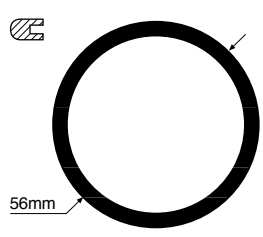

TTG70
Rubber seal gasket

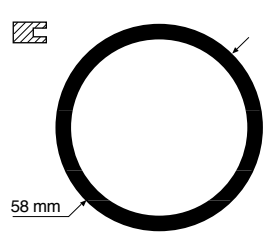

TTG71
Self adhesive backed
paper style gasket

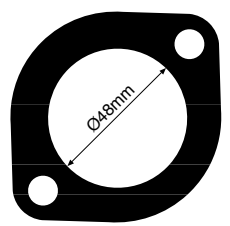

TTG72
Rubber seal gasket

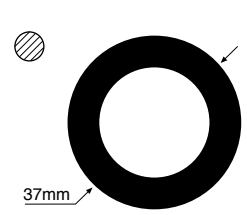

TTG73
Rubber seal gasket

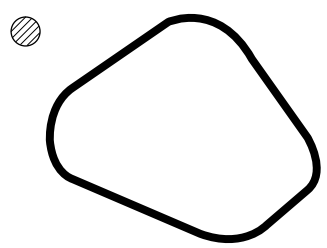

TTG74
Rubber seal gasket

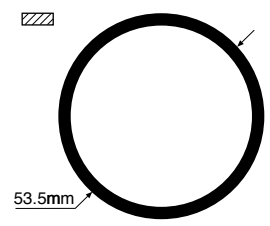

TTG75
Rubber seal gasket

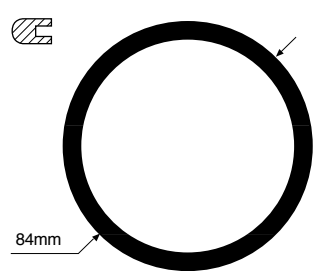

TTG76
Rubber seal gasket

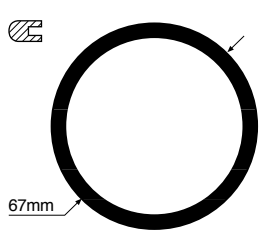

TTG77
Paper style gasket



electronic part finder

Additional vehicles and applications may have been introduced after the time of catalogue printing. For complete, up to date vehicle application listings refer to the Tridon website www.tridon.com.au (or www.tridon.co.nz) and go to **Tridon Part Finder**.

The Tridon Part Finder contains the most up to date vehicle information and parts applications. It is easy to use, just follow these steps to select the correct Tridon part:

Step 1: Go to www.tridon.com.au or www.tridon.co.nz

Step 2: Select Part Finder Tab

Step 3: Select Vehicle Make

Step 4: Select Vehicle Model

Step 5: Select Year

Step 6: Select the Series, Engine or Date

Step 7: Select the Tridon Part Required

TRIDON

CONTACT US | HOME

PRODUCTS | PART FINDER | ABOUT TRIDON | DOWNLOADS

SEARCH Go

Home » Part Finder

Part Finder

Select make
Holden

Select model
Commodore

Select year
All years

Select application(s)
 All Ignition Switches & Sensors Wiper
 Automotive Caps Hailory Squeezees Thermostats & Gaskets Tiring Tools
 Flashers & Relays

TT2003-195 Thermostat (High Flow)

Features

- Opening Temp: 91°C
- Flange Dia: 44mm
- Foot Dia: -
- Height: -
- Conventional style thermostat.
- High flow version of TT203 series.

Applications for Holden Commodore VY Series II, V6, 3.0L, OHV, Petrol, MPFI, RWD, 152, Eng code: LG3, 1/08/2003 - 1/07/2004

| Part No | Description | Location | Start Date | End Date | Comments |
|------------|----------------------------|-----------------------|------------|----------|---|
| TCAS287 | Cam Angle Sensor | In front timing cover | | | |
| TCAS14 | Crank Angle Sensor | On front timing cover | | | |
| FET13 | Electronic Flasher | | | | FET16 can be used if additional trailer dashboard indicator is required. |
| TF1226 | Fuel Cap (Locking) | | | | Not suitable for Ute |
| TF1227 | Fuel Cap (Locking) | | | | Suits Ute |
| TF16226 | Fuel Cap (Non Locking) | | | | Not suitable for Ute |
| TF16227 | Fuel Cap (Non Locking) | | | | Suits Ute |
| TC002 | Ignition Coil | | | | 3 required per vehicle |
| TC049 | Ignition module | | | | |
| TC0520 | Oil Cap | | | | |
| TO5000 | Oxygen Sensor (Direct Fit) | In front engine pipe | | | 3 Wire sensor |
| TO5012 | Oxygen Sensor (Universal) | | | | 2 Wire sensor |
| CA20135 | Radiator Cap | | | | |
| TT203-195 | Thermostat | | 08/2003 | 07/2004 | Conventional type thermostat, 44mm main flange. |
| TT2003-195 | Thermostat (High Flow) | | 08/2003 | 07/2004 | High flow thermostats allow approximately 20% more coolant flow than STD thermostats. |
| TT046 | Thermostat Gasket | | | | Paper style gasket. Sealing compound should be used. |
| TBL16 | Wiper Complete Blade | Rear Windscreen | | | |

For illustration purposes only. Please refer to Tridon website.