

100 YEARS

1920-2020

MANUFACTURING IN AUSTRALIA

CATALOGUE 43



Fallshaw
GROUP

**MOBILITY SOLUTIONS TO HELP YOU
PUSH, PULL & LIFT WITH EASE**

35% of all serious injuries are caused by pushing, pulling or lifting*

We can help you, and your staff, stay safe by providing solutions that eliminate manual materials handling from your workplace.

With our range of castors and materials handling equipment, a single operator can move up to 20 tonnes safely, without risk of back or shoulder strain. Furthermore, as a solutions provider, we can design and build everything to suit your particular workplace. This means that you, and your staff can do more with less—more productivity, less risk to injury.



We can help you

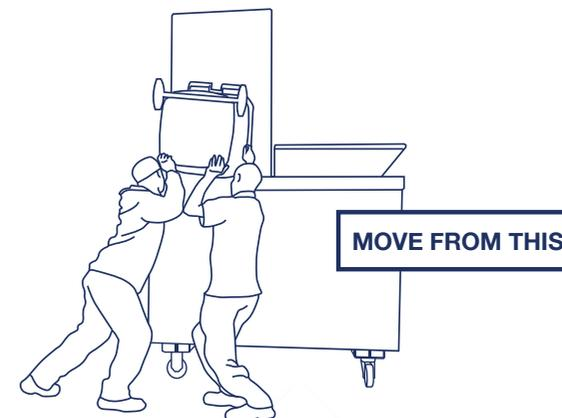

* Safe Work Australia 2014 statistics on worker's compensation claims.

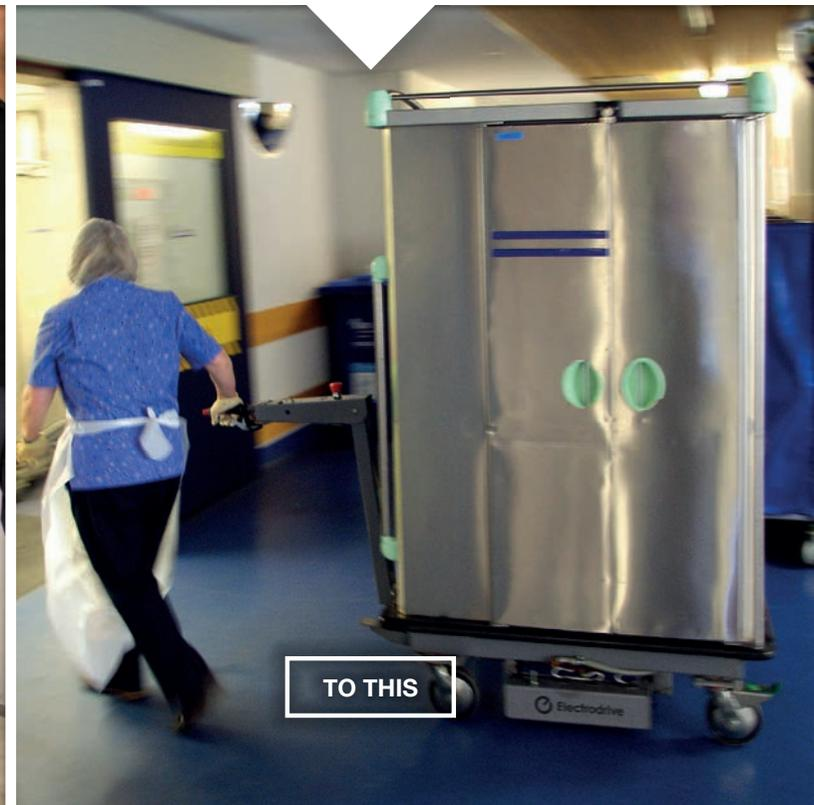
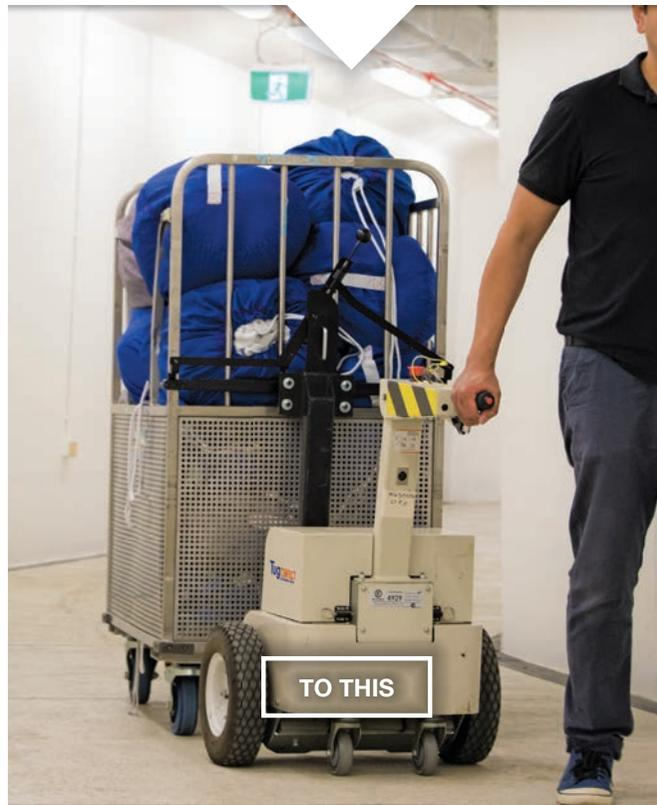
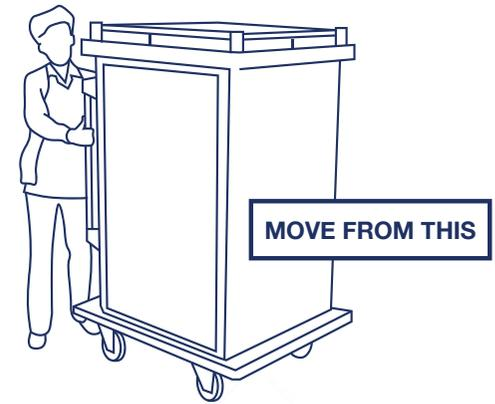
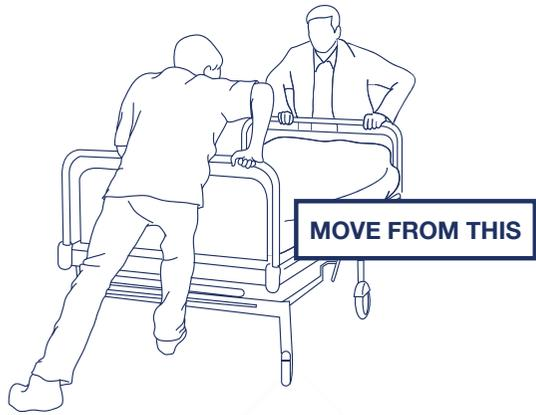



Wheels and castors

Overview	5
Choosing the right castor or wheel.....	6
Castor code structure	8
General castors	
Overview	9
Light to medium duty	
L Series (30 kg)	10
Twin Series (40 kg).....	11
N Series (90 kg).....	11
K Series (50–100 kg).....	12
M Series (85–200 kg).....	14
Big M Series (200 kg).....	17
General duty	
Y Series (50–360 kg).....	18
J Series (150–300 kg).....	20
Heavy duty	
O Series (230–500 kg).....	22
H Series (400–600 kg).....	24
H Series scaffold (360–500 kg).....	25
Very heavy duty	
W Series (500–750 kg).....	26
X Series (450–1000 kg).....	27
V Series (2000–2450 kg).....	28
A Series (3000–3500 kg).....	29

Decorative castors

Overview	30
Arc.....	31
Midnight Black.....	32
M Deluxe.....	33

Medical castors and wheels

Overview	34
Trinity series (including Trinity Electronic Braking Castors).....	35
Central locking castors	40
Conductive wheels.....	44
Wheelchair castors	45

Specialised castors

Overview	46
About chemical resistance.....	47
M Stainless.....	48
O Stainless.....	50
M Powder-coat	52
About high and low temperature castors.....	53
High & low temperature castors	54
Self-aligning castors	56
Supermarket trolley and travelator castors.....	58

Wheels

Overview	59
Soft wheels	60
Polyurethane	61
Hard wheels.....	62
Pneumatics and puncture-proof	63

Fittings and spares

Overview	67
----------------	----

Fittings

For 10 and 12 mm bolt hole castors	68
For 12 mm bolt hole castors	69
Installing expanding adaptors	70

Spares for pneumatics and general wheels

Tubes	71
Plastic rims	71
Bearings.....	71
Housing and reducing bushes.....	71
Tyres	71

General spares

Axles	72
Nuts and bolts	72
Spacers	72
Bearings and bushes.....	72
Grease nipples.....	72
Thread guards	73
Plates.....	73
Buffers	73



Powered mobility equipment

- Overview 75
- Choosing the right tug or mover 76
- Tugs 78
- Linen movers 80
- Meal delivery 81
- Tug hitching options 82
- Tub trolley mover 85
- Powered fifth wheel 86
- Patient movers 88
- Patient mover and linen mover hitches 90
- Bariatric wheelchair mover 91
- Trolley collection 92
- Wheelset mover 93



Waste handling solutions

- Overview 94
- How to choose the right bin lifter 96
- Full swing bin lifters 98
- Lift-and-tilt bin lifters 99
- Wheelie Bin Lid Opener and bins 100
- Bin movers 102
- Strong Arm hoist 103



Materials handling equipment

- Overview 105
- Gravity conveyors 106
- Lift tables 110
- Hospital bed maintenance lift 111
- Custom manufactured lift tables 112
- Pallet positioners 113
- Battery powered mobile scissor lifts 114
- Mobile scissor lifts 115
- Safety steps 117
- Pallet trucks 118
- Industrial trolleys 120
- Container skates 123
- Hand trucks 124
- Drum handling 125
- Follow-Me Trolley 126
- Adjustable feet 128
- Knock-in tube ends 129



Repairs, maintenance and fitting

- Overview 131
- What we do 132
- Preventative maintenance service plans 133



Fallshaw
GROUP

Mobility solutions to help you push, pull and lift with ease

- Our brands 134
- How it all began 136
- A history of innovation 137
- Core capabilities:
 - Avoiding collisions 138
 - Staying in front of the load 139
 - Your move-safe solution in healthcare 140
 - Site assessments and expert advice 141
 - Customised castors 142
 - Custom solutions specialists 144

Information and guides

- Overview 148
- Trading policies 149
- ISO9001 certification 149
- Conditions of use for castors 150
- Delivery policy 151
- Test summaries for wheels and castors 152
- Test summaries for materials handling equipment 154
- Maintenance and fitting 155
- Warranty 156
- Fork mount dimensions 157

100 YEARS

1920-2020

MANUFACTURING IN AUSTRALIA





Fallshaw

Wheels and castors

Proudly celebrating 100 years of manufacturing in Australia.

Spanning three generations of family, Fallshaw is an Australian manufacturing business who have proudly been designing and manufacturing high-quality wheels and castors in Australia for 100 years.

Our design philosophy is simple: We make castors that you can forget about! You won't have to worry about our castors, as they will perform every time. We back that up with a three year warranty on our Aussie-made wheels and castors.

We design our castors to steer true, give a smooth ride, require minimal push effort, and have brakes that work every time.

From castors for your office tables, to medical equipment, and all the way to heavy industrial applications, we make castors for a wide variety of load ratings, features, mount options and styles that seamlessly integrate with your furniture or equipment, across all industries.



Choosing the right castor or wheel

1 Choose the range based on what you are using it for and how much load it will carry

Light to medium duty

Load rating: 25–200 kg

(L, Twin, N, K, M and Big M)

Suitable for applications including:

- Trolleys and carts.
- Shop fittings and displays.
- Mobile storage.



General duty to heavy duty

Load rating: 200–600 kg

(J, Y O and H Series)

Suitable for applications including:

- Linen carts.
- Work platforms.
- Roll cages.
- Stock trolleys.



Very heavy duty

Load rating: 500–3500 kg

(W, X, V and A Series)

Suitable for applications including:

- Stock trolleys for automotive plants.
- Shipping containers.
- Multi-purpose industrial trolleys.



Medical

Load rating: 100–150 kg

(Trinity and Trinity EBC, Central locking, Wheelchair)

Medical equipment, hospital beds and other applications that need an automatic or accessible brake.

- Recliner chairs.
- Mobile computer tables.



2 Choose a wheel based on the floor surface it will be travelling on

Outdoors and rough ground

Bouncy, elastic tyres help get over bumps. That's why wheelbarrows and other applications that involve rough ground use pneumatic or rubber tyres.



Soft and smooth floors

Hard wheels have high load bearing capacity and reduce push effort on carpet and soft surfaces, but are very noisy on tiles and other hard surfaces and can also leave indentations on wooden floors.



Variable floor surfaces

Road cases are a classic example of tyres that need to adapt to a wide range of floor surfaces. When bands are on the move, their equipment needs to travel over bitumen, carpet, lino, wood and over curbs and stairs. These wheels go everywhere!



Specialised applications

Some applications have specific requirements, and we have a wide range of wheels to suit, including high and low temperature, wheelie bin wheels, central locking castors, antistatic wheels and many, many more!



3 Choose the wheel's diameter

The larger the wheel, the easier to push and the better the ride comfort (ability to pass over bumps and to minimize vibration).

Why? The larger the wheel, the smaller obstacles are in proportion to the wheel's diameter, resulting in greater momentum.

DIRECTION OF TRAVEL

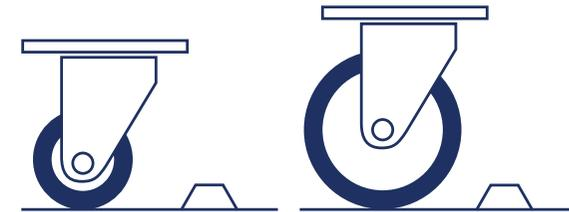

Wheel diameter should be maximised, bearing in mind that:

- As a rule of safety, mobile equipment should have a maximum height of 1400 mm (including the goods being carried) to enable a clear line of sight.
- Small wheels are sometimes used to reduce the centre of gravity to address tip hazards due to top-heavy loads.

4 Choose the bearing type

Precision industrial ball bearing

Used in applications where heat can build up due to friction caused by constant movement and/or higher speeds—all towing applications use precision bearings (as the high tolerance and hardened steel used in the sealed and greased bearings reduces heat build-up that can cause weakening of the wheel). Precision industrial ball bearings offer the lowest friction and therefore the lowest push effort—they are also the most expensive type of bearing in our range.



Deep groove cone ball bearing

Deep groove cone bearings are used in our outdoor, all-terrain wheels (such as pneumatics). They are designed to withstand rough, bumpy ground in applications where the direction of the load is both lateral and vertical (like wheelbarrows on construction sites).



Roller bearing

Used in high impact applications (the large surface area of the bearing spreads load and therefore protects against high impact). Not suitable for high speed (more than 6 km/h).



Plain bush (or bore)

Used in corrosive environments (polymer bearings won't rust). Also used to reduce cost (the cheapest kind of 'basic' bush).

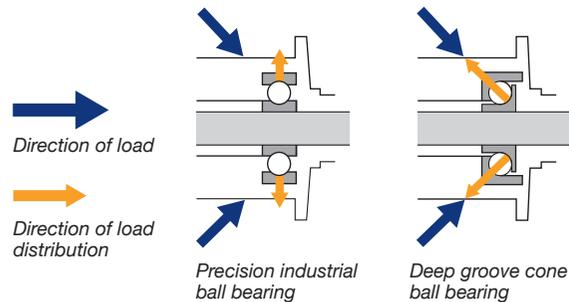

5 Choose the type of brake and castor configuration

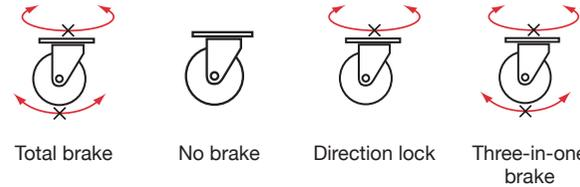

Castor configuration options

Traditional

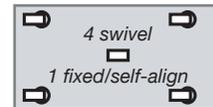

World's best practice

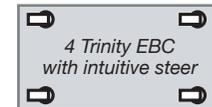

Trinity EBC with intuitive steer, automatically apply the steering device in the right direction, with the use of a motion sensor.



Trinity complete brake (CB) castors have a 3-in-1 brake that includes a direction lock option to steer from either end.

DIRECTION OF TRAVEL

6 Choose fittings

Bolt hole

Suitable for installing into tubular legs. We have a full range of expanding adaptors, pintle bolts, threaded tube ends, grip neck and friction stems and solid pintles, all designed to work seamlessly with any bolt hole castor.



Washer mount (for bolt hole)

Suitable for mounting bolt hole castors into equipment that do not have tubular legs.



Plate mount

Suitable for mounting onto equipment that have smooth flat surfaces, such as sheet metal or wood.



More information on fitting options can be found on pages 68–69.

Castor code structure

Wheel style	Tyre material	Bearing	Size (mm)	Extras	Fork series	Fork finish	Mount option	Brake option	Colourway/ Castor finish
Light duty L N	Soft tyres S Grey rubber (flat profile)	Precision industrial ball bearings Q Mild steel	40 50 65	G Thread guard	Light duty L N	Z Zinc plated Core Coat™ (with lacquer)	Plates P Swivel plate (ISO)	Core range TB Total brake (locks castor swivelling and wheel rotation)	Arc range GH Graphite SL Silver WT White GY Grey
Medium duty K M (C/Q/S)*	T Grey rubber (round profile) J Thermoplastic elastomer (TPE)	C Stainless steel	75 100 125	S Stainless steel axle bush	Medium duty K M	S Stainless steel P Powder-coated	PN Swivel plate (North American) F Fixed plate (ISO)	DL Direction lock (locks castor swivelling, but wheel can still rotate)	Midnight Black range BLK Black
General duty Y J	B Blue high resilience rubber R Black rubber	B Mild steel	150 175 200 220	GT Hub cap on twin wheel	General duty Y J	C Chrome N Nylon	FN Fixed plate (North American) Bolt hole H Swivel bolt hole	BR Wheel brake only	M Deluxe range BN Bluestone
Heavy duty O H	F Foamed microcellular Hard tyres	R Mild steel	250 265 400		Heavy duty O H	K Nickel	Stems/pintles L Long pintle S Short pintle 3B 3/8" pintle E 12 mm pintle GN Grip neck pintle J Friction stem	Specialised SA Self-aligning AGV kit on swivel fork TBSA Self-aligning AGV kit on TB fork	K & M Series R Red G Grey B Black
Very heavy duty W X V A	N Nylon U Polyurethane V PVC C Cast iron	A Inserted PBT bush			Very heavy duty W X V A			Medical CB Complete brake (3 position brake including swivel, TB and DL)*	High & Low Temperature HT High temp LT Low temp
Medical and specialised F C S	X High impact polymer Specialised A Conductive TPE H High temp nylon K High temp phenolic	N Nylon bore I Cast iron bore H High temp nylon bore P Polypropylene bore T High temp phenolic bore			Medical and specialised F C S				

* M, Central Locking and Supermarket series have multiple wheel styles of the same tyre material, so the wheel series have multiple designators to differentiate styles.

EXAMPLE:

J	B	R	125	G /	J	Z	P	TB	—
----------	----------	----------	------------	------------	----------	----------	----------	-----------	----------

Castor = wheel / fork

EXAMPLE: JBR125G/JZPTB

Note: The following castor series have a different code structure:

- Twin Wheel castors (see page 11).
- Y series castors (see page 18).
- Trinity Castors and Trinity Electronic Braking Castors (see page 39).



General castors

Light to medium duty castors

- L Series, Twin Series, N Series, K Series, M Series and Big M Series.

General to heavy duty castors

- Y Series, J Series, O Series and H Series.

Very heavy duty castors

- W Series, X Series, V Series and A Series.

L Series 30 kg



Features

- Thermoplastic elastomer (TPE) or hard nylon wheels.
- Nickel coated forks.
- Suitable for furniture and light duty trolleys.
- Bolt hole pintle sold separately (see page 68).
- Bolt hole castors supplied with axle bolt and nut. (Plate mounts are riveted.)



Wheels



LJP
TPE, plain bearing



LNN
Hard nylon, plain bearing

Forks



LKP
Plate with swivel



LKPBR
Plate with swivel and wheel brake



LKF
Fixed plate, no swivel



LKH
Bolt hole swivel



LKHBR
Bolt hole swivel and wheel brake

Specifications

Wheel	Max load (kg)	Diameter x tread (mm)	Hub x bore (mm)
LJP50	30	50 x 20	25 x 6
LNN50	30	50 x 20	25 x 6

Forks	Wheel size (mm)	Mount height (mm)	Turning radius (mm)
LKP/LKH/LKF*	50	65	47
LKPBR	50	65	60
LKHBR	50	65	67

Castor mount options (mm)

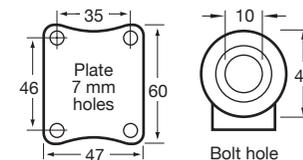

Order codes

Wheel	Castor
LJP50	LJP50/LKP
	LJP50/LKPBR
	LJP50/LKF
	LJP50/LKH
	LJP50/LKHBR
LNN50	LNN50/LKP
	LNN50/LKPBR
	LNN50/LKF
	LNN50/LKH
	LNN50/LKHBR

Grip neck pintle



For L series, M10 grip-neck pintles are supplied loose to be retro-fitted. Pintle size: 8 mm OD x 39 mm long (see page 68).

Order code

SP-GN

* LKF—fixed plate has no turning radius.

Twin Series 40 kg



Features

- Twin wheel plastic castors with or without wheel brake.
- Suitable for office chairs and light domestic furniture such as laundry baskets.

Castors



TW50P
Plate with swivel



TW50PBR
Plate with swivel and wheel brake



TW5038
Threaded 3/8" BSW pintle



TW5038BR
Threaded 3/8" BSW pintle with wheel brake



TW50CJ
Friction stem
(Suits most standard office chairs)

Order codes and specifications

Castor code	Diameter (mm)	Height (mm)	Turning radius (mm)	Max load (kg)
TW50P	50	61	46	40
TW50PBR	50	61	60	40
TW5038	50	61	46	40
TW5038BR	50	61	60	40
TW50CJ	50	61	46	40

Castor mount options (mm)

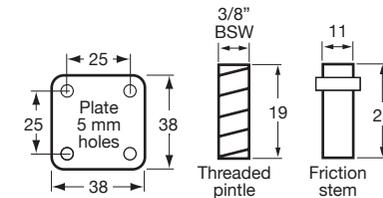

N Series 90 kg



Features

- White nylon wheels in zinc plated forks, Chicago screw axles, with or without wheel brake.
- Ultra-low mount height for heavy furniture and refrigerators.

Please note: Wheels are not available for separate purchase.

Castors



NNN40/NZP
Plate with swivel



NNN40/NZPBR
Plate with swivel and wheel brake

Order codes and specifications

Castor code	Max load (kg)	Diameter x tread (mm)	Hub x bore (mm)	Mount height (mm)	Turning radius (mm)
NNN40/NZP	90	40 x 44	53 x 6	62	40
NNN40/NZPBR	90	40 x 44	53 x 6	62	71

Castor mount (mm)

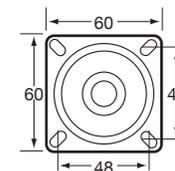

K Series 50–100 kg



Features

- Thermoplastic elastomer (TPE), grey rubber, hard nylon or polyurethane (PU) wheels.
- Swivel, fixed plate and bolt hole zinc plated Core Coat™ forks with or without total brake. Core Coat™ lacquer provides best quality corrosion protection, with no white or red rust after 150 hours of salt spray testing.
- Available with Chicago screw axles and alternate colourways.
- Made in Australia.

Wheels



KJQ*

TPE, precision bearing, thread guard

KSA

Grey rubber, plain bearing, optional thread guard¹

KNN

Hard nylon, plain bearing

KUQ*

PU, precision bearing, optional thread guard¹

Wheel	Max load (kg)	Diameter x tread (mm)	Hub x bore (mm)	Bore—no bush (mm)
KJQ65G	50	65 x 23	30 x 8	8
KJQ75G	50	75 x 23	30 x 8	8
KJQ100G	50	100 x 23	30 x 8	8
KSA65	50	65 x 23	30 x 8	12
KSA75	50	75 x 23	30 x 8	12
KSA100	50	100 x 23	30 x 8	12
KNN65	50	65 x 23	30 x 8	12
KNN75	65	75 x 23	30 x 8	12
KNN100	70	100 x 23	30 x 8	12
KUQ75	100	75 x 23	30 x 8	8
KUQ100	100	100 x 23	30 x 8	8

* Wheels also available with plain bearings—KJA, KUA.

Note that plain bearing bore is 12 mm.

¹ For optional thread guards, add **G** to the end of wheel code.

Forks



KZP

Plate with swivel

KZPTB

Plate with swivel and total brake

KZF

Fixed plate, no swivel

KZH

Bolt hole swivel

KZHTB

Bolt hole swivel and total brake

Fork	Wheel size (mm)	Mount height (mm)	Turning radius (mm)
KZP/KZH/KZF ²	65	96	63
	75	104	69
	100	131	82
KZPTB/KZHTB	65	96	89
	75	104	89
	100	131	89

Fork mounts

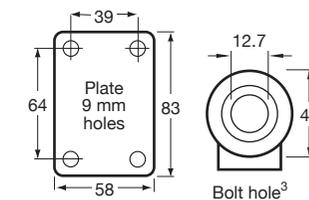

² KZF—fixed plate has no turning radius.

³ Bushes available to reduce bolt hole in round swivel race castors to 8 and 10 mm (see page 69).

Grip-neck pintles also available (see page 68).

Colourway and axle options

Colourways



Standard

Default castor colourway

Red

Add **R** to castor code
Example:
KJQ65G/KZPTBR

Grey

Add **G** to castor code
Example:
KJQ65G/KZPTBG

Chicago screw axle (optional)



To upgrade to a Chicago screw axle, add **C** to the end of castor code (after any colourway options)

Example:
KJQ65G/KZPTBRC

Order codes

Wheel	Fork	Castor
KJQ65G	K65ZP	KJQ65G/KZP
	K65ZPTB	KJQ65G/KZPTB
	K65ZF	KJQ65G/KZF
	K65ZH	KJQ65G/KZH
	K65ZHTB	KJQ65G/KZHTB
KJQ75G	K75ZP	KJQ75G/KZP
	K75ZPTB	KJQ75G/KZPTB
	K75ZF	KJQ75G/KZF
	K75ZH	KJQ75G/KZH
	K75ZHTB	KJQ75G/KZHTB
KJQ100G	K100ZP	KJQ100G/KZP
	K100ZPTB	KJQ100G/KZPTB
	K100ZF	KJQ100G/KZF
	K100ZH	KJQ100G/KZH
	K100ZHTB	KJQ100G/KZHTB
KSA65	K65ZP	KSA65/KZP
	K65ZPTB	KSA65/KZPTB
	K65ZF	KSA65/KZF
	K65ZH	KSA65/KZH
	K65ZHTB	KSA65/KZHTB
KSA75	K75ZP	KSA75/KZP
	K75ZPTB	KSA75/KZPTB
	K75ZF	KSA75/KZF
	K75ZH	KSA75/KZH
	K75ZHTB	KSA75/KZHTB
KSA100	K100ZP	KSA100/KZP
	K100ZPTB	KSA100/KZPTB
	K100ZF	KSA100/KZF
	K100ZH	KSA100/KZH
	K100ZHTB	KSA100/KZHTB

Wheel	Fork	Castor
KNN65	K65ZP	KNN65/KZP
	K65ZPTB	KNN65/KZPTB
	K65ZF	KNN65/KZF
	K65ZH	KNN65/KZH
	K65ZHTB	KNN65/KZHTB
KNN75	K75ZP	KNN75/KZP
	K75ZPTB	KNN75/KZPTB
	K75ZF	KNN75/KZF
	K75ZH	KNN75/KZH
	K75ZHTB	KNN75/KZHTB
KNN100	K100ZP	KNN100/KZP
	K100ZPTB	KNN100/KZPTB
	K100ZF	KNN100/KZF
	K100ZH	KNN100/KZH
	K100ZHTB	KNN100/KZHTB
KUQ75	K75ZP	KUQ75/KZP
	K75ZPTB	KUQ75/KZPTB
	K75ZF	KUQ75/KZF
	K75ZH	KUQ75/KZH
	K75ZHTB	KUQ75/KZHTB
KUQ100	K100ZP	KUQ100/KZP
	K100ZPTB	KUQ100/KZPTB
	K100ZF	KUQ100/KZF
	K100ZH	KUQ100/KZH
	K100ZHTB	KUQ100/KZHTB

M Series 85–200 kg



Wheels



MJQ*
TPE, precision bearing, thread guard



STQ
Grey rubber, round profile, precision bearing, thread guard



MSQ¹
Grey rubber, flat profile, precision bearing, thread guard



CBQ
Blue hi-res rubber, precision bearing, thread guard



MBQ
Blue hi-res rubber, precision bearing, thread guard



MNN²
Hard nylon, plain bearing



DNQ³
Hard nylon, precision bearing



QUQ¹
PU, precision bearing, thread guard

Forks



MZP
Plate with swivel



MZPTB
Plate with swivel and total brake



MZPDL
Plate with swivel and direction lock



MZF
Fixed plate, no swivel



MZH
Bolt hole swivel



MZHTB
Bolt hole swivel and total brake



MZHDL
Bolt hole swivel and direction lock

Features

- Thermoplastic elastomer (TPE), blue high resilience (hi-res) rubber, grey rubber, polyurethane (PU) or hard nylon wheels.
- Swivel, fixed plate and bolt hole zinc plated Core Coat™ forks with or without total brake or direction lock. Core Coat™ lacquer provides best quality corrosion protection, with no white or red rust after 150 hours of salt spray testing.
- Available with Chicago screw axles and alternate colourways.
- Made in Australia.

Wheel	Max load (kg)	Diameter x tread (mm)	Hub x bore (mm)	Bore—no bush (mm)
MJQ75G	85	75 x 32	40 x 8	8
MJQ100G	85	100 x 32	40 x 8	8
MJQ125G	85	125 x 32	40 x 8	8
STQ75G	100	75 x 32	40 x 8	8
STQ100G	100	100 x 32	40 x 8	8
STQ125G	100	125 x 32	40 x 8	8
MSQ100G	140	100 x 34	40 x 8	8
MSQ125G	150	125 x 34	40 x 8	8
CBQ75G	85	75 x 33	40 x 8	8
CBQ100G	100	100 x 33	40 x 8	8
CBQ125G	100	125 x 33	40 x 8	8

Wheel	Max load (kg)	Diameter x tread (mm)	Hub x bore (mm)	Bore—no bush (mm)
MBQ100G	140	100 x 36	40 x 8	8
MBQ125G	150	125 x 36	40 x 8	8
MNN75	150	75 x 32	40 x 8	12
MNN100	150	100 x 32	40 x 8	12
MNN125	150	125 x 32	40 x 8	12
DNQ100 ³	200	100 x 32	40 x 8	8
DNQ125	200	125 x 32	40 x 8	8
QUQ75G	200	75 x 32	40 x 8	8
QUQ100G	200	100 x 32	40 x 8	8
QUQ125G	200	125 x 32	40 x 8	8

Fork	Wheel size (mm)	Mount height (mm)	Turning radius (mm)
MZP/MZH/MZF ⁴	75	106	71
	100	135	91
	125	161	103
MZPTB/MZPDL/ MZHTB/ MZHDL	75	106	118
	100	135	128
	125	161	128

Fork mounts

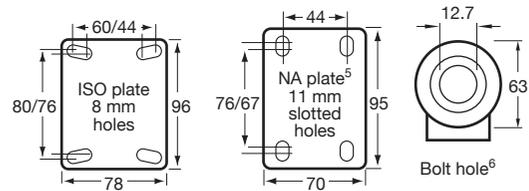

Colourway and axle options

Colourway



Standard

Default castor colourway

Black

Add **B** to castor code
Example:
CBQ75G/MZPTBB

Grey

Add **G** to castor code
Example:
CBQ75G/MZPTBG

Chicago screw axle (optional)



To upgrade to a Chicago screw axle, add **C** to the end of castor code (after any colourway options)

Example:
CBQ75G/MZPTBBC

Order codes

Wheel	Fork	Castor	Wheel	Fork	Castor	
CBQ75G	M75ZP	CBQ75G/MZP	MBQ125G	M125ZP	MBQ125G/MZP	
	M75ZPTB	CBQ75G/MZPTB		M125ZPTB	MBQ125G/MZPTB	
	M75ZPDL	CBQ75G/MZPDL		M125ZPDL	MBQ125G/MZPDL	
	M75ZF	CBQ75G/MZF		M125ZF	MBQ125G/MZF	
	M75ZH	CBQ75G/MZH		M125ZH	MBQ125G/MZH	
	M75ZHTB	CBQ75G/MZHTB		M125ZHTB	MBQ125G/MZHTB	
	M75ZHDL	CBQ75G/MZHDL		M125ZHDL	MBQ125G/MZHDL	
CBQ100G	M100ZP	CBQ100G/MZP	MJQ75G	M75ZP	MJQ75G/MZP	
	M100ZPTB	CBQ100G/MZPTB		M75ZPTB	MJQ75G/MZPTB	
	M100ZPDL	CBQ100G/MZPDL		M75ZPDL	MJQ75G/MZPDL	
	M100ZF	CBQ100G/MZF		M75ZF	MJQ75G/MZF	
	M100ZH	CBQ100G/MZH		M75ZH	MJQ75G/MZH	
	M100ZHTB	CBQ100G/MZHTB		M75ZHTB	MJQ75G/MZHTB	
	M100ZHDL	CBQ100G/MZHDL		M75ZHDL	MJQ75G/MZHDL	
CBQ125G	M125ZP	CBQ125G/MZP	MJQ100G	M100ZP	MJQ100G/MZP	
	M125ZPTB	CBQ125G/MZPTB		M100ZPTB	MJQ100G/MZPTB	
	M125ZPDL	CBQ125G/MZPDL		M100ZPDL	MJQ100G/MZPDL	
	M125ZF	CBQ125G/MZF		M100ZF	MJQ100G/MZF	
	M125ZH	CBQ125G/MZH		M100ZH	MJQ100G/MZH	
	M125ZHTB	CBQ125G/MZHTB		M100ZHTB	MJQ100G/MZHTB	
	M125ZHDL	CBQ125G/MZHDL		M100ZHDL	MJQ100G/MZHDL	
DNQ125	M125ZP	DNQ125/MZP	MJQ125G	M125ZP	MJQ125G/MZP	
	M125ZPTB	DNQ125/MZPTB		M125ZPTB	MJQ125G/MZPTB	
	M125ZPDL	DNQ125/MZPDL		M125ZPDL	MJQ125G/MZPDL	
	M125ZF	DNQ125/MZF		M125ZF	MJQ125G/MZF	
	M125ZH	DNQ125/MZH		M125ZH	MJQ125G/MZH	
	M125ZHTB	DNQ125/MZHTB		M125ZHTB	MJQ125G/MZHTB	
	M125ZHDL	DNQ125/MZHDL		M125ZHDL	MJQ125G/MZHDL	
MBQ100G	M100ZP	MBQ100G/MZP	* MJQ also available in conductive—MAQ, or plain bearing—MJA.			
	M100ZPTB	MBQ100G/MZPTB		¹ Wheels also available with plain bearing—MSA, QUA.		
	M100ZPDL	MBQ100G/MZPDL		² MNN also available in white—MNN...W.		
	M100ZF	MBQ100G/MZF		³ DNQ also available in white—DNQ125W. DNQ100 and DNQ100W are made to order.		
	M100ZH	MBQ100G/MZH		⁴ MZF—fixed plate has no turning radius.		
	M100ZHTB	MBQ100G/MZHTB		⁵ North American plate. Add N to the end of fork code to purchase (eg. CBQ75G/MZPNTB).		
	M100ZHDL	MBQ100G/MZHDL		⁶ Bushes available to reduce bolt hole to 8 and 10 mm (see page 69). Grip-neck pintles also available (see page 68).		

Wheel	Fork	Castor	Wheel	Fork	Castor	Wheel	Fork	Castor
MNN75	M75ZP	MNN75/MZP	QUQ75G	M75ZP	QUQ75G/MZP	STQ75G	M75ZP	STQ75G/MZP
	M75ZPTB	MNN75/MZPTB		M75ZPTB	QUQ75G/MZPTB		M75ZPTB	STQ75G/MZPTB
	M75ZPDL	MNN75/MZPDL		M75ZPDL	QUQ75G/MZPDL		M75ZPDL	STQ75G/MZPDL
	M75ZF	MNN75/MZF		M75ZF	QUQ75G/MZF		M75ZF	STQ75G/MZF
	M75ZH	MNN75/MZH		M75ZH	QUQ75G/MZH		M75ZH	STQ75G/MZH
	M75ZHTB	MNN75/MZHTB		M75ZHTB	QUQ75G/MZHTB		M75ZHTB	STQ75G/MZHTB
	M75ZHDL	MNN75/MZHDL		M75ZHDL	QUQ75G/MZHDL		M75ZHDL	STQ75G/MZHDL
MNN100	M100ZP	MNN100/MZP	QUQ100G	M100ZP	QUQ100G/MZP	STQ100G	M100ZP	STQ100G/MZP
	M100ZPTB	MNN100/MZPTB		M100ZPTB	QUQ100G/MZPTB		M100ZPTB	STQ100G/MZPTB
	M100ZPDL	MNN100/MZPDL		M100ZPDL	QUQ100G/MZPDL		M100ZPDL	STQ100G/MZPDL
	M100ZF	MNN100/MZF		M100ZF	QUQ100G/MZF		M100ZF	STQ100G/MZF
	M100ZH	MNN100/MZH		M100ZH	QUQ100G/MZH		M100ZH	STQ100G/MZH
	M100ZHTB	MNN100/MZHTB		M100ZHTB	QUQ100G/MZHTB		M100ZHTB	STQ100G/MZHTB
	M100ZHDL	MNN100/MZHDL		M100ZHDL	QUQ100G/MZHDL		M100ZHDL	STQ100G/MZHDL
MNN125	M125ZP	MNN125/MZP	QUQ125G	M125ZP	QUQ125G/MZP	STQ125G	M125ZP	STQ125G/MZP
	M125ZPTB	MNN125/MZPTB		M125ZPTB	QUQ125G/MZPTB		M125ZPTB	STQ125G/MZPTB
	M125ZPDL	MNN125/MZPDL		M125ZPDL	QUQ125G/MZPDL		M125ZPDL	STQ125G/MZPDL
	M125ZF	MNN125/MZF		M125ZF	QUQ125G/MZF		M125ZF	STQ125G/MZF
	M125ZH	MNN125/MZH		M125ZH	QUQ125G/MZH		M125ZH	STQ125G/MZH
	M125ZHTB	MNN125/MZHTB		M125ZHTB	QUQ125G/MZHTB		M125ZHTB	STQ125G/MZHTB
	M125ZHDL	MNN125/MZHDL		M125ZHDL	QUQ125G/MZHDL		M125ZHDL	STQ125G/MZHDL
MSQ100G	M100ZP	MSQ100G/MZP						
	M100ZPTB	MSQ100G/MZPTB						
	M100ZPDL	MSQ100G/MZPDL						
	M100ZF	MSQ100G/MZF						
	M100ZH	MSQ100G/MZH						
	M100ZHTB	MSQ100G/MZHTB						
	M100ZHDL	MSQ100G/MZHDL						
MSQ125G	M125ZP	MSQ125G/MZP						
	M125ZPTB	MSQ125G/MZPTB						
	M125ZPDL	MSQ125G/MZPDL						
	M125ZF	MSQ125G/MZF						
	M125ZH	MSQ125G/MZH						
	M125ZHTB	MSQ125G/MZHTB						
	M125ZHDL	MSQ125G/MZHDL						

Big M Series 200 kg



- Grey rubber wheel with round profile, precision bearing and thread guard (plain bearing wheel also available).
- Swivel, fixed plate and bolt hole zinc plated Core Coat™ forks with total brake or direction lock. Core Coat™ lacquer provides best quality corrosion protection, with no white or red rust after 150 hours of salt spray testing.
- Available with Chicago screw axles and alternate colourways.
- Made in Australia.

Castor options

			
QTQ wheel* Grey rubber, round profile, precision bearing, thread guard	MZP Plate with swivel	MZPTB Plate with swivel and total brake	MZPDL Plate with swivel and direction lock
			
MZFN North American fixed plate (150 mm only)	MZH Bolt hole swivel	MZHTB Bolt hole swivel and total brake	MZHDL Bolt hole swivel and direction lock

Wheel	Max load (kg)	Diameter x tread (mm)	Hub x bore (mm)
QTQ150G	200	150 x 34	40 x 8
QTQ175G	200	175 x 34	40 x 8

Fork	Wheel size (mm)	Mount height (mm)	Turning radius (mm)
MZP/MZH/	150	187	130
	175	214	145
MZFN	150	187	-
MZPTB/MZPDL	150	187	153
MZHTB/MZHDL	175	214	153

Fork mounts

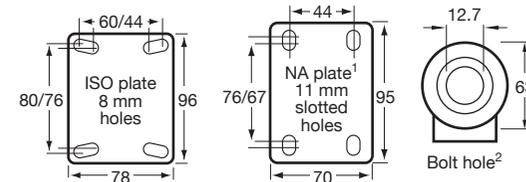

Colourway and axle options

Colourway

		
Standard Default castor colourway	Black Add B to castor code <i>Example:</i> QTQ150G/MZPTBB	Grey Add G to castor code <i>Example:</i> QTQ150G/MZPTBG

Chicago screw axle (optional)



To upgrade to a Chicago screw axle, add **C** to the end of castor code (after any colourway options)
Example: QTQ150G/MZPTBBC

Order codes

Wheel	Fork	Castor
QTQ150G	M150ZP	QTQ150G/MZP
	M150ZPTB	QTQ150G/MZPTB
	M150ZPDL	QTQ150G/MZPDL
	M150ZFN	QTQ150G/MZFN
	M150ZH	QTQ150G/MZH
	M150ZHTB	QTQ150G/MZHTB
QTQ175G	M150ZHDL	QTQ150G/MZHDL
	M175ZP	QTQ175G/MZP
	M175ZPTB	QTQ175G/MZPTB
	M175ZPDL	QTQ175G/MZPDL
	M175ZH	QTQ175G/MZH
	M175ZHTB	QTQ175G/MZHTB
	M175ZHDL	QTQ175G/MZHDL

* Wheel also available with plain bearing—QTA.

¹ North American plate. Add **N** to the end of fork code to purchase (eg. QTQ175G/MZPNTB).

² Bushes available to reduce bolt hole to 8 and 10 mm (see page 69).

Y Series 50–360 kg



Features

- Available with puncture-proof neoprene tyres on steel rims or traditional pneumatic neoprene tyres on steel or plastic rims, in non-marking grey or black.
- Swivel or fixed plate zinc plated forks.
- Not available with brakes.

Steel rim wheels



YPRIB200
Puncture-proof grey tyre, precision bearing



**YPLUG250/
YSLUG250**
Puncture-proof or pneumatic black tyre, deep groove ball bearing



**YPSTR350/
YSSTR350**
Puncture-proof or pneumatic black tyre, precision bearing



**YPKNO400/
YSKNO400**
Puncture-proof or pneumatic black tyre, B deep groove ball bearing



YSHWY400
Pneumatic black tyre, Q ball precision bearing

Plastic rim wheels



YRIB200
Grey tyre, roller bearing



YLUG250
Black tyre, deep groove ball bearing



YSTR350
Black tyre, precision bearing



YKNO400
Black tyre, deep groove ball bearing

Specifications

Wheel	Type	Max load (kg)	Diameter x tread (mm)
YPRIB200	Puncture-proof	50	200 x 50
YPLUG250	Puncture-proof	75	220 x 54
YPSTR350	Puncture-proof	100	265 x 70
YPKNO400	Puncture-proof	120	400 x 100
YSLUG250	Pneumatic, steel	120	220 x 54
YSSTR350	Pneumatic, steel	180	265 x 70
YSKNO400	Pneumatic, steel	220	400 x 100
YSHWY400	Pneumatic, steel	360	400 x 100
YRIB200	Pneumatic, plastic	75	200 x 50
YLUG250	Pneumatic, plastic	100	220 x 54
YSTR350	Pneumatic, plastic	140	265 x 70
YKNO400	Pneumatic, plastic	200	400 x 100

Maximum inflation

Do NOT inflate over recommended tyre inflation pressure (30 psi).

Do NOT allow tyre pressure to drop below 20 psi or wheel may deflate and become very difficult to re-inflate. If you allow the tyre to go flat and you are unable to re-inflate it then you may need to buy an inner tube to be retro fitted to the wheel (see page 71 for spare parts).

Use of pneumatic wheels other than as recommended can be dangerous.

Forks



YZP
Plate with swivel



YZF
Fixed plate,
no swivel

Forks	Nominal size	Mount height (mm)	Turning radius (mm)
YZP/YZF*	200	238	155
	250	250	200
	350	315	223
	400	490	328

Fork mounts

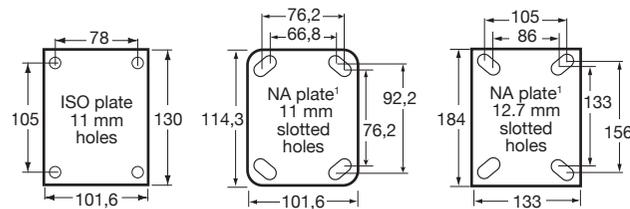

Standard:
ISO plate for 200,
250 and 350 mm
wheel sizes.

Optional:
NA plate for 250 mm
wheel sizes.

Standard:
NA plate for 400 mm
(400X8) wheel sizes.

* YZF fixed fork has no turning radius.
400 mm forks available in NA (North American) plate only.

¹ For North American plate add **N** to end of fork code to purchase (eg. YRIB250/YZPN).

Order codes

Wheel code	Fork code	Castor code
YPRIB200	Y200ZP	YPRIB200/YZP
	Y200ZF	YPRIB200/YZF
YPLUG250	Y250ZP	YPLUG250/YZP
	Y250ZF	YPLUG250/YZF
YPSTR350	Y350ZP	YPSTR350/YZP
	Y350ZF	YPSTR350/YZF
YPKNO400	Y400ZPN	YPKNO400/YZPN
	Y400ZFN	YPKNO400/YZFN
YSLUG250	Y250ZP	YSLUG250/YZP
	Y250ZF	YSLUG250/YZF
YSSTR350	Y350ZP	YSSTR350/YZP
	Y350ZF	YSSTR350/YZF
YSKNO400	Y400ZPN	YSKNO400/YZPN
	Y400ZFN	YSKNO400/YZFN
YSHWY400	Y400ZPN	YSHWY400/YZPN
	Y400ZFN	YSHWY400/YZFN
YRIB200	Y200ZP	YRIB200/YZP
	Y200ZF	YRIB200/YZF
YLUG250	Y250ZP	YLUG250/YZP
	Y250ZF	YLUG250/YZF
YSTR350	Y350ZP	YSTR350/YZP
	Y350ZF	YSTR350/YZF
YKNO400	Y400ZPN	YKNO400/YZPN
	Y400ZFN	YKNO400/YZFN



J Series 150–300 kg



Features

- Blue high resilience (hi-res) rubber, cast iron, polyurethane (PU) or hard nylon wheels.
- Swivel, fixed plate and bolt hole zinc plated Core Coat™ forks with or without total brake. Core Coat™ lacquer provides best quality corrosion protection, with no white or red rust after 150 hours of salt spray testing.
- Made in Australia.

Wheels



JBR*

Blue hi-res rubber, roller bearing, optional thread guard¹

JCR*²

Cast iron, roller bearing

JNR*³

Hard nylon, roller bearing, optional thread guard¹

JUR*

PU, roller bearing, optional thread guard¹

Wheel	Max load (kg)	Diameter x tread (mm)	Hub x bore (mm)	Bore—no bush (mm)
JBR100	150	100 x 32	45 x 10	20
JBR125	180	125 x 32	45 x 10	20
JCR100	230	100 x 38	45 x 10	20
JNR100	300	100 x 35	45 x 10	20
JNR125	300	125 x 35	45 x 10	20
JUR100	300	100 x 32	45 x 10	20
JUR125	300	125 x 38	45 x 10	20

* Wheels also available with plain bearings—JBA, JCI, JNA, JUA.

¹ For optional thread guards, add **G** to the end of wheel code.

² JCR or JCI wheel is not compatible with total brake forks.

³ JNR actual bore size is 12.7 mm reduced to 10 mm with an axle bush.

Forks



JZP

Plate with swivel

JZPTB²

Plate with swivel and total brake

JZF

Fixed plate, no swivel

JZH

Bolt hole swivel

JZHTB

Bolt hole swivel and total brake

Forks	Wheel size (mm)	Mount height (mm)	Turning radius (mm)
JZP/JZH/JZF ²	100	129	90
	125	155	106
JZPTB/JZHTB	100	129	122
	125	155	122

Fork mounts

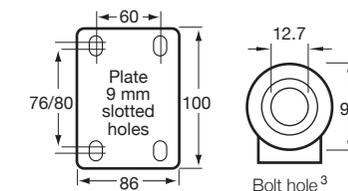

² JZF—fixed plate has no turning radius.

³ Bushes available to reduce bolt hole to 8 and 10 mm in round swivel race castors (see page 69).

Also available with a 16 mm bolt hole fork as a custom order.

Order codes

Wheel code	Fork code	Castor code
JBR100	J100ZP	JBR100/JZP
	J100ZPTB	JBR100/JZPTB
	J100ZF	JBR100/JZF
	J100ZH	JBR100/JZH
	J100ZHTB	JBR100/JZHTB
JBR125	J125ZP	JBR125/JZP
	J125ZPTB	JBR125/JZPTB
	J125ZF	JBR125/JZF
	J125ZH	JBR125/JZH
	J125ZHTB	JBR125/JZHTB
JCR100	J100ZP	JCR100/JZP
	J100ZF	JCR100/JZF
	J100ZH	JCR100/JZH

Wheel code	Fork code	Castor code
JNR100	J100ZP	JNR100/JZP
	J100ZPTB	JNR100/JZPTB
	J100ZF	JNR100/JZF
	J100ZH	JNR100/JZH
	J100ZHTB	JNR100/JZHTB
JNR125	J125ZP	JNR125/JZP
	J125ZPTB	JNR125/JZPTB
	J125ZF	JNR125/JZF
	J125ZH	JNR125/JZH
	J125ZHTB	JNR125/JZHTB

Wheel code	Fork code	Castor code
JUR100	J100ZP	JUR100/JZP
	J100ZPTB	JUR100/JZPTB
	J100ZF	JUR100/JZF
	J100ZH	JUR100/JZH
	J100ZHTB	JUR100/JZHTB
JUR125	J125ZP	JUR125/JZP
	J125ZPTB	JUR125/JZPTB
	J125ZF	JUR125/JZF
	J125ZH	JUR125/JZH
	J125ZHTB	JUR125/JZHTB



O Series 230–500 kg



Features

- Blue high resilience (hi-res) rubber, grey rubber, polyurethane (PU), or hard nylon wheels.
- Swivel or fixed plate zinc plated Core Coat™ forks with or without total brake or direction lock. Core Coat™ lacquer provides best quality corrosion protection, with no white or red rust after 150 hours of salt spray testing.
- Made in Australia.

Wheels



HBR* ¹	OBQ	HSR* ¹	HUR*	ONR*
Blue hi-res rubber, roller bearing, optional thread guard ²	Blue hi-res rubber, round profile, precision bearing	Grey rubber, roller bearing, optional thread guard ²	PU on nylon, roller bearing	Hard nylon, roller bearing

Wheel	Max load (kg)	Diameter x tread (mm)	Hub x bore ³ (mm)	Bore—no bush (mm)
HBR150 ²	230	150 x 28	60 x 12.7	20
HBR200 ²	250	200 x 28	60 x 12.7	20
OBQ100	300	100 x 50	60 x 12.7	20
OBQ125	350	125 x 50	60 x 12.7	20
OBQ150	400	150 x 50	60 x 12.7	20
OBQ200	400	200 x 50	60 x 12.7	20
HSR200 ²	250	200 x 50	60 x 12.7	20
HUR100	400	100 x 40	60 x 12.7	20
HUR125	400	125 x 40	60 x 12.7	20
HUR150 ²	450	150 x 40	60 x 12.7	20
HUR200	500	200 x 48	60 x 12.7	20
ONR100	400	100 x 40	60 x 12.7	20
ONR125	400	125 x 40	60 x 12.7	20
ONR150	450	150 x 40	60 x 12.7	20
ONR200	500	200 x 40	60 x 12.7	20

* Wheels also available with plain bearings—HBA, HSA, HUA, ONA.

¹ HBR, HBA, HSR, HSA wheels in a 200 mm diameter are not compatible with total brake fork.

² For optional thread guards, add **G** to the end of wheel code.

³ Bore size is reduced to 12.7 mm with a spacer before fitting into a fork.

Forks



OZP	OZPTB ¹	OZPDL	HZF
Plate with swivel	Plate with swivel and total brake	Plate with swivel and direction lock	Fixed plate, no swivel

Forks	Wheel size (mm)	Mount height (mm)	Turning radius (mm)
OZP/HZF ⁴	100	138	96
	125	162	109
	150	189	121
	200	239	152
OZPTB/OZPDL	100	138	140
	125	162	140
	150	189	140
	200	239	162

Fork mounts

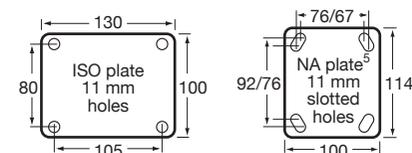

⁴ HZF—fixed plate has no turning radius.

⁵ North American plate. Add **N** to the end of fork code to purchase (eg. HBR150/OZPNTB).

Order codes

Wheel code	Fork code	Castor code
HBR150	O150ZP	HBR150/OZP
	H150ZF	HBR150/HZF
	O150ZPTB	HBR150/OZPTB
	O150ZPDL	HBR150/OZPDL
HBR200	O200ZP	HBR200/OZP
	H200ZF	HBR200/HZF
	O200ZPDL	HBR200/OZPDL
HSR200	O200ZP	HSR200/OZP
	H200ZF	HSR200/HZF
	O200ZPDL	HSR200/OZPDL
HUR100	O100ZP	HUR100/OZP
	H100ZF	HUR100/HZF
	O100ZPTB	HUR100/OZPTB
	O100ZPDL	HUR100/OZPDL
HUR125	O125ZP	HUR125/OZP
	H125ZF	HUR125/HZF
	O125ZPTB	HUR125/OZPTB
	O125ZPDL	HUR125/OZPDL
HUR150	O150ZP	HUR150/OZP
	H150ZF	HUR150/HZF
	O150ZPTB	HUR150/OZPTB
	O150ZPDL	HUR150/OZPDL
HUR200	O200ZP	HUR200/OZP
	H200ZF	HUR200/HZF
	O200ZPTB	HUR200/OZPTB
	O200ZPDL	HUR200/OZPDL

Wheel code	Fork code	Castor code
OBQ100	O100ZP	OBQ100/OZP
	H100ZF	OBQ100/HZF
	O100ZPTB	OBQ100/OZPTB
	O100ZPDL	OBQ100/OZPDL
OBQ125	O125ZP	OBQ125/OZP
	H125ZF	OBQ125/HZF
	O125ZPTB	OBQ125/OZPTB
	O125ZPDL	OBQ125/OZPDL
OBQ150	O150ZP	OBQ150/OZP
	H150ZF	OBQ150/HZF
	O150ZPTB	OBQ150/OZPTB
	O150ZPDL	OBQ150/OZPDL
OBQ200	O200ZP	OBQ200/OZP
	H200ZF	OBQ200/HZF
	O200ZPTB	OBQ200/OZPTB
	O200ZPDL	OBQ200/OZPDL

Wheel code	Fork code	Castor code
ONR100	O100ZP	ONR100/OZP
	H100ZF	ONR100/HZF
	O100ZPTB	ONR100/OZPTB
	O100ZPDL	ONR100/OZPDL
ONR125	O125ZP	ONR125/OZP
	H125ZF	ONR125/HZF
	O125ZPTB	ONR125/OZPTB
	O125ZPDL	ONR125/OZPDL
ONR150	O150ZP	ONR150/OZP
	H150ZF	ONR150/HZF
	O150ZPTB	ONR150/OZPTB
	O150ZPDL	ONR150/OZPDL
ONR200	O200ZP	ONR200/OZP
	H200ZF	ONR200/HZF
	O200ZPTB	ONR200/OZPTB
	O200ZPDL	ONR200/OZPDL



H Series 400–600 kg



Features

- Blue high resilience (hi-res) rubber, cast iron, hard nylon or polyurethane (PU) wheels with a 20 mm bore diameter, reduced to 12.7 mm with an axle bush.
- Swivel or fixed plate zinc plated Core Coat™ forks with or without total brake or direction lock. Core Coat™ lacquer provides best quality corrosion protection, with no white or red rust after 150 hours of salt spray testing.
- Made in Australia.

Fork mounts

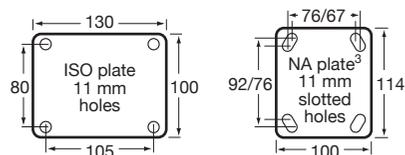

Wheels



OBQ*

Blue hi-res rubber, round profile, precision bearing

WCI¹

Cast iron, plain bearing

WNQ⁴

Hard nylon, precision bearing

WUQ⁴

PU, precision bearing

Wheel	Max load (kg)	Diameter x tread (mm)	Hub x bore (mm)	Bore—no bush (mm)
OBQ150	400	150 x 50	60 x 12.7	20
OBQ200	400	200 x 50	60 x 12.7	20
WCI150	400	150 x 50	60 x 12.7	20
WNQ150	600	150 x 40	60 x 12.7	20
WNQ200	600	200 x 40	60 x 12.7	20
WUQ150	600	150 x 40	60 x 12.7	20
WUQ200	600	200 x 40	48 x 12.7	20

Forks



HZP

Plate with swivel

HZPTB¹

Plate with swivel and total brake

HZPDL*

Plate with swivel and direction lock

HZF

Fixed plate, no swivel

Forks	Wheel size (mm)	Mount height (mm)	Turning radius (mm)
HZP/HZF ²	150	189	121
	200	239	155
HZPTB/HZPDL	150	189	165
	200	239	165

Order codes

Wheel code	Fork code	Castor code
OBQ150	H150ZP	OBQ150/HZP
	H150ZF	OBQ150/HZF
	H150ZPTB	OBQ150/HZPTB
OBQ200	H200ZP	OBQ200/HZP
	H200ZF	OBQ200/HZF
	H200ZPTB	OBQ200/HZPTB
WCI150	H150ZP	WCI150/HZP
	H150ZF	WCI150/HZF
	H150ZPDL	WCI150/HZPDL
WNQ150	H150ZP	WNQ150/HZP
	H150ZF	WNQ150/HZF
	H150ZPTB	WNQ150/HZPTB
	H150ZPDL	WNQ150/HZPDL
WNQ200	H200ZP	WNQ200/HZP
	H200ZF	WNQ200/HZF
	H200ZPTB	WNQ200/HZPTB
	H200ZPDL	WNQ200/HZPDL
WUQ150	H150ZP	WUQ150/HZP
	H150ZF	WUQ150/HZF
	H150ZPTB	WUQ150/HZPTB
	H150ZPDL	WUQ150/HZPDL
WUQ200	H200ZP	WUQ200/HZP
	H200ZF	WUQ200/HZF
	H200ZPTB	WUQ200/HZPTB
	H200ZPDL	WUQ200/HZPDL

* OBQ wheel is not compatible with direction lock fork.

¹ WCI wheel is not compatible with total brake fork.

² HZF—fixed plate has no turning radius.

³ North American plate. Add **N** to the end of fork code to purchase (eg. OBQ150/HZPNTB).

⁴ WNQ and WUQ wheels have a 48 mm hub when not used in conjunction with reducers and spacers (relevant to 200 mm wheels only).

H Series scaffold 360–500 kg

Features

- Castors are branded with maker's name, and Safe Working Load (SWL).
- Supplied with a test certificate validating compliance to Australian Standards (important for risk management documentation).
- The static collapse load exceeds three times the working load (certificate available).
- Wheels 150 mm (6") and 200 mm (8") diameter to safely pass over obstacles without snagging and causing scaffold to tip.
- The stem of the castor is 150 mm (6") long, with not more than 3 mm (1/8") of clearance to tube.
- A means is provided for fixing castor to tube, so it will not fall out when lifted.
- An effective wheel/swivel brake is fitted to ensure maximum stability.
- Sockets are to suit 48.3 mm OD tube, while spigots (solid stems) are to suit 38.5 mm ID tube.
- Core Coat™ lacquer provides best quality corrosion protection (150 hours of salt spray test).
- For wheel information see 'O Series' on page 22.



Mount type	Wheel diameter (mm)	Max load (kg)	Castor code	Mount code
 <p>HUR wheel in zinc plated fork with total brake, and 51 mm socket mount to fit over 48.3 mm tubes.</p>  <p>Socket mounting to fit over tubes.</p>	150	360	HUR150/HZHTB	SC08
	200	500	HUR200/HZHTB	SC13
 <p>HUR wheel in zinc plated fork with total brake, and 38 mm solid stem with fully welded cup. Suits 38.5 mm ID tube.</p>  <p>Solid stem with fully welded cup.</p>	150	360	HUR150/HZPTB	SC62
	200	500	HUR200/HZPTB	SC15
 <p>HUR wheel in zinc plated fork with total brake, and 38 mm stem mount to fit into tubes. Suits 38.5 mm ID tube.</p>  <p>Stem mounting to fit into tubes.</p>	150	360	HUR150/HZHTB	SC30
	200	500	HUR200/HZHTB	SC11
 <p>HUR wheel in zinc plated fork with total brake, and ISO plate (130 x 100 mm).</p>  <p>ISO plate 130 x 100 mm.</p>	150	360	HUR150/HZPTB	SC61
	200	500	HUR200/HZPTB	SC18

W Series 500–750 kg



Features

- Cast iron, hard nylon or polyurethane (PU) wheels.
- Swivel or fixed plate zinc forks with or without total brake.

Wheels



WCI

Cast iron,
plain bearing

WNQ

Hard nylon,
precision
bearing

WUQ

PU, precision
bearing

XUQ

PU on cast
iron, precision
bearing

Wheel	Max load (kg)	Diameter x tread (mm)	Hub x bore (mm)	Bore—no bush (mm)
WCI150	500	150 x 50	60 x 12.7	20
WNQ150	600	150 x 40	60 x 12.7	20
WUQ150	600	150 x 40	60 x 12.7	20
XUQ150	750	152 x 50	62 x 12.7	20

Forks



WZP

Plate with swivel

WZPTB

Plate with swivel and
total brake

WZF

Fixed plate,
no swivel

Forks	Wheel size (mm)	Mount height (mm)	Turning radius (mm)
WZP/WZF*	150	194	130
WZPTB	150	194	176

Fork mount

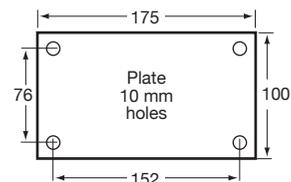

* WZF—fixed plate has no turning radius

Order codes

Wheel code	Fork code	Castor code
WCI150	W150ZP	WCI150/WZP
	W150ZF	WCI150/WZF
	W150ZPTB	WCI150/WZPTB
WNQ150	W150ZP	WNQ150/WZP
	W150ZF	WNQ150/WZF
	W150ZPTB	WNQ150/WZPTB
WUQ150	W150ZP	WUQ150/WZP
	W150ZF	WUQ150/WZF
	W150ZPTB	WUQ150/WZPTB
XUQ150	W150ZP	XUQ150/WZP
	W150ZF	XUQ150/WZF
	W150ZPTB	XUQ150/WZPTB

Dumper bin sets

Castor sets comprising two fixed and two swivel castors can be purchased for dumper bin applications. Please note that as rubbish trucks often drop dumper bins after tipping, using these castors in such applications reduce the warranty period to six months.

Wheel code	Order code
WCI150	SETDUMPERWCI
WNQ150	SETDUMPERWNQ
WUQ150	SETDUMPERWUQ
XUQ150	SETDUMPERXUQ

X Series 450–1000 kg



Features

- Cast iron or polyurethane (PU) on cast iron wheels.
- Swivel and fixed plate zinc forks with wheel brake or direction lock.
- Kingpin construction.

Fork mount

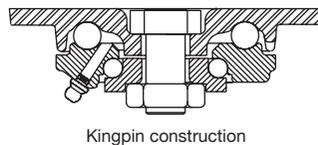
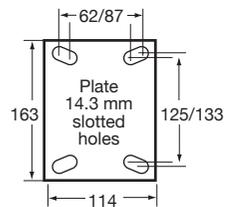

Spare parts: Brakes and directional locks

Spare part retrofit brake kit for 100 mm castor	SPBRKX100BR
Spare part retrofit brake kit for 125 mm castor	SPBRKX125BR
Spare part retrofit brake kit for 150 mm castor	SPBRKX150BR
Spare part retrofit brake kit for 200 mm castor	SPBRKX200BR
X Series directional locking pins for 100, 125, 150 & 200 mm castors	SPBRKXDL

* Directional locking pins can be used in conjunction with wheel brakes but must be purchased as an additional retrofit item.

Wheels



XCQ
Cast iron, precision bearing



XUQ
PU on cast iron, precision bearing

Wheel	Max load (kg)	Diameter x tread (mm)	Hub x bore (mm)	Bore—no bush (mm)
XCQ100	450	102 x 48	62 x 12.7	20
XCQ125	590	127 x 48	62 x 12.7	20
XCQ150	630	152 x 48	62 x 12.7	20
XCQ200	820	203 x 50	62 x 12.7	20
XUQ100	600	102 x 50	62 x 12.7	20
XUQ125	800	127 x 50	62 x 12.7	20
XUQ150	1000	152 x 50	62 x 12.7	20
XUQ200	1000	203 x 50	62 x 12.7	20

Forks



XZP Plate with swivel
XZPBR Plate with swivel and wheel brake
XZPDL Plate with swivel and direction lock
XZF Fixed plate, no swivel

Forks	Wheel size	Mount height (mm)	Turning radius (mm)
XZP/XZPDL XZF*	100	143	95
	125	167	108
	150	193	137
	200	257	162
XZPBR	100	143	219
	125	167	242
	150	193	266
	200	257	291

Order codes

Wheel code	Fork code	Castor code
XCQ100	X100ZP	XCQ100/XZP
	X100ZF	XCQ100/XZF
	X100ZPBR	XCQ100/XZPBR
	X100ZPDL	XCQ100/XZPDL
XCQ125	X125ZP	XCQ125/XZP
	X125ZF	XCQ125/XZF
	X125ZPBR	XCQ125/XZPBR
	X125ZPDL	XCQ125/XZPDL
XCQ150	X150ZP	XCQ150/XZP
	X150ZF	XCQ150/XZF
	X150ZPBR	XCQ150/XZPBR
	X150ZPDL	XCQ150/XZPDL
XCQ200	X200ZP	XCQ200/XZP
	X200ZF	XCQ200/XZF
	X200ZPBR	XCQ200/XZPBR
	X200ZPDL	XCQ200/XZPDL
XUQ100	X100ZP	XUQ100/XZP
	X100ZF	XUQ100/XZF
	X100ZPBR	XUQ100/XZPBR
	X100ZPDL	XUQ100/XZPDL
XUQ125	X125ZP	XUQ125/XZP
	X125ZF	XUQ125/XZF
	X125ZPBR	XUQ125/XZPBR
	X125ZPDL	XUQ125/XZPDL
XUQ150	X150ZP	XUQ150/XZP
	X150ZF	XUQ150/XZF
	X150ZPBR	XUQ150/XZPBR
	X150ZPDL	XUQ150/XZPDL
XUQ200	X200ZP	XUQ200/XZP
	X200ZF	XUQ200/XZF
	X200ZPBR	XUQ200/XZPBR
	X200ZPDL	XUQ200/XZPDL

* XZF—fixed plate has no turning radius.

V Series 2000–2450 kg



Features

- Polyurethane (PU) on cast iron, or high impact polymer wheels.
- Swivel or fixed plate zinc forks with or without wheel brake or direction lock.
- Kingpinless construction.

Wheels



VUQ
PU on cast iron, precision bearing



VXQ
High impact polymer, precision bearing

Wheel	Max load (kg)	Diameter x tread (mm)	Hub x bore (mm)	Bore—no bush (mm)
VUQ200	2000	203 x 75	89 x 20	30
VUQ250	2000	254 x 75	89 x 20	30
VXQ200	2450	200 x 75	89 x 20	30
VXQ250	2450	250 x 75	89 x 20	30

Forks



VZP
Plate with swivel



VZPBR
Plate with swivel and wheel brake



VZPDL
Plate with swivel and direction lock



VZF
Fixed plate, no swivel

Forks	Wheel size	Mount height (mm)	Turning radius (mm)
VZP/VZPDL/ VZF*	200	267	165
	250	318	190
VZPBR	200	267	317
	250	318	353

Fork mount

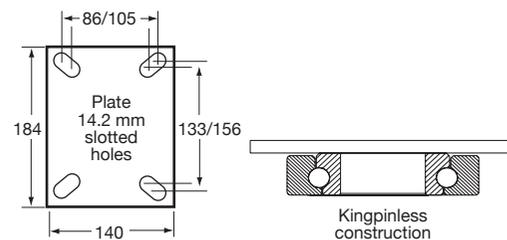

Order codes

Wheel code	Fork code	Castor code
VUQ200	V200ZP	VUQ200/VZP
	V200ZF	VUQ200/VZF
	V200ZPBR	VUQ200/VZPBR
	V200ZPDL	VUQ200/VZPDL
VUQ250	V250ZP	VUQ250/VZP
	V250ZF	VUQ250/VZF
	V250ZPBR	VUQ250/VZPBR
	V250ZPDL	VUQ250/VZPDL
VXQ200	V200ZP	VXQ200/VZP
	V200ZF	VXQ200/VZF
	V200ZPBR	VXQ200/VZPBR
	V200ZPDL	VXQ200/VZPDL
VXQ250	V250ZP	VXQ250/VZP
	V250ZF	VXQ250/VZF
	V250ZPBR	VXQ250/VZPBR
	V250ZPDL	VXQ250/VZPDL

* VZF—fixed plate has no turning radius.

Spare parts: Brakes and directional locks

Description	Order code
Spare part retrofit brake kit for 200 mm castor	SPBRKV200BR
Spare part retrofit brake kit for 250 mm castor	SPBRKV250BR
V Series directional locking pins (suits 200 mm and 250 mm castors)	BRKVDL

Directional locking pins can be used in conjunction with wheel brakes, but must be purchased as an additional retrofit item.

A Series 3000–3500 kg



Features

- Polyurethane (PU) on cast iron wheel.
- Swivel or fixed plate zinc forks with or without wheel brake or direction lock.
- Kingpinless construction.

Wheels



AUQ
PU on cast iron, precision bearing

Wheel	Max load (kg)	Diameter x tread (mm)	Hub x bore (mm)	Bore—no bush (mm)
AUQ200	3000	200 x 102	109 x 30	30
AUQ250	3500	250 x 102	109 x 30	30

Forks



AZP Plate with swivel
AZPBR Plate with swivel and wheel brake
AZPDL Plate with swivel and direction lock
AZF Fixed plate, no swivel

Forks	Wheel size	Mount height (mm)	Turning radius (mm)
AZP/AZPDL/ AZF*	200	279	172
	250	330	197
AZPBR	200	279	317
	250	330	353

Fork mount

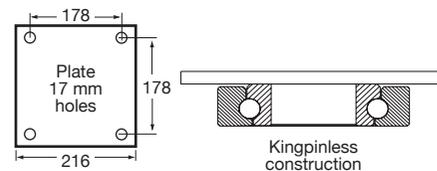

* AZF—fixed plate has no turning radius.

Order codes

Wheel code	Castor code
AUQ200 Diameter: 200 mm	AUQ200/AZP
	AUQ200/AZF
	AUQ200/AZPBR
	AUQ200/AZPDL
AUQ250 Diameter: 250 mm	AUQ250/AZP
	AUQ250/AZF
	AUQ250/AZPBR
	AUQ250/AZPDL

Spare parts: Brakes and directional locks

Description	Order code
Spare part retrofit brake kit for 200 mm castor	SPBRKA200BR
Spare part retrofit brake kit for 250 mm castor	SPBRKA250BR
A Series directional locking pin (suits 200 mm and 250 mm castors)	SPBRKADL

Directional locking pins can be used in conjunction with wheel brakes, but must be purchased as an additional retrofit item.

Decorative castors

Our decorative castor ranges present alternative finishes for our popular K series (page 12) and M series (page 14) ranges. Each range comes with Chicago screw axles, that provide an elegant domed head on both sides of the wheel. We utilise pearlescent pigment in the thread guards for high-lustre sheen.

If you're looking for serious working castors, that can cope with constant use in applications such as room service trolleys (that clock up a lot of miles); but don't want industrial castors to stand out and foul the general aesthetic of your curated ambiance, then you're in the right place!

The Arc range

The Arc colourways are light and neutral, ideally suited to modern, contemporary furniture, with wheel options in graphite, silver, white and grey.

The decorative finishes include powder-coating in Anodic Natural Matt, with grey pedals and seals. Ideal for café tables, moveable boardroom furniture and design applications requiring a cool, clean finish.

The Midnight Black range

The Midnight Black colourway has a satin black finish, designed to escape notice and seamlessly blend into shadow. Midnight Black castors are powder-coated in NightSky™ (a true black from Colorbond's range).

From casino gaming tables, to shopfitting cabinetry, the Midnight Black range won't stand out or jar with your overall design.

The M Deluxe range

M Deluxe is finished in bright chrome, combined with high-lustre bluestone trims, bringing elegant sophistication to hospitality equipment and furniture.



Arc



Features

- Anodic Natural Matt powder-coated forks with grey pedals and seals.
- Available in K and M series TPE wheels in graphite, silver and white colourways.
- Chicago screw axles and pearlescent thread guards.
- Suitable for modern contemporary furniture.
- Other sizes available subject to minimum orders.
- Made in Australia.



Wheels



**K SERIES
KJQ75G**
TPE, precision bearing, thread guard



**M SERIES
MJQ100G**
TPE, precision bearing, thread guard

K Series forks



KPP
Plate with swivel



KPPTB
Plate with swivel and total brake



KPH
Bolt hole swivel



KPHTB
Bolt hole swivel and total brake

M Series forks



MPP
Plate with swivel



MPPTB
Plate with swivel and total brake



MPH
Bolt hole swivel



MPHTB
Bolt hole swivel and total brake

Colourways



GH
Graphite



SL
Silver



WT
White

Specifications

Wheel	Max load (kg)	Diameter x tread (mm)	Hub x bore (mm)
KJQ75G	50	75 x 23	30 x 8
MJQ100G	85	100 x 32	40 x 8

Forks	Wheel size (mm)	Mount height (mm)	Turning radius (mm)
KPP/KPH	75	104	69
KPPTB/KPHTB	75	104	89
MPP/MPH	100	135	91
MPPTB/MPHTB	100	135	128

K Series fork mount

M Series fork mount

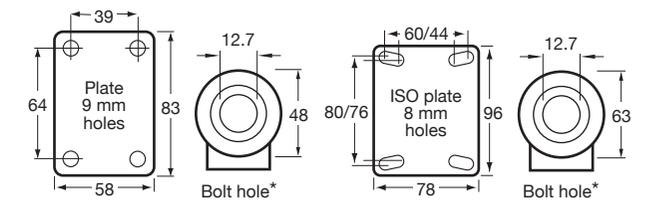

Order codes

Wheel code	Fork code	Castor code	Colourway
KJQ75G	K75PPARC	KJQ75G/KPP	+ ___
	K75PPTBARC	KJQ75G/KPPTB	+ ___
	K75PHARC	KJQ75G/KPH	+ ___
	K75PHTBARC	KJQ75G/KPHTB	+ ___
MJQ100G	M100PPARC	MJQ100G/MPP	+ ___
	M100PPTBARC	MJQ100G/MPPTB	+ ___
	M100PHARC	MJQ100G/MPH	+ ___
	M100PHTBARC	MJQ100G/MPHTB	+ ___

* Bushes available to reduce bolt hole to 8 and 10 mm (see page 69).

Midnight Black



Wheels



K SERIES KJQ75GBLK
TPE, precision bearing,
thread guard



M SERIES MJQ100GBLK
TPE, precision bearing,
thread guard

K Series forks



KPP
Plate with
swivel



KPPTB
Plate with
swivel and
total brake



KPH
Bolt hole swivel



KPHTB
Bolt hole
swivel and
total brake

M Series forks



MPP
Plate with
swivel



MPPTB
Plate with
swivel and
total brake



MPH
Bolt hole
swivel



MPHTB
Bolt hole
swivel and
total brake

Features

- NightSky™ (Colorbond black satin).
- Available in K Series or M Series thermoplastic elastomer (TPE) wheels with black thread guards and Chicago screw axles.
- Suitable for complementing timber and steel furniture.
- Other sizes available subject to minimum orders.
- Made in Australia.

Specifications

Wheel	Max load (kg)	Diameter x tread (mm)	Hub x bore (mm)
KJQ75GBLK	50	75 x 23	30 x 8
MJQ100GBLK	85	100 x 32	40 x 8

Forks	Wheel size (mm)	Mount height (mm)	Turning radius (mm)
KPP/KPH	75	104	69
KPPTB/KPHTB	75	104	89
MPP/MPH	100	135	91
MPPTB/MPHTB	100	135	128

K Series fork mount

M Series fork mount

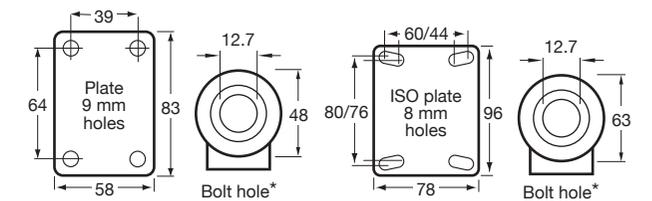

Order codes

Wheel code	Fork code	Castor code
KJQ75GBLK	K75PPBLK	KJQ75G/KPPBLK
	K75PPTBBLK	KJQ75G/KPPTBBLK
	K75PHBLK	KJQ75G/KPHBLK
	K75PHTBBLK	KJQ75G/KPHTBBLK
MJQ100GBLK	M100PPBLK	MJQ100G/MPPBLK
	M100PPTBBLK	MJQ100G/MPPTBBLK
	M100PHBLK	MJQ100G/MPHBLK
	M100PHTBBLK	MJQ100G/MPHTBBLK

* Bushes available to reduce bolt hole to 8 and 10 mm (see page 69).



M Deluxe



Castor options



MJQ WHEEL
TPE, precision bearing, thread guard



MCP
Plate with swivel



MCPTB
Plate with swivel and total brake



MCF
Fixed plate, no swivel



MCH
Bolt hole swivel



MCHTB
Bolt hole swivel and total brake

Features

- Chrome plated forks with *Bluestone* pedals and seals.
- M Series 100 mm or 125 mm thermoplastic elastomer (TPE) wheels with *Bluestone* thread guards and Chicago screw axles.
- Complements high end furniture, displays or equipment.
- Other sizes available subject to minimum orders.
- Made in Australia.

Specifications

Wheel	Max load (kg)	Diameter x tread (mm)	Hub x bore (mm)
MJQ100G	85	100 x 32	40 x 8
MJQ125G	85	125 x 32	40 x 8

Forks	Wheel size (mm)	Mount height (mm)	Turning radius (mm)
MCP/MCF*/MCH	100	135	91
MCPTB/MCHTB	100	135	128
MCP/MCF*/MCH	125	161	91
MCPTB/MCHTB	125	161	128

M Series fork mount

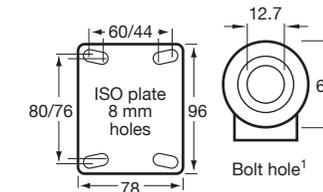

Order codes

Wheel code	Fork code	Castor code
MJQ100G	M100CPBN	MJQ100G/MCPBN
	M100CPTBBN	MJQ100G/MCPTBBN
	M100CFBN	MJQ100G/MCFBN
	M100CHBN	MJQ100G/MCHBN
	M100CHTBBN	MJQ100G/MCHTBBN
MJQ125G	M125CPBN	MJQ125G/MCPBN
	M125CPTBBN	MJQ125G/MCPTBBN
	M125CFBN	MJQ125G/MCFBN
	M125CHBN	MJQ125G/MCHBN
	M125CHTBBN	MJQ125G/MCHTBBN

* MCF – fixed plate has no turning radius.

¹ Bushes available to reduce bolt hole to 8 and 10 mm (see page 69).



Medical castors and wheels

Trinity series (including Trinity Electronic Braking Castors)

Designed for patient transport, Trinity three-in-one castors are renowned in the healthcare industry for their innovative three-in-one brake function, fixed brake pedal position and high dynamic load rating.

Built on this innovation, Trinity Electronic Braking Castors (EBC) feature automatic brakes, intuitive steering, and the control of brakes and steering from any castor foot pedal, handset or nurse panel.

Traditional central locking castors

Castors and fittings for traditional hospital beds with mechanical central locking systems.

Wheelchair castors

Moulded from high-impact nylon, spoked for less weight, fitted with sealed precision bearings and paired with lightweight foamed urethane tyres, our wheelchair castors are designed to be easy to use and maintenance free over its lifetime.

Conductive wheels

Non-marking conductive wheels for M Series castors.



Trinity series

Three-in-one castors

Designed for patient transport, Trinity castors are renowned in the healthcare industry for their innovative three-in-one brake function, fixed brake pedal position and high dynamic load rating.

Configuration

Trinity castors are available in three wheel sizes—100, 125 and 150 mm—and four brake configurations:

- Complete brake (CB)—includes all three brake positions.
- Total brake (TB)—includes TB and swivel.
- Swivel (SW)—free movement castor with no pedal.
- Blank castor (BL)—used to achieve bilateral braking. If used at the rear of equipment and combined with CB castors at the front, one activation bar can control all castors to achieve total brake, direction lock or free swivel (down = TB, horizontal = swivel, up = swivel).

Three-in-one brake pedal function

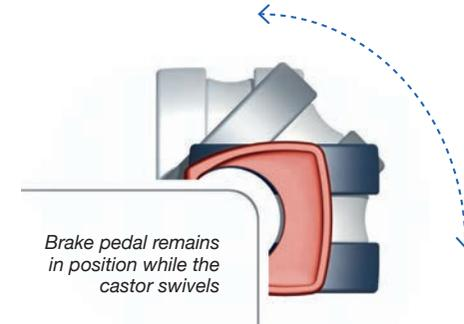

Fixed brake pedal position

A fixed brake pedal means that you can use the castor no matter where it's facing as the pedal will always be accessible. No more fishing under equipment to try to find the pedal.

Specifications

	Diameter (mm)	Max load (kg)	Height* (mm)	Turning radius (mm)
Swivel				
Swivel only	100	100	133	78
	125	125	161	104
	150	150	185	129
In-line pedal				
Pedal in-line with directional lock	100	100	133	78
	125	125	161	104
	150	150	185	129
90 degree pedal				
Pedal at 90 degree angle to directional lock	100	100	133	78
	125	125	161	104
	150	150	185	129

* Mount heights shown are for castors only. Fittings are additional—5 mm for washer, 14 mm for plate.



Electronic braking castors (EBC)

Three-in-one castor

Features across the range

- Innovative patented design.
- Suits a wide range of medical equipment and applications.
- Advanced braking system.
- Fixed position soft-touch actuation pedal.
- Available in 100, 125 and 150 mm wheel diameters.
- Made in Australia.

Innovative patented design

Trinity castors and Trinity EBC are designed in Australia and made under the following patents:

- USA patent 8205297 (12/663354).
- European patent 2164715.
- Australian patent 2008258348.
- International patent pending 20150266342.

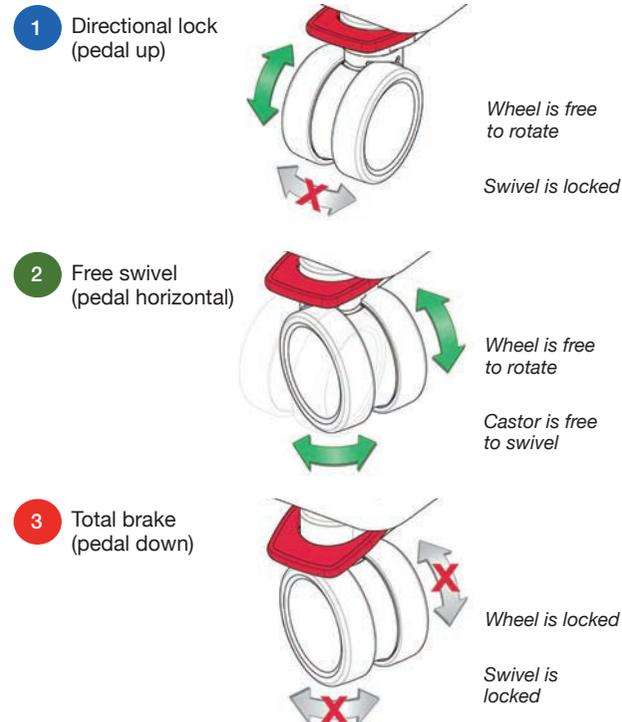

Take a closer look. Scan the QR code.

Electronic braking castors (EBC)

Built on the innovation of Trinity three-in-one castors, Trinity electronic braking castors (EBC) feature automatic brakes, intuitive steering, and the control of brakes and steering from any castor foot pedal, handset or nurse panel.

Never forget the brakes again

Where medical castors are used for moving patients and specialised equipment frequently, forgetting to apply the brakes presents a higher risk of accidents, especially if the patient tries to alight, or when hospital equipment unexpectedly moves.

Trinity EBC helps prevent these kinds of accidents by automatically applying the brakes when it has been stationary for a programmed time (normally 60 seconds). When you want to unlock the brakes again, the control is always within easy reach—just flick up any of the four castor pedals, or press the button on the handset or nurse control panel.

Steer like you flip your smart-phone

Just like your smart-phone decides whether to flip its display from portrait to landscape based on your pattern of movement, Trinity EBC analyses how you move the bed or equipment, and intelligently decides when and how to engage or disengage the directional lock.

Take a closer look.
Scan the QR code.



Control system

Trinity EBC is compatible with Dewert, TiMotion and Linak control systems. It is also fully customisable and can interface with customer-specific control systems. Pair an EBC set with the Fallshaw Control System to get the most out of Trinity EBC, or ask our engineers to help you retrofit EBC to your existing hospital bed system. Ask a Fallshaw representative for more information.

No power, no problem

In the unlikely event of a power cut, the castors can still be manually steered and locked through the pedals, just like a normal Trinity castor. This allows you to still use the bed normally.

Trinity EBC set

Trinity EBC can be ordered as a set. An EBC set consists of four castors—one motion sensing and conductive castor, and three standard castors.

Specifications

	100 mm wheel	125 mm wheel	150 mm wheel
Max load	100 kg	125 kg	150 kg
Mount height*	133 mm	161 mm	185 mm
Turning radius	78 mm	104 mm	129 mm
Standard fittings	<ul style="list-style-type: none"> • 32 mm pintle or 28 mm ISO pintle • Washer 		
Standard features	<ul style="list-style-type: none"> • IPX5 water resistance rating • Cool grey or eggshell colourway 		
Optional features	<ul style="list-style-type: none"> • Auto brake motion sensor • Intuitive steer motion sensor • Conductive (resistance <math>< 10^5</math> ohms) 		

* Add 5 mm for washer mount.



Trinity EBC can be used on a wide range of medical equipment, including hospital beds, mobile rehab robots and specialised surgical equipment.

How automatic braking and intuitive steering works

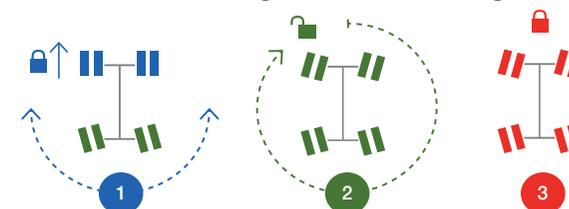

Purposeful movement in either direction engages the directional lock to the forward wheels, allowing the rear wheels to do the steering.

No movement for one second disengages the directional lock and allows free swivel movement to all four castors.

No movement for 60 seconds engages total brake on all four castors. This can be disengaged from the handset or by using any of the four pedals.

Trinity series

Trinity EBC control system

Core components



EBCCONTROLU (For user-specified handsets)
EBCCONTROLI (For Intuitive handset or panel)

EBC Controller



EBCCABLESET1.5 (Set of four 1.5 m cables)

Extension cable set



EBCCABLEY

Y cable



EBCPOWERAU (Australasian)
EBCPOWEREU (European)
EBCPOWERUK (UK)
EBCPOWERUS (US)

Power supply

User interface options (choose one only)



EBCHANDSETU1 (User-specified, 1 button)
EBCHANDSETU5 (User-specified, 5 button)
EBCHANDSETI1 (Intuitive, 1 button)
EBCHANDSETI6 (Intuitive, 6 button)

Handset



EBCINTERFACE (If using existing control panel)

Interface Box

Optional extras (choose only if your existing system requires a stand-alone battery)



EBCBATTERY1 (1.2AH)

Battery

Trinity EBC set: order codes

Castor series	Size	Pedal configuration	Colourway	Brake configuration	Steering type	Cable compatibility	Water resistance
EBCSET	100 100 mm	0 In-line	C Cool grey	CB Complete brake	I Intuitive	L Linak	5 IPX5
	125 125 mm	9 90°	E Eggshell	TB Total brake	U User specified	D Dewert	
	150 150 mm					T TiMotion	
EBCSET	—	—	—	—	—	—	—

Please note: The combination of *TB* (total brake) and *I* (intuitive steering) is unavailable in the Trinity EBCSET.

EBC sets include one conductive and motion-sensing castor, and three standard castors.

Trinity EBC colour coded feature identification

- Blue—Intuitive steering
- Black—Motion sensing
- Yellow—Conductive

Colourway options

Grey colourway

Body	Wheels	Pedal
Pantone 423C	Pantone 7546C	Pantone 288C

Eggshell colourway

Body	Wheels	Pedal
Pantone 7527C	Pantone 7546C	Pantone 7545C

Please note: Customised colours are available on request. Minimum order quantities apply.



Trinity series fitting options

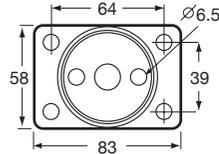

PLATE MOUNT SPFPLATEKIT

Includes:

- SPM14X40 (bolt)
- SPWSHFZDRILL (fitting washer)
- SPFPLATE (top plate)

Only compatible with 100 mm castors at full load rating.



TUBE MOUNT

Add solid pintle adapter:

- | | |
|-----------------|---|
| -AFR28Z(100) | Fits 100 mm castors, 28 mm round stem ² |
| -AFR28Z(125150) | Fits 125 mm & 150 mm castors, 28 mm round stem ² |
| -AFR32Z(100) | Fits 100 mm castors, 32 mm round stem ³ |
| -AFR32Z(125150) | Fits 125 mm & 150 mm castors, 32 mm round stem ³ |

WASHER MOUNT

Customer supplied M14 bolt and washer to ensure engagement into the castor of 30–38 mm (100) or 40–50 mm (125 and 150).



Laser cut mount
SPWSHFZLASER



Drill mount
SPWSHFZDRILL

Trinity stoppers

- Castors can be installed either with a pintle mount or washer mount (as per images below); however, the installation method must provide a 'stopper' to prevent over-extension of the pedal in the 'up' direction. This has been found to be critical to ensure long life of the product in the field and protect against the castors being damaged from abuse by kicking the pedal.
- Fallshaw can provide stoppers for this purpose or, manufacturers can design this into the bed frame (with our assistance).

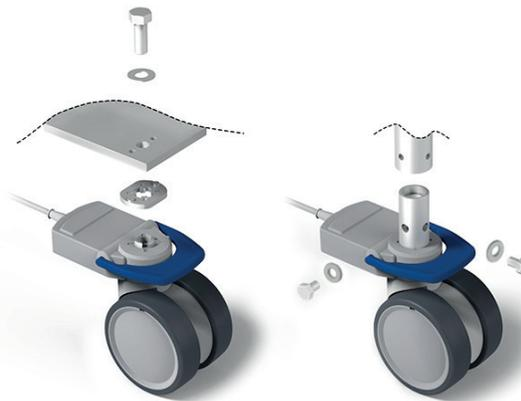

Stopper options

Application	Stopper	Order code
Total brake castor with tube mount		SPSTOPFPTLTBAN
Complete brake castor with tube mount		SPSTOPFPTLCBAN
Total brake castor with washer mount		SPSTOPFWSHTBBN
Complete brake castor with washer mount		SPSTOPFWSHCBBN

Trinity series

Trinity three-in-one castor: order codes

Castor series	Tyre material	Bearing	Size (mm)	Fork	Pedal	Colourway	Brake configuration	Fork design				
F	U Polyurethane	Q	100	F	0 In-line	C Cool grey	CB Complete brake	S Standard				
	A Conductive		125		9 90°	E Eggshell	TB Total brake		A Conductive			
			150				SW Swivel					
							BL Blank					
F	—	Q	—	F	—	—	—	—				



Trinity EBC (single castor): order codes

Castor series	Tyre material*	Bearing	Size (mm)	Fork	Pedal	Colourway	Brake configuration	Fork design*	Steering type ¹	Cable compatibility	Motion-sensing ¹	Water resistance			
F	U Polyurethane	Q	100	P	0 In-line	C Cool grey	CB Complete brake	S Standard	I Intuitive	L Linak	M Yes	5 IPX5			
	A Conductive		125		9 90°	E Eggshell	TB Total brake						A Conductive	D Dewert	N No
			150				BL Blank						U User specified	T TiMotion	
F	—	Q	—	P	—	—	—	—	—	—	—	—			



Please note: The combination of TB (total brake) and I (intuitive steering) is unavailable in the Trinity EBC.

* Tyre material and fork design—polyurethane tyre (U) can only be matched with standard fork (S). Conductive tyre (A) can only be matched with conductive fork.

¹ Steering type and motion sensing—intuitive steering (I) can only be matched with motion sensing (M: Yes).

² Cross drill hole: distance from end—19 mm, diameter—8 mm.

³ Cross drill hole: distance from end—7 mm, diameter—6 mm.

Take a closer look.
Scan the QR code.



Central locking castors

Traditional v Trinity EBC

We have two options for central locking castors for hospital beds—the traditional mechanical system, and the innovative Trinity EBC.

Traditional mechanical system

Made in Australia, these castors are operated via a foot pedal, which typically moves down for total brake, horizontal for swivel, and up for directional lock (steer). The foot pedal is connected via transmission levers and a hexagonal rod running through the bed undercarriage, which, in turn rotates cams inside the castors to control the brake state in all four castors centrally. Steering needs to be factory fitted to either steer from the head end or the foot end of the bed.



Traditional mechanical system fitted to a hospital bed frame

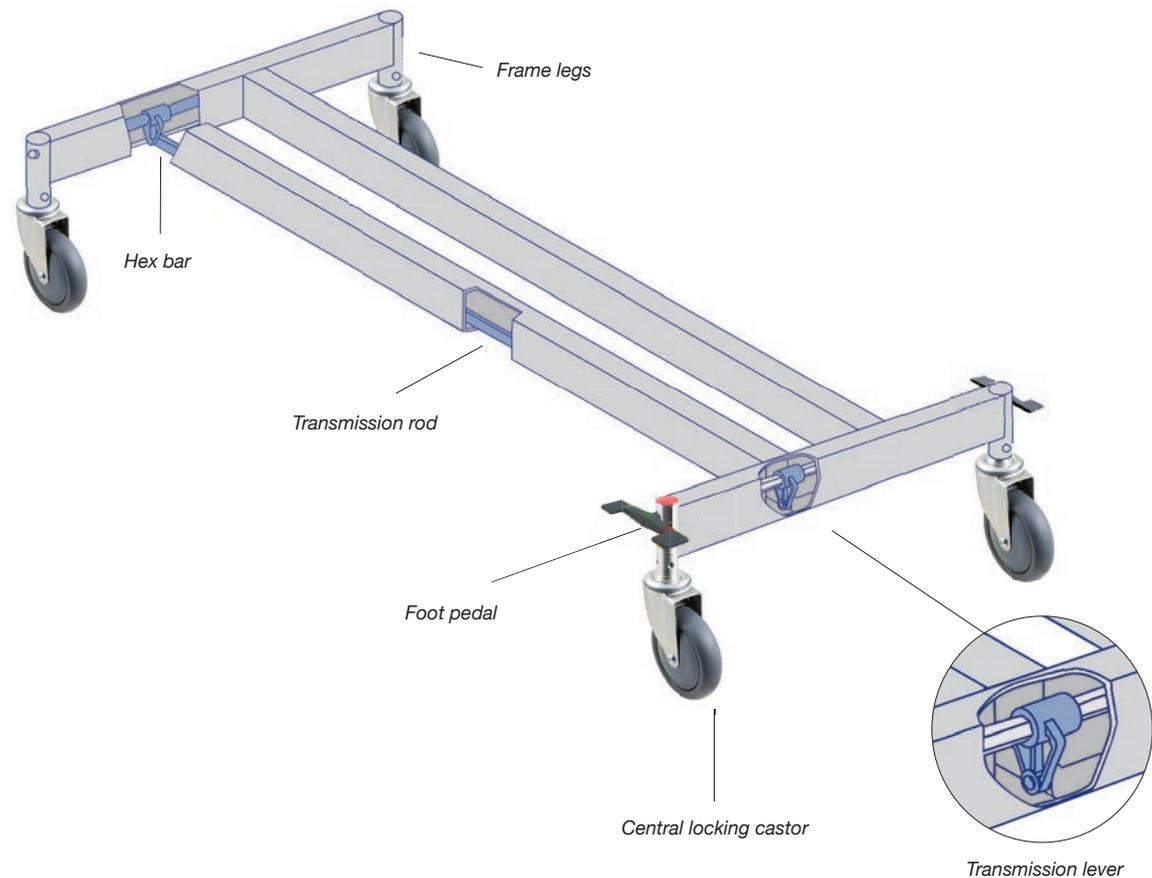

Trinity EBC system

Trinity EBC can be controlled with the push of a button via the handset, or by activating any of the four castors (which will then control their companion castors). Steering can flip from the head end of the bed to the foot end automatically.

The EBC technology connects all four castors with electronic cables instead of a hexagonal rod and transmission levers. This provides great flexibility in bed design, where the undercarriage no longer needs to provide for the rigid hexagonal bars, and the cables can bend to any shape. Additionally, Trinity EBC can be retro-fitted to existing hospital beds.



Trinity EBC system fitted to a hospital bed frame

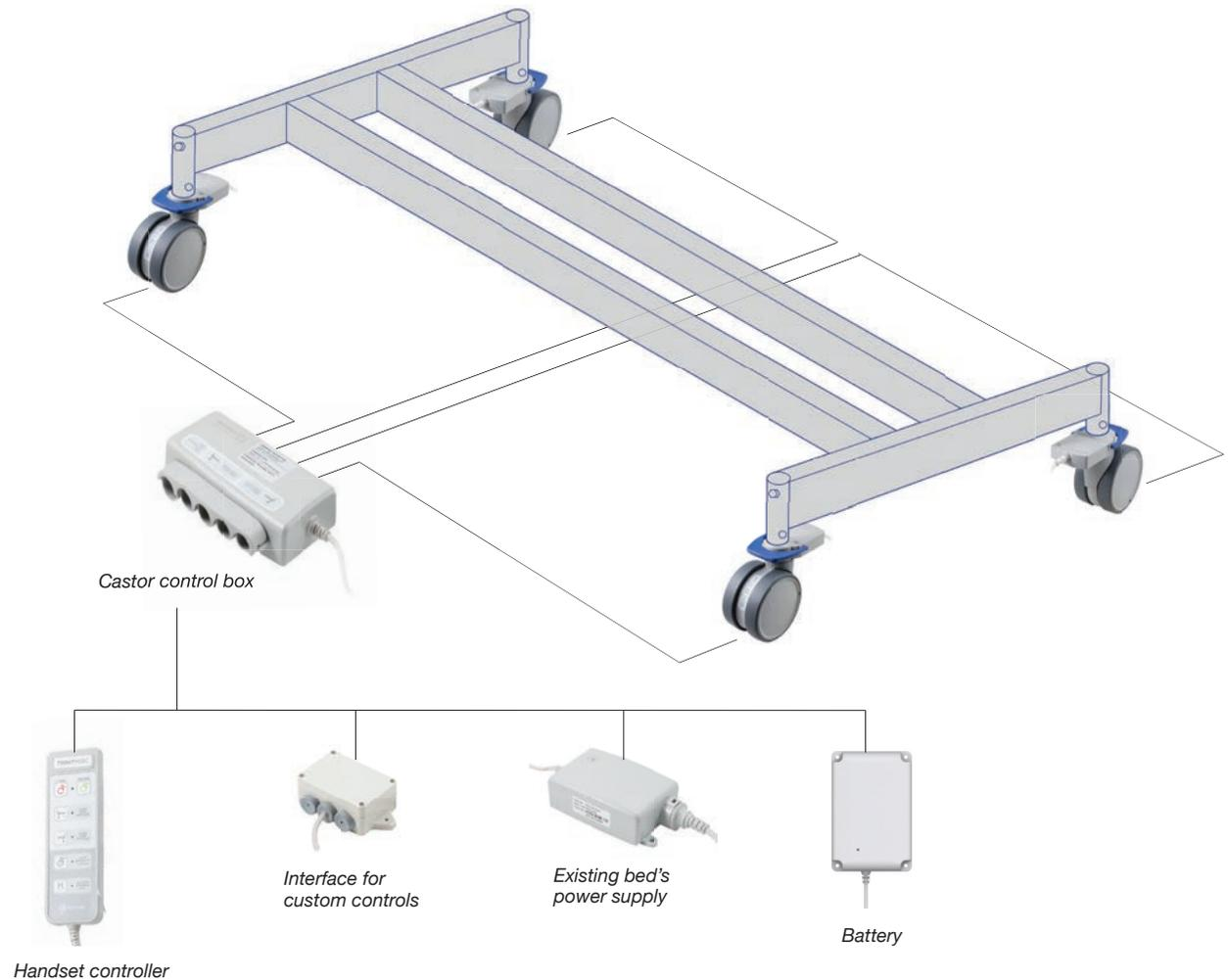

Traditional central locking castors



Features

- Suitable for use on hospital beds where one pedal needs to activate multiple brakes.
- Precision wheel bearings.
- Excellent design and performance.
- Made in Australia.

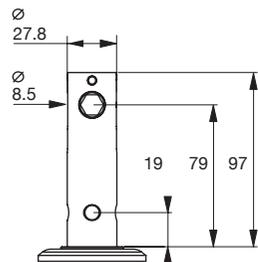

Long pintle
(Order code includes 'L')

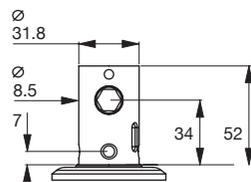

Short pintle
(Order code includes 'S'
and is made to order)



CUQ (twin wheel)
PU, precision bearing, thread guard

MJQ
TPE, precision bearing, thread guard

QTQ
Grey rubber, round profile, precision bearing, thread guard

Wheel	Max load (kg)	Bore (mm)	Diameter x tread (mm)
CUQ150GT	100	8	150 x 32
MJQ100G	100	8	100 x 32
MJQ125G	100	8	125 x 32
QTQ150G	100	8	150 x 32

Fork options

	Wheel diameter (mm)	Height (mm)	Turning radius (mm)
 CNL/CZL Long pintle with swivel	100	139	91
 CNLTB/CZLTB Long pintle with total brake	100	139	91
 CNLDL/CZLDL Long pintle with direction lock	100	139	91
 CNS/CZS Short pintle with swivel	100	139	91
 CNSTB/CZSTB Short pintle with total brake	100	139	91
 CNSDL/CZSDL Short pintle with direction lock	100	139	91
	125	165	103
	150	190	113

Order codes

Wheel code	Fork code	Castor code
CUQ150GT Diameter: 150 mm	C150NL	CUQ150GT/CNL
	C150NLTB	CUQ150GT/CNLTB
	C150NLDL	CUQ150GT/CNLDL
	C150NS	CUQ150GT/CNS
	C150NSTB	CUQ150GT/CNSTB
MJQ100G Diameter: 100 mm	C100ZL	MJQ100G/CZL
	C100ZLTB	MJQ100G/CZLTB
	C100ZLDL	MJQ100G/CZLDL
	C100ZS	MJQ100G/CZS
	C100ZSTB	MJQ100G/CZSTB
MJQ125G Diameter: 125 mm	C100ZSDL	CUQ150GT/CNSDL
	C125ZL	MJQ125G/CZL
	C125ZLTB	MJQ125G/CZLTB
	C125ZLDL	MJQ125G/CZLDL
	C125ZS	MJQ125G/CZS
QTQ150G Diameter: 150 mm	C125ZSTB	MJQ125G/CZSTB
	C125ZSDL	MJQ125G/CZSDL
	C150ZL	QTQ150G/CZL
	C150ZLTB	QTQ150G/CZLTB
	C150ZLDL	QTQ150G/CZLDL
MJQ125G Diameter: 125 mm	C150ZS	QTQ150G/CZS
	C150ZSTB	QTQ150G/CZSTB
	C150ZSDL	QTQ150G/CZSDL

Castor sets

Total brake (x2), direction lock (x2), transmission levers (x2).

CUQ150GT	Long pintle	CUQ150GTCLLSET
	Short pintle	CUQ150GTCLSSET
MJQ100G	Long pintle	MJQ100GCLLSET
	Short pintle	MJQ100GCLSSET
MJQ125G	Long pintle	MJQ125GCLLSET
	Short pintle	MJQ125GCLSSET
QTQ150G	Long pintle	QTQ150GCLLSET
	Short pintle	QTQ150GCLSSET

Central locking castors

Spare parts

Central locking castors must be installed with a tight fit into the tubing—otherwise the castors will tilt forward under load causing excessive wear and compromising the directional lock performance.

Our warranty only applies if castors are correctly installed. This includes always fitting the central locking castors using round tubing or square tubing with square adaptors.

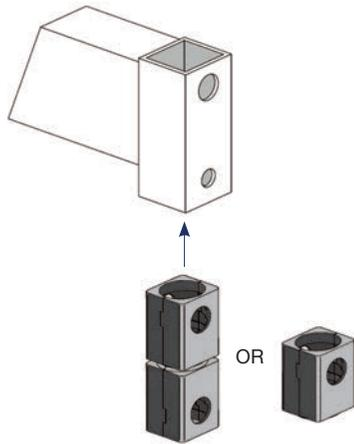

Fitting options order codes

Description	Order code
 Square adaptor to suit 28 mm ID tube	SPMCLNS28SPLIT
 Left hand side control pedal	SPPEDCL(L)
 Right hand side control pedal	SPPEDCL(R)
 Glass-filled nylon* transmission lever for long ISO pintle	SPMCLTL
 Glass-filled nylon* transmission lever to suit the short pintle	SPMCSTL

* Very strong, hard polymer designed for high abrasion resistance and ductility to prevent brittle-fracture. Note: Tougher than sintered metal transmission levers.

Central locking bed requirements

This page outlines the requirements needed to ensure that your Fallshaw central locking castors function correctly when initially fitted and also continue to function for the life of the product. If you are unable to meet one or more of these requirements please speak to our technical team to see if a special product can be made to suit your application.

Mounting heights

It is critical that the load of the bed sits on the mounting washer. This reduces movement of the product over time and reduces the stress placed on the attachment bolts and holes. If the load of the bed doesn't sit on the washer, with time the mounting bolt holes will elongate and the castor will push up into the leg and cease to function.

It is therefore important to control the height from the bottom of the tube to the attachment holes, and also to the hex bar hole (see drawing for dimension and tolerances). These dimensions are to suit the Australian and European Standard (EN12531:1999). If you are unable to meet these dimensions please speak to our sales team.

Hex bar clearance

It is also critical that the hex bar for actuating the castor is free to move. Ensure that the frame does not interfere with the hex bar. This involves either drilling large holes for ample clearance (suggest 18 mm diameter) or, if smaller holes are required. Ensure that all the holes are aligned and the frame is strong enough that it will not twist when fully loaded.

The hex bar should only contact the mechanism (two castors, pedals and the transmission lever), it should be able to rotate freely without rubbing or bending. If these holes are too small, or misaligned, the rubbing and bending of the hex bar will make operation difficult, and will stop the castors from functioning.

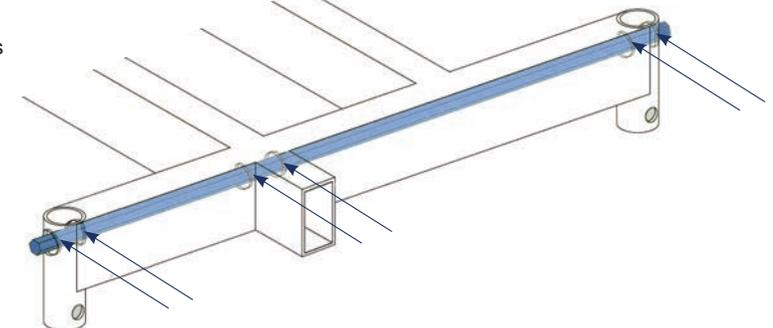
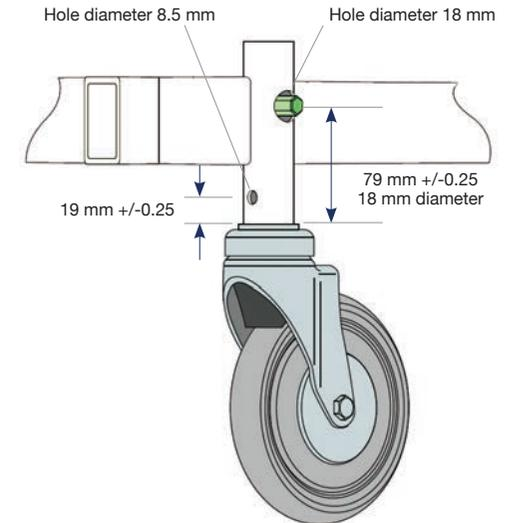

Conductive wheels



Features

- Conductive non-marking wheels exceeds the conductivity level requirements of ANSI/ESD S20.20-1999.
- Made in Australia.

Designed for use in Electrostatic Discharge (ESD) environments as part of an effective ESD Control Program, our conductive non-marking wheels can be assembled into our M series castors.

With a conductivity of $<10^6$, our conductive wheels exceed the requirements of ANSI/ESD S20.20-1999 for mobile equipment in protected areas, which specify 10^9 as the maximum level of resistance.

Installation of conductive wheels

Conductive wheels must be properly installed to ensure a conductive path from the trolley leg, through the stem, and the castor and the axle and the bearing, and through the centre and tyre. Solid metal pintles will provide such a conductive path. If plastic expanding stems are selected, they will need to be installed with a copper wire attached to the stem and wrapped between the adaptor and tube inner to ensure a conductive path.

Please note: Do not use with plastic expanding adaptors.

Wheel



MAQ*

Conductive TPE, precision bearing, thread guard

Forks



MZP

Plate with swivel

MZPTB

Plate with swivel & total brake

MZPDL

Plate with swivel & direction lock

MZF

Fixed plate, no swivel



MZH

Bolt hole swivel

MZHTB

Bolt hole swivel & total brake

MZHDL

Bolt hole swivel & direction lock

Fork options

Fork	Wheel size (mm)	Mount height (mm)	Turning radius (mm)
MZP/MZH/MZF ⁴	75	106	71
	100	135	91
	125	161	103
MZPTB/MZPDL/MZHTB/MZHDL	75	106	118
	100	135	128
	125	161	128

* See page 14 for M Series fork options. Also available with stainless steel bearing "MAC" for M Powder-coat (page 52) and M Stainless Steel (page 48) castors.

Wheel options

Wheel	Max load (kg)	Diameter x tread (mm)	Hub x bore (mm)	Bore—no bush (mm)
MAQ75G	85	75 x 32	40 x 8	8
MAQ100G	85	100 x 32	40 x 8	8
MAQ125G	85	125 x 32	40 x 8	8

Order codes

Wheel	Fork	Castor
MAQ75G	M75ZP	MAQ75G/MZP
	M75ZPTB	MAQ75G/MZPTB
	M75ZPDL	MAQ75G/MZPDL
	M75ZF	MAQ75G/MZF
	M75ZH	MAQ75G/MZH
	M75ZHTB	MAQ75G/MZHTB
	M75ZHDL	MAQ75G/MZHDL
MAQ100G	M100ZP	MAQ100G/MZP
	M100ZPTB	MAQ100G/MZPTB
	M100ZPDL	MAQ100G/MZPDL
	M100ZF	MAQ100G/MZF
	M100ZH	MAQ100G/MZH
	M100ZHTB	MAQ100G/MZHTB
	M100ZHDL	MAQ100G/MZHDL
MAQ125G	M125ZP	MAQ125G/MZP
	M125ZPTB	MAQ125G/MZPTB
	M125ZPDL	MAQ125G/MZPDL
	M125ZF	MAQ125G/MZF
	M125ZH	MAQ125G/MZH
	M125ZHTB	MAQ125G/MZHTB
	M125ZHDL	MAQ125G/MZHDL

Fork mounts

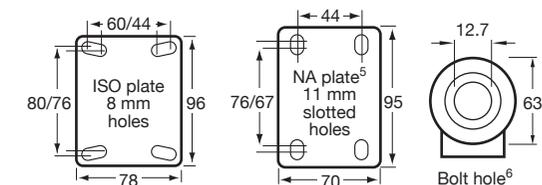

Wheelchair castors



Features

- High impact nylon moulded centre with foamed urethane tyre and precision bearing.
- Spoked design for lighter castor weight, only 0.3 kg for 150 mm castor, 0.44 kg for 175 mm castor, and 0.55 kg for the 200 mm castor.
- Maintenance free sealed precision head race bearing.
- Not available with brakes.
- Made in Australia.



CFQ

Foamed urethane wheel, precision bearing, no thread guard.

Wheel options

Wheel	Max load (kg)	Weight (kg)	Diameter x tread (mm)	Hub x bore (mm)
CFQ150*	45	0.30	150 x 35	40 x 8
CFQ175	45	0.44	175 x 45	50 x 8
CFQ200	45	0.55	200 x 45	50 x 8

Solid stem pintle mount

Stem OD	Tube size (OD x wall thickness)	Cross drill hole (distance from end x diameter)	Order code
19 mm round	22 x 1.2 mm		19 x 8 mm -AR19Z
22 mm round	25 x 1.6 mm		19 x 8 mm -AR22Z
-AR19 with adaptor 22 mm square. (Supplied as 19 mm round solid stem with 22 mm square nylon overlay.)	25 x 1.6 mm SQ		19 x 8 mm -AS22Z
28 mm round	32 x 1.6 mm		19 x 8 mm -AR28Z

* Note: CFQ150 wheel can be used with Big M forks for additional combinations.

Fork options

Forks	Wheel size (mm)	Mount height (mm)	Turning radius (mm)
M150ZH	150	187	153
C175PH	175	225	130
C200PH	200	237	144

Order codes

Wheel	Fork code	Castor code
CFQ150	M150ZH	CFQ150/MZH
CFQ175	C175PH	CFQ175/CPH
CFQ200	C200PH	CFQ200/CPH



See the Bariatric Wheelchair Mover on page 91

Specialised castors

M & O Stainless steel castors

Our stainless steel castors are the premium castors for corrosive environments. 100% corrosion free, with a wide range of styles and load capacities available.

M Powder-coat castors

Specially designed for corrosive environments (particularly shower chair applications). Zinc plated and then powder-coated for better corrosion resistance from substances such as alkaline soaps and other cleaning agents, these castors have stainless steel bottom races and twin ball races with stainless steel balls, covered by a diaphragm shroud to stop water entering from above). The wheels are available with a plain PBT (corrosion free) bush or a stainless steel precision bearing with thread guards to prevent the build-up of hair and lint.

High & low temperature castors

While our standard wheels and castors have a working temperature range of 5°C to 60°C, we also make specialised high temperature castors designed to withstand temperatures of baking ovens, and low temperature castors that can survive in freezing rooms.

Self-aligning castors

Self-aligning castors for Automated Guided Vehicle (AGV) carts ensure that the castors align with the AGV's direction of travel when it is lifted off the ground. This ensures that the castor avoids coming into contact with walls, pedestrians or the AGV itself.

Supermarket trolley and travelator castors

Our range of castors designed for supermarket trolleys and travelators are built for reliability and safety.

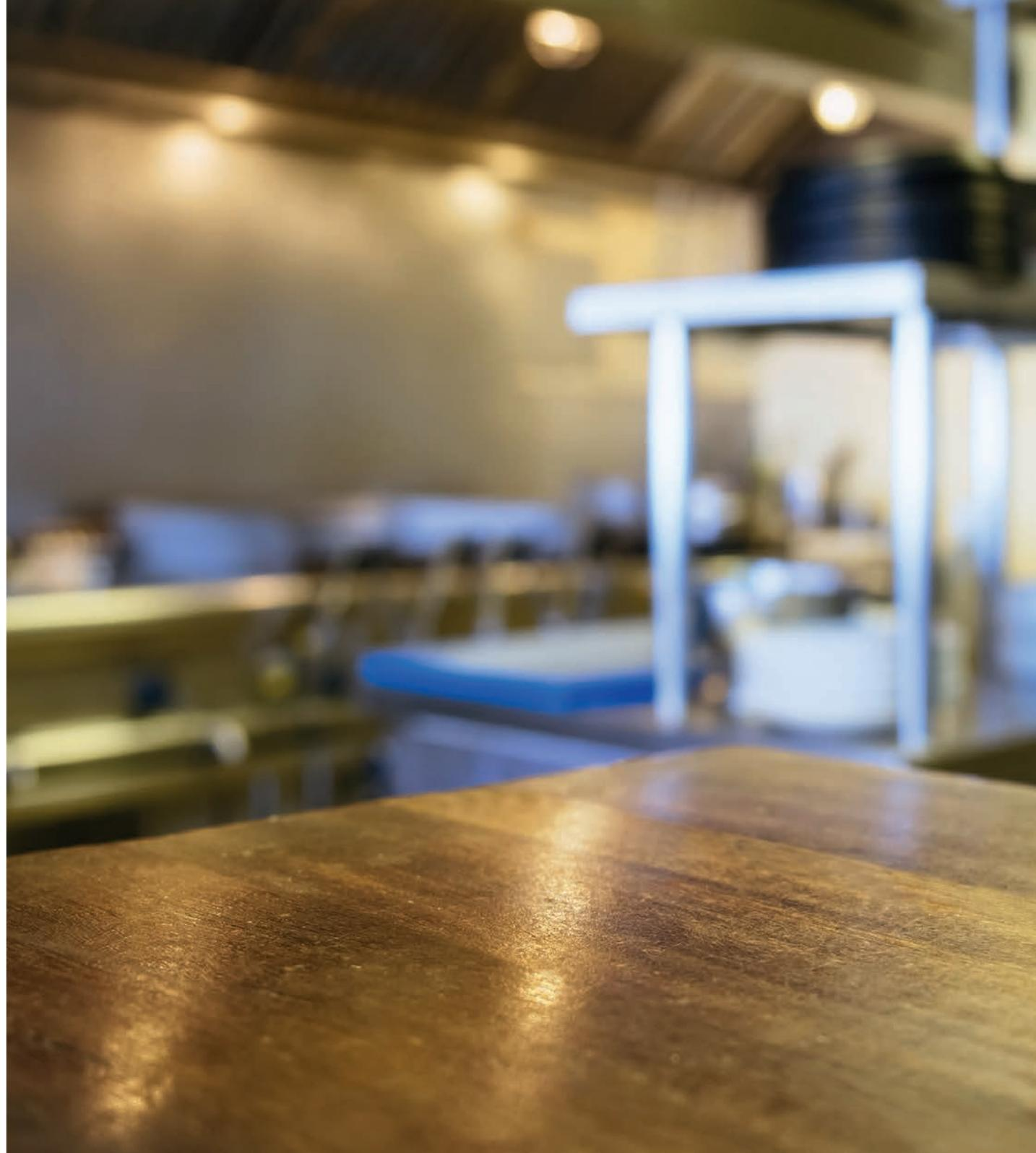

M Stainless



Features

- 100% corrosive-free 304 grade stainless steel (SS) castors in plate or bolt hole configurations, with or without total brake or direction lock.
- M Series thermoplastic elastomer (TPE), white nylon, grey rubber, or polyurethane (PU) on polypropylene (PP) wheels with stainless steel (SS) bearings or stainless steel bushes.
- Standard Chicago screw axles².
- Chicago screw axle type 304.
- Fork and ball bearings type 304.
- Axle, bolt and nut type 304.
- Rivet and axle bush type 303.
- TB spring type 301 full hard.
- Magnetic and high carbon stainless steel precision bearings type AISI440C.
- Option for regular nut and bolt or stainless steel Chicago screw.
- Made in Australia.

See page 47 for more information about chemical resistance.

Wheels



MJC*
TPE, SS precision bearing, thread guard



MNN...WS
White nylon, plain bearing



DNC⁵
White nylon, SS precision bearing



MSC¹
Grey rubber, SS precision bearing, thread guard



QUC¹
PU on PP, SS precision bearing, thread guard

Forks



MSP
Plate with swivel



MSPTB
Plate with swivel and total brake



MSPDL
Plate with swivel and direction lock



MSF
Fixed plate, no swivel



MSH
Bolt hole swivel



MSHTB
Bolt hole swivel and total brake



MSHDL
Bolt hole swivel and direction lock

Wheel	Max load (kg)	Diameter x tread (mm)	Hub x bore (mm)	Bore—no bush (mm)	Forks ²	Wheel size (mm)	Mount height (mm)	Turning radius (mm)
MJC75G	85	75 x 32	40 x 8	8	MSP/MSH/MSF ³	75	106	71
MJC100G	85	100 x 32	40 x 8	8		100	135	91
MJC125G	85	125 x 32	40 x 8	8		125	161	103
MNN75WS	150	75 x 32	40 x 8	12	MSPTB/MSPDL/MSHTB/MSHDL	75	106	118
MNN100WS	150	100 x 32	40 x 8	12		100	135	128
MNN125WS	150	125 x 32	40 x 8	12		125	161	128
DNC100W ⁵	200	100 x 32	40 x 8	8	Fork mounts			
DNC125W	200	125 x 32	40 x 8	8				
MSC100G	140	100 x 34	40 x 8	8				
MSC125G	150	125 x 34	40 x 8	8				
QUC75G	200	75 x 32	40 x 8	8				
QUC100G	200	100 x 32	40 x 8	8				
QUC125G	200	125 x 32	40 x 8	8				

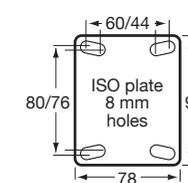

* Wheel also available in conductive—MAC, or plain bearing—MJA.

¹ Wheels also available with plain bearings—MSA, QUA.

² To replace Chicago screw axles with regular hex bolt axles, add **-B** to the end of fork code.

³ MSF—fixed plate has no turning radius.

⁴ Bushes available to reduce bolt hole to 8 and 10 mm (see page 69).

⁵ DNC100W are made to order.

Order codes

Wheel	Fork code	Castor code
DNC125W	M125SP	DNC125W/MSP
	M125SPTB	DNC125W/MSPTB
	M125SPDL	DNC125W/MSPDL
	M125SF	DNC125W/MSF
	M125SH	DNC125W/MSH
	M125SHTB	DNC125W/MSHTB
M125SHDL	DNC125W/MSHDL	
MJC75G	M75SP	MJC75G/MSP
	M75SPTB	MJC75G/MSPTB
	M75SPDL	MJC75G/MSPDL
	M75SF	MJC75G/MSF
	M75SH	MJC75G/MSH
	M75SHTB	MJC75G/MSHTB
M75SHDL	MJC75G/MSHDL	
MJC100G	M100SP	MJC100G/MSP
	M100SPTB	MJC100G/MSPTB
	M100SPDL	MJC100G/MSPDL
	M100SF	MJC100G/MSF
	M100SH	MJC100G/MSH
	M100SHTB	MJC100G/MSHTB
M100SHDL	MJC100G/MSHDL	
MJC125G	M125SP	MJC125G/MSP
	M125SPTB	MJC125G/MSPTB
	M125SPDL	MJC125G/MSPDL
	M125SF	MJC125G/MSF
	M125SH	MJC125G/MSH
	M125SHTB	MJC125G/MSHTB
M125SHDL	MJC125G/MSHDL	
MNN75WS	M75SP	MNN75WS/MSP
	M75SPTB	MNN75WS/MSPTB
	M75SPDL	MNN75WS/MSPDL
	M75SF	MNN75WS/MSF
	M75SH	MNN75WS/MSH
	M75SHTB	MNN75WS/MSHTB
M75SHDL	MNN75WS/MSHDL	

Wheel	Fork code	Castor code
MNN100WS	M100SP	MNN100WS/MSP
	M100SPTB	MNN100WS/MSPTB
	M100SPDL	MNN100WS/MSPDL
	M100SF	MNN100WS/MSF
	M100SH	MNN100WS/MSH
	M100SHTB	MNN100WS/MSHTB
M100SHDL	MNN100WS/MSHDL	
MNN125WS	M125SP	MNN125WS/MSP
	M125SPTB	MNN125WS/MSPTB
	M125SPDL	MNN125WS/MSPDL
	M125SF	MNN125WS/MSF
	M125SH	MNN125WS/MSH
	M125SHTB	MNN125WS/MSHTB
M125SHDL	MNN125WS/MSHDL	
MSC100G	M100SP	MSC100G/MSP
	M100SPTB	MSC100G/MSPTB
	M100SPDL	MSC100G/MSPDL
	M100SF	MSC100G/MSF
	M100SH	MSC100G/MSH
	M100SHTB	MSC100G/MSHTB
M100SHDL	MSC100G/MSHDL	
MSC125G	M125SP	MSC125G/MSP
	M125SPTB	MSC125G/MSPTB
	M125SPDL	MSC125G/MSPDL
	M125SF	MSC125G/MSF
	M125SH	MSC125G/MSH
	M125SHTB	MSC125G/MSHTB
M125SHDL	MSC125G/MSHDL	
QUC75G	M75SP	QUC75G/MSP
	M75SPTB	QUC75G/MSPTB
	M75SPDL	QUC75G/MSPDL
	M75SF	QUC75G/MSF
	M75SH	QUC75G/MSH
	M75SHTB	QUC75G/MSHTB
M75SHDL	QUC75G/MSHDL	

Wheel	Fork code	Castor code
QUC100G	M100SP	QUC100G/MSP
	M100SPTB	QUC100G/MSPTB
	M100SPDL	QUC100G/MSPDL
	M100SF	QUC100G/MSF
	M100SH	QUC100G/MSH
	M100SHTB	QUC100G/MSHTB
M100SHDL	QUC100G/MSHDL	
QUC125G	M125SP	QUC125G/MSP
	M125SPTB	QUC125G/MSPTB
	M125SPDL	QUC125G/MSPDL
	M125SF	QUC125G/MSF
	M125SH	QUC125G/MSH
	M125SHTB	QUC125G/MSHTB
M125SHDL	QUC125G/MSHDL	



Pictured: M Stainless steel castor with optional buffer cap (available separately).

O Stainless



Features

- 100% corrosive-free 304 grade stainless steel (SS) castors in plate or bolt hole configurations, with or without total brake or direction lock.
- Blue high resilience (hi-res) rubber, grey rubber, polyurethane (PU) or white nylon wheels.
- Chicago screw axle type 304.
- Fork and ball bearings type 304.
- Axle, bolt and nut type 304.
- Rivet and axle bush type 303.
- TB spring type 301 full hard.
- Reducing bush type 303.
- Option for regular nut and bolt or stainless steel Chicago screw.
- Made in Australia.

See page 47 for more information about chemical resistance.

Wheels



HBS*¹

Blue hi-res rubber, SS roller bearing

HSS*¹

Grey rubber, SS roller bearing, optional thread guard

HUS*

PU, SS roller bearing

ONS...W*

White nylon, SS roller bearing

Wheel	Max load (kg)	Diameter x tread (mm)	Hub x bore (mm)	Bore—no bush (mm)
HBS150	230	150 x 28	60 x 12.7	20
HBS200	250	200 x 28	60 x 12.7	20
HSS200	250	200 x 50	60 x 12.7	20
HUS100	400	100 x 40	60 x 12.7	20
HUS125	400	125 x 40	60 x 12.7	20
HUS150	450	150 x 40	60 x 12.7	20
HUS200	500	200 x 48	60 x 12.7	20
ONS100W	350	100 x 40	60 x 12.7	20
ONS125W	380	125 x 40	60 x 12.7	20
ONS150W	450	150 x 40	60 x 12.7	20
ONS200W	500	200 x 40	60 x 12.7	20

* Wheels also available with plain bearings—HBA, HSA, HUA...S, ONA...WS.

¹ HBS, HSS wheels are not compatible with total brake fork.

Forks



OSP

Plate with swivel

OSPTB¹

Plate with swivel and total brake

OSPDL

Plate with swivel and direction lock

HSF

Fixed plate

Forks	Wheel size (mm)	Mount height (mm)	Turning radius (mm)
OSP/HSF ²	100	138	96
	125	162	109
	150	189	121
	200	239	152
OSPTB/OSPDL	100	138	140
	125	162	140
	150	189	140
	200	239	162

Fork mounts

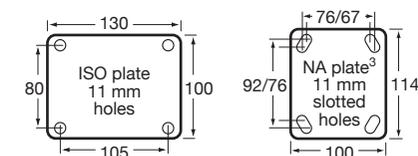

² HSF—fixed plate has no turning radius.

³ North American plate. Add **N** to the end of fork code to purchase (eg. HBS150/OSPNTB).

Order codes

Wheel	Fork code	Castor code
HBS150 Diameter: 150 mm	O150SP	HBS150/OSP
	H150SF	HBS150/HSF
	O150SPDL	HBS150/OSPDL
HBS200 Diameter: 200 mm	O200SP	HBS200/OSP
	H200SF	HBS200/HSF
	O200SPDL	HBS200/OSPDL
HSS200² Diameter: 200 mm	O200SP	HSS200/OSP
	H200SF	HSS200/HSF
	O200SPDL	HSS200/OSPDL
HUS100 Diameter: 100 mm	O100SP	HUS100/OSP
	H100SF	HUS100/HSF
	O100SPTB	HUS100/OSPTB
	O100SPDL	HUS100/OSPDL
HUS125 Diameter: 125 mm	O125SP	HUS125/OSP
	H125SF	HUS125/HSF
	O125SPTB	HUS125/OSPTB
	O125SPDL	HUS125/OSPDL
HUS150 Diameter: 150 mm	O150SP	HUS150/OSP
	H150SF	HUS150/HSF
	O150SPTB	HUS150/OSPTB
	O150SPDL	HUS150/OSPDL
HUS200 Diameter: 200 mm	O200SP	HUS200/OSP
	H200SF	HUS200/HSF
	O200SPTB	HUS200/OSPTB
	O200SPDL	HUS200/OSPDL

Wheel	Fork code	Castor code
ONS100W Diameter: 100 mm	O100SP	ONS100W/OSP
	H100SF	ONS100W/HSF
	O100SPTB	ONS100W/OSPTB
	O100SPDL	ONS100W/OSPDL
ONS125W Diameter: 125 mm	O125SP	ONS125W/OSP
	H125SF	ONS125W/HSF
	O125SPTB	ONS125W/OSPTB
	O125SPDL	ONS125W/OSPDL
ONS150W Diameter: 150 mm	O150SP	ONS150W/OSP
	H150SF	ONS150W/HSF
	O150SPTB	ONS150W/OSPTB
	O150SPDL	ONS150W/OSPDL
ONS200W Diameter: 200 mm	O200SP	ONS200W/OSP
	H200SF	ONS200W/HSF
	O200SPTB	ONS200W/OSPTB
	O200SPDL	ONS200W/OSPDL



M Powder-coat



Features

- Powder-coated zinc plated bolt hole forks with or without total brake or direction lock in Interpon Anodic Natural Matte colour.
- M Series thermoplastic elastomer (TPE), white nylon, grey rubber, or polyurethane (PU) on polypropylene (PP) wheels with stainless steel (SS) bearings or stainless steel bushes.
- Resistant to corrosion from alkaline soaps and cleaning agents, making them suitable for shower chairs and similar applications.
- Twin ball race with stainless steel balls covered with a buffer (five sizes available) to lock out water.
- Stainless steel bottom race and brake rivet.
- Powder-coat colour Anodic Natural Matte.
- Medical Trinity™ red colourway pedal.
- Stainless steel screw (domed head axle).
- 1 year warranty in shower chair applications.
- 3 year warranty in general use (subject to conditions of use).
- Can be fitted with M12 pintle bolts with expanding adaptors or solid pintles.
- Made in Australia.

Wheels



MJC*
TPE, SS precision bearing, thread guard



MNN...W
White nylon, plain bearing



DNC
White nylon, SS precision bearing



QTC¹
Grey rubber, SS precision bearing, thread guard



MSC¹
Grey rubber, SS precision bearing, thread guard



QUC¹
PU on PP, SS precision bearing, thread guard



MPH
Bolt hole swivel



MPHTB
Bolt hole swivel and total brake



MPHDL
Bolt hole swivel and direction lock

Forks

Wheel	Max load (kg)	Diameter x tread (mm)	Hub x bore (mm)	Bore—no bush (mm)
MJC125G	85	125 x 32	40 x 8	8
MNN125W	150	125 x 32	40 x 8	12
DNC125	200	125 x 32	40 x 8	8
QTC150G	150	150 x 34	40 x 8	8
QTC175G	150	175 x 34	40 x 8	8
MSC125G	150	125 x 34	40 x 8	8
QUC125G	200	125 x 32	40 x 8	8

Forks	Wheel size (mm)	Mount height (mm)	Turning radius (mm)
MPH	125	161	103
	150	187	130
	175	214	145
MPHTB/MPHDL	125	161	128
	150	187	153
	175	214	153

Fork mounts

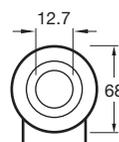

Bolt hole²

Buffer options



-BUF22: Suit -ER19 or -AR19

-BUF25: Suit -ER22 or -AR22

-BUF28: Suit-ER28 or -AR28

-BUF32: Suit 33 mm OD of hollow stem

-BUF33.5: Suit 34 mm OD of hollow stem

Buffer caps are optional extras, available to purchase separately. See page 73 for more information.

Order codes

Wheel code	Fork code	Castor code
DNC125	M125PH	DNC125/MPH
	M125PHTB	DNC125/MPHTB
	M125PHDL	DNC125/MPHDL
MJC125G	M125PH	MJC125G/MPH
	M125PHTB	MJC125G/MPHTB
	M125PHDL	MJC125G/MPHDL
MNN125W	M125PH	MNN125W/MPH
	M125PHTB	MNN125W/MPHTB
	M125PHDL	MNN125W/MPHDL
MSC125G	M125PH	MSC125G/MPH
	M125PHTB	MSC125G/MPHTB
	M125PHDL	MSC125G/MPHDL
QTC150G	M150PH	QTC150G/MPH
	M150PHTB	QTC150G/MPHTB
	M150PHDL	QTC150G/MPHDL
QTC175G	M175PH	QTC175G/MPH
	M175PHTB	QTC175G/MPHTB
	M175PHDL	QTC175G/MPHDL
QUC125G	M125PH	QUC125G/MPH
	M125PHTB	QUC125G/MPHTB
	M125PHDL	QUC125G/MPHDL

* Wheel also available in conductive—MAC, or plain bearing—MJA.

¹ Wheels also available with plain bearings—QTA, MSA, QUA.

² Bushes available to reduce bolt hole to 8 and 10 mm (see page 69).

About high and low temperature castors

The normal temperature limit of our standard wheels and castors is 5°C to 60°C (41°F to 140°F). For applications outside these temperatures, please see below.

High temperature use

As temperatures increase, wheels become weaker, which lowers their load capacity and shortens their lifespan. It is important that you specify the temperature and type of application before ordering a castor, to ensure that the appropriate wheel type is selected. We make three different wheel types designed specifically for use in high temperature environments. These specialised wheels use standard lithium complex grease (STABUTHERM® GH 461) which has excellent water resistance (24 hrs at 90°C), bearing retention and long life.

Low temperature use

Below 5°C you must specify temperature of use at the time of ordering. The standard grease we use in our castors is a lithium complex grease (AERO SHELL7 GREASE MIL-PRF-23827C Type II 70149). This has excellent water resistance, bearing retention and long life. However below 5°C it begins to stiffen quickly, and will soon freeze the bearings so that neither the castor swivels nor the wheel bearings revolve. If specified at the time of ordering, we use a special aeronautical grease which is a synthetic oil with a microgel thickener. This is compounded for use down to -30°C, and will need to be refreshed every 6–12 months, but will continue to work effectively in chilling rooms, freezing stores and outdoor winter use in northern countries where ordinary greases would be useless.

As the temperature becomes lower, the softer rubber and polyurethane treads on our wheels become less elastic. For example, the polyurethane used on the 'H' series slowly stiffens from +20°C down to -20°C, but then rapidly stiffens until at -50°C, when it becomes brittle.

As temperature goes below 5°C, nylon can become brittle (particularly if it is kept for long periods in the very dry air in freezing rooms). At such times we recommend glass filled nylon reinforced wheels, which can be used down to -30°C.

Note: Grease nipples can be added to the wheel and fork using order codes SPGNIPPLEW (to add to the wheel) or SPGNIPPLEF (to add to the fork). High or low temperature grease can be added to stainless steel castors using spare part order codes: SPLOWTEMPGREASE or SPHTEMPGREASE.



Castors for applications such as baking trolleys and freezer carts need to be specified to ensure that they perform optimally in these extreme conditions.



Wheel types

Glass filled nylon

The best choice for hospitality based applications such as 'food baking' ovens, glass filled nylon can withstand sustained high temperatures and is gentle and quiet on most floor surfaces. Fibreglass reinforced nylon wheels are the preferred wheel for extended periods of up to 210°C (assuming most of their life is spent outside the oven), and for short periods up to 230°C.

Phenolic

Phenolic is more brittle than glass filled nylon and it has a shorter life cycle but can go up to very high temperatures. Phenolic is a good choice for light duty industrial applications with very high temperatures such as ovens used for curing paint. The load capacity decreases from 125 kg at 100°C to 40 kg at 300°C therefore it is very important to ensure that the load capacity of the trolley fits within the appropriate temperature and load capacity. Phenolic wheels (with special inorganic fillers and PTFE bushes) are preferred for extended periods up to 280°C assuming most of their life is spent outside the oven and for short periods up to 300°C. These have a thick cross section, but are more brittle than either nylon or ordinary grades of phenolic.

Please note that phenolic wheels are not suitable for medium duty applications or applications where wheels are subjected to impact such as when a trolley is rolled down steps.

Cast iron

The best choice for Industrial based applications such as 'paint curing' ovens and also for use in sustained high temperature environments, cast iron wheels can withstand extreme high temperatures as well as higher load capacities than all other wheel types. Cast iron wheels do not have bearings. They have a plain bore fitted with an axle spacer that is lubricated with high temperature grease. This grease can be used up to 230°C for long periods. For temperatures that exceed 230°C a more exotic grease is required. For sustained high temperature use, we offer a range of cast iron wheeled castors used with high temperature grease. Please note that cast iron is heavy, noisy and may damage concrete floors and other floor surfaces.

See page 54 for our range of high and low temperature castors.

High & low temperature castors



Features

- Available with high temperature resistant phenolic, or cast iron wheels, and freeze resistant glass reinforced nylon.
- Swivel, fixed plate or bolt hole zinc plated Core Coat™ forks.
- Core Coat™ lacquer provides best quality corrosion protection, with no white or red rust after 150 hours of salt spray testing.
- Specialised castor and fork grease depending on application.
- Made in Australia.

Detailed information about high and low temperature castors, including typical applications are available on page 53.

M Series wheels



MHH

Glass reinforced nylon, lighter hub, plain bearing



MKT

High temperature phenolic, plain bearing



DCI

Cast iron, plain bearing

Wheel	Max load at temperature	Diameter x tread (mm)	Hub x bore (mm)	Bore—no bush (mm)
MHH75*	70 kg at 150°C	75 x 32	41 x 8	12
MHH100*	80 kg at 150°C 70 kg at 180°C 60 kg at 210°C 50 kg at 230°C*	100 x 32	41 x 8	12
MKT100	125 kg at 100°C 100 kg at 250°C 40 kg at 300°C	100 x 35	41 x 8	12
DCI75	100 kg at 400°C	75 x 28	41 x 8	12

M Series forks



Plate with swivel¹

High temp—MZPHT
Low temp—MZPLT



Fixed plate²

High temp—MZFHT
Low temp—MZF



Bolt hole swivel

High temp—MZHHT
Low temp—MZHLT

Fork	Wheel size (mm)	Mount height (mm)	Turning radius (mm)
MZPHT/MZPLT	75	106	71
MZFHT/MZF ³	100	135	91
MZHHT/MZHLT			

* MHH wheel should be exposed to this temperature for short periods only.

¹ Also available with North American plate with swivel—MZPNHT, MZPNLT.

² Also available with North American fixed plate—MZFNHT, MZFN.

³ Fixed plate has no turning radius.

J Series wheels



JHH

Glass reinforced nylon, heavy hub, plain bearing



JCI

Cast iron, plain bearing

Wheel	Max load at temperature	Diameter x tread (mm)	Hub x bore (mm)	Bore—no bush (mm)
JHH100	100 kg at 150°C 90 kg at 180°C 80 kg at 210°C 60 kg at 230°C*	100 x 32	45 x 10	20
JCI100	230 kg at 400°C	100 x 38	45 x 10	20

J Series forks



Plate with swivel

High temp—JZPHT
Low temp—JZPLT



Fixed plate

High temp—JZFHT
Low temp—JZF



Bolt hole swivel

High temp—JZHHT
Low temp—JZHLT

Fork	Wheel size (mm)	Mount height (mm)	Turning radius (mm)
JZPHT/JZPLT	100	129	90
JMZFHT/JZF ¹			
JZHHT/JZHLT			

* JHH wheel should be exposed to this temperature for short periods only.

¹ Fixed plate has no turning radius.

Please note:

- High temperature castors cannot be supplied with brakes.
- LT = Low temperature (below 5°C).
- HT = High temperature (above 60°C).

O Series wheels



OHH
Glass reinforced nylon, heavy hub, plain bearing



WCI
Cast iron, plain bearing

Wheel	Max load at temperature	Diameter x tread (mm)	Hub x bore (mm)	Bore—no bush (mm)
OHH150	200 kg at 210°C	150 x 40	60 x 12.7	20
WCI150	250 kg at 400°C	150 x 50	60 x 12.7	20

O Series forks



Plate with swivel*
High temp—OZPHT
Low temp—OZPLT



Fixed plate¹
High temp—HZFHT
Low temp—HZF

Fork	Wheel size (mm)	Mount height (mm)	Turning radius (mm)
OZPHT/OZPLT HZFHT/HZF ²	150	189	121

* Also available with North American plate with swivel—OZPNHT, OZPNLT.

¹ Also available with North American fixed plate—HZFNHT, HZFN.

² Fixed plate has no turning radius

Order codes

M Series wheels	Fork code	Castor code
DCI75 High temp	M75ZPHT	DCI75/MZPHT
	M75ZPNHT	DCI75/MZPNHT
	M75ZFHT	DCI75/MZFHT
	M75ZFNHT	DCI75/MZFNHT
	M75ZHHT	DCI75/MZHHT
MHH75 High temp	M75ZPHT	MHH75/MZPHT
	M75ZPNHT	MHH75/MZPNHT
	M75ZFHT	MHH75/MZFHT
	M75ZFNHT	MHH75/MZFNHT
	M75ZHHT	MHH75/MZHHT
MHH100 High temp	M100ZPHT	MHH100/MZPHT
	M100ZPNHT	MHH100/MZPNHT
	M100ZFHT	MHH100/MZFHT
	M100ZFNHT	MHH100/MZFNHT
	M100ZHHT	MHH100/MZHHT
MHH100 Low temp	M100ZPLT	MHH100/MZPLT
	M100ZPNLT	MHH100/MZPNLT
	M100ZF	MHH100/MZF
	M100ZFN	MHH100/MZFN
	M100ZHLT	MHH100/MZHLT
MKT100 High temp	M100ZPHT	MKT100/MZPHT
	M100ZPNHT	MKT100/MZPNHT
	M100ZFHT	MKT100/MZFHT
	M100ZFNHT	MKT100/MZFNHT
	M100ZHHT	MKT100/MZHHT

J Series wheels	Fork code	Castor code
JCI100 High temp	J100ZPHT	JCI100/JZPHT
	J100ZFHT	JCI100/JZFHT
	J100ZHHT	JCI100/JZHHT
JCI100 Low temp	J100ZPLT	JCI100/JZPLT
	J100ZF	JCI100/JZF
	J100ZHLT	JCI100/JZHLT

J Series wheels	Fork code	Castor code
JHH100 High temp	J100ZPHT	JHH100/JZPHT
	J100ZFHT	JHH100/JZFHT
	J100ZHHT	JHH100/JZHHT
JHH100 Low temp	J100ZPLT	JHH100/JZPLT
	J100ZF	JHH100/JZF
	J100ZHLT	JHH100/JZHLT
O Series wheels	Fork code	Castor code
OHH150 High temp	O150ZPHT	OHH150/OZPHT
	O150ZPNHT	OHH150/OZPNHT
	H150ZFHT	OHH150/HZFHT
OHH150 Low temp	H150ZFNHT	OHH150/HZFNHT
	O150ZPLT	OHH150/OZPLT
	O150ZPNLT	OHH150/OZPNLT
OHH150 Low temp	H150ZF	OHH150/HZF
	H150ZFN	OHH150/HZFN
	WCI150 High temp	O150ZPHT
O150ZPNHT		WCI150/OZPNHT
H150ZFHT		WCI150/HZFHT
H150ZFNHT		WCI150/HZFNHT
WCI150 Low temp	O150ZPLT	WCI150/OZPLT
	O150ZPNLT	WCI150/OZPNLT
	H150ZF	WCI150/HZF
	H150ZFN	WCI150/HZFN

Self-aligning castors

Available with a selection of wheels from the M, Big M and O Series, with stainless steel (SS) or zinc* forks, self-aligning castors are available with swivel plate or total brake configurations.

For carts that require narrower castors, self-aligning castors can also be made in a special ultra-slim M Series with a 61.5 mm barrel width. Contact a sales representative for more details.

Self-aligning castors are not a stocked item due to highly variable demand. Manufactured to order.

Features

- Suitable for Automated Guided Vehicle (AGV) carts.
- Stainless steel or zinc plated Core Coat™ forks.
- Wide selection of wheels from M, Big M and O Series.
- Available with or without total brake.
- Made in Australia.

Forks

M/Big M Series	Wheel diameter (mm)	Height (mm)	Turning radius (mm)
 MSPSA (SS) ⁹	125	161	103
	 MZPSA (Zinc)	150	187
Plate with swivel			
 MSPTBSA (SS with total brake) ⁹	125	161	128
	 MZPTBSA (Zinc with total brake)	150	187
Fixed plate			
 MSF (SS)	125	161	-
	 MZF (Zinc)	150	187
Fixed plate			
 MZHSA** (Zinc)	125	161	128
	 MZHTBSA** (Zinc with total brake)	150	187
Bolt hole swivel			
 MZHTBSA** (Zinc with total brake)	125	161	128
	150	187	153

O Series ⁵	Wheel diameter (mm)	Height (mm)	Turning radius (mm)	
 OSPZA (SS)	125	162	109	
	 OZPSA (Zinc*)	150	189	121
		200	239	152
Plate with swivel				
 OSPTBSA (SS with total brake)	125	162	140	
	 OZPTBSA (Zinc with total brake*)	150	189	140
200		239	162	
Fixed plate				
 HSF (SS)	125	162	-	
	 HZF (Zinc*)	150	189	-
200		239	-	

Wheel compatibility

M Series ¹	Max load (kg)	O Series	Max load (kg)
MJQ125G	85	HBS150³	230
CBQ125G	100	HBS200³	250
STQ125G	100	HSR200³	250
MBQ125G	150	HUR150³	450
MNN125	150	HUR200	500
MSQ125G	150	OBQ125⁴	350
DNQ125G	200	OBQ150⁴	400
QUQ125G	200	OBQ200⁴	400
Big M Series ²		ONR125	400
QTQ150G	200	ONR150	450
		ONR200	500

* Minimum order quantity of 200 pieces for O Series zinc Core Coat™ castors.

** Any pintle bolt used to install a bolt hole self-aligning castor must have a bolt head thickness of less than or equal to 4.6 mm (eg. SPM12X65THINHEAD).

¹ See page 14 for more information on compatible 125 mm M Series wheels.

² See page 17 for more information on Big M Series wheels.

³ For optional thread guards, add **G** to the end of wheel code.

⁴ Also available with SS precision bearing—OBC125, OBC150, OBC200.

⁵ See page 22 for more information on O Series wheels.

⁶ See page 157 for M and Big M Series ISO and NA fork mount plate diagrams.

⁷ Also available in SS—MSPSA, MSPTBSA, MSF.

⁸ See page 157 for O Series ISO and NA fork mount plate diagrams.

Also available in zinc Core Coat™—OZPSA, HZF, OZPTBSA.

⁹ MSPSA, MSPTBSA are not available in 150 mm stainless steel forks.



Order codes

M Series wheels	Fork code	Castor code
CBQ125G	M125SPSA ⁷	CBQ125G/MSPSA ⁷
	M125SPTBSA ⁷	CBQ125G/MSPTBSA ⁷
	M125SF ⁷	CBQ125G/MSF ⁷
	M125ZHSA	CBQ125G/MZHSA
	M125ZHTBSA	CBQ125G/MZHTBSA
DNQ125	M125SPSA ⁷	DNQ125/MSPSA ⁷
	M125SPTBSA ⁷	DNQ125/MSPTBSA ⁷
	M125SF ⁷	DNQ125/MSF ⁷
	M125ZHSA	DNQ125/MZHSA
	M125ZHTBSA	DNQ125/MZHTBSA
MBQ125G	M125SPSA ⁷	MBQ125G/MSPSA ⁷
	M125SPTBSA ⁷	MBQ125G/MSPTBSA ⁷
	M125SF ⁷	MBQ125G/MSF ⁷
	M125ZHSA	MBQ125G/MZHSA
	M125ZHTBSA	MBQ125G/MZHTBSA
MJQ125G	M125SPSA ⁷	MJQ125G/MSPSA ⁷
	M125SPTBSA ⁷	MJQ125G/MSPTBSA ⁷
	M125SF ⁷	MJQ125G/MSF ⁷
	M125ZHSA	MJQ125G/MZHSA
	M125ZHTBSA	MJQ125G/MZHTBSA
MNN125	M125SPSA ⁷	MNN125/MSPSA ⁷
	M125SPTBSA ⁷	MNN125/MSPTBSA ⁷
	M125SF ⁷	MNN125/MSF ⁷
	M125ZHSA	MNN125G/MZHSA
	M125ZHTBSA	MNN125G/MZHTBSA
MSQ125G	M125SPSA ⁷	MSQ125G/MSPSA ⁷
	M125SPTBSA ⁷	MSQ125G/MSPTBSA ⁷
	M125SF ⁷	MSQ125G/MSF ⁷
	M125ZHSA	MSQ125G/MZHSA
	M125ZHTBSA	MSQ125G/MZHTBSA

M Series wheels	Fork code	Castor code
QUQ125G	M125SPSA ⁷	QUQ125G/MSPSA ⁷
	M125SPTBSA ⁷	QUQ125G/MSPTBSA ⁷
	M125SF ⁷	QUQ125G/MSF ⁷
	M125ZHSA	QUQ125G/MZHSA
	M125ZHTBSA	QUQ125G/MZHTBSA
STQ125G	M125SPSA ⁷	STQ125G/MSPSA ⁷
	M125SPTBSA ⁷	STQ125G/MSPTBSA ⁷
	M125SF ⁷	STQ125G/MSF ⁷
	M125ZHSA	STQ125G/MZHSA
	M125ZHTBSA	STQ125G/MZHTBSA

Big M Series wheel	Fork code	Castor code
QTQ150G	M150ZPSA	QTQ150G/MZPSA ⁶
	M150ZPTBSA	QTQ150G/MZPTBSA ⁶
	M150ZF	QTQ150G/MZF ⁶
	M150ZHSA	QTQ150G/MZHSA
	M150ZHTBSA	QTQ150G/MZHTBSA

O Series wheels	Fork code	Castor code
HBS150	O150SPSA ⁸	HBS150/OSPSA ⁸
	O150SPTBSA ⁸	HBS150/OSPTBSA ⁸
	H150SF ⁸	HBS150/HSF ⁸
HBS200	O200SPSA ⁸	HBS200/OSPSA ⁸
	O200SPTBSA ⁸	HBS200/OSPTBSA ⁸
	H200SF ⁸	HBS200/HSF ⁸
HSR200	O200SPSA ⁸	HSR200/OSPSA ⁸
	O200SPTBSA ⁸	HSR200/OSPTBSA ⁸
	H200SF ⁸	HSR200/HSF ⁸
HUR150	O150SPSA ⁸	HUR150/OSPSA ⁸
	O150SPTBSA ⁸	HUR150/OSPTBSA ⁸
	H150SF ⁸	HUR150/HSF ⁸
HUR200	O200SPSA	HUR200/OSPSA ⁸
	O200SPTBSA	HUR200/OSPTBSA ⁸
	H200SF	HUR200/HSF ⁸

O Series wheels	Fork code	Castor code
OBQ125⁴	O125SPSA	OBQ125/OSPSA ⁸
	O125SPTBSA	OBQ125/OSPTBSA ⁸
	H125SF	OBQ125/HSF ⁸
OBQ150⁴	O150SPSA	OBQ150/OSPSA ⁸
	O150SPTBSA	OBQ150/OSPTBSA ⁸
	H150SF	OBQ150/HSF ⁸
OBQ200⁴	O200SPSA	OBQ200/OSPSA ⁸
	O200SPTBSA	OBQ200/OSPTBSA ⁸
	H200SF	OBQ200/HSF ⁸
ONR125	O125SPSA	ONR125/OSPSA ⁸
	O125SPTBSA	ONR125/OSPTBSA ⁸
	H125SF	ONR125/HSF ⁸
ONR150	O150SPSA	ONR150/OSPSA ⁸
	O150SPTBSA	ONR150/OSPTBSA ⁸
	H150SF	ONR150/HSF ⁸
ONR200	O200SPSA	ONR200/OSPSA ⁸
	O200SPTBSA	ONR200/OSPTBSA ⁸
	H200SF	ONR200/HSF ⁸

Supermarket trolley and travelator castors

NEW

Features

- Supplied in kits or individual components.
- UV stabilized to prevent fading and embrittlement outdoors.
- Non-standard colours available under minimal order quantity.
- Supermarket trolley components are made-to-order (non-stock items).
- Made in Australia.

Travelator trolleys must brake securely when traversing up and down steep travelators.

If only one brake leg is installed on travelator castors then trolleys may not brake securely, resulting in a runaway trolley that can cause injury or death. In busy commercial environments such as supermarkets and department stores, the risk of injury or death is even greater.

For this reason, Fallshaw mandate the use of two walk-way brake legs per travelator castor to achieve reliable, secure braking and safety.



Wheels



SPQ125GRBL²

Black and red high-strength PU on nylon, precision bearing, buffer cap



STQ125G

Grey rubber, round profile, precision bearing, thread guard



MSQ125G¹

Grey rubber, flat profile, precision bearing, thread guard

Forks



MZP

Swivel plate



MZH

Bolt hole swivel



MZF

Fixed plate



SZQ

Bolt hole swivel, precision bearing in head race



SZC

Bolt hole swivel

Accessories



SMBLRED²

Walk-way brake leg



SMBUFRED²

Castor buffer cap

Specifications

Wheel	Max load (kg)	Diameter x tread (mm)	Hub x bore (mm)
SPQ125GRBL	60	125 x 32	40 x 8
STQ125G	100	125 x 32	40 x 8
MSQ125G	150	125 x 34	40 x 8

Fork	Wheel size (mm)	Mount height (mm)	Turning radius (mm)
MZP	125	161	103
MZH	125	161	103
MZF	125	161	N/A
SZQ	125	161	103
SZC	125	161	103

Order codes

Wheel code	Fork code	Castor code
MSQ125G	M125ZP	MSQ125G/MZP
	M125ZH	MSQ125G/MZH
	M125ZF	MSQ125G/MZF
SPQ125GRBL	S125ZQ	SPQ125GRBL/SZQ*
	S125ZC	SPQ125GRBL/SZC*
STQ125G	M125ZP	STQ125G/MZP
	M125ZH	STQ125G/MZH
	M125ZF	STQ125G/MZF

¹ Wheel also available with plain bearing—MSA.

* For travelator castors, add SMBLRED x2 per castor for the walk-way brake leg.

² Also available in non-standard colours with a minimum order quantity of 500 pcs, including: Wheels—grey (SPQ125GGRY) or blue & white (SPQ125GBWH); Walk-way brake legs—grey (SMBLGRY) or blue (SMBLBLU); Castor buffer caps—grey (SMBUFGRY); or blue (SMBUFBLU).





Wheels

Soft wheels

- Grey rubber, blue rubber, black rubber and conductive.

Polyurethane wheels

Hard wheels

- Nylon and pallet truck wheels/rollers.

Pneumatics and puncture-proof

- Puncture-proof, steel centred and plastic centred wheels.

Soft wheels

Grey rubber

	Diameter x tread (mm)
 KSA	65 x 23
Grey rubber, flat profile, plain bearing	75 x 23
	100 x 23
 PSA/PSB	200 x 32
Grey rubber, non-marking, white polypropylene (PP) offset wheel, plain bearing (PSA) or deep groove ball bearing (PSB). Developed for floor polishers and scrubbers. PSA also available to suit 5/8" bore (58).	
 STQ	75 x 32
Grey rubber, round profile, precision bearing, thread guard	100 x 32
	125 x 32
 QTQ	150 x 34
Grey rubber, round profile, precision bearing, thread guard	175 x 34
 HSR	200 x 50
Grey rubber, roller bearing, thread guard available (HSR200G)	

Blue rubber

	Diameter x tread (mm)
 CBQ	75 x 33
Blue high-resilient elastomer, precision bearing, thread guard	100 x 33
	125 x 33
 MBQ	100 x 32
Blue high-resilient rubber, non-marking, long life, precision ball bearing, thread guard	125 x 32
 JBR	100 x 32
Blue high-resilient rubber, non-marking, long life, roller bearing	125 x 32
 HBR	150 x 28
Blue high-resilient rubber, non-marking, long life, roller bearing	200 x 28

Blue rubber

	Diameter x tread (mm)
 OBQ	100 x 50
Blue high-resilient rubber, non-marking, long life, precision ball bearing	125 x 50
	150 x 50
	200 x 50

Black rubber

	Diameter x tread (mm)
 PRB*	125 x 36
General purpose rubber utility wheel for lawn equipment and carts, deep groove ball bearing and offset centre	150 x 36
	200 x 36
 PRP250	250 x 50
General purpose rubber utility wheel, used on light lawn equipment and carts, plain bearing	
 U200/60C	200 x 60
Medium duty hand truck wheels, deep groove ball bearing, high-impact polypropylene centre, 20 mm bore (-POYB20) or 3/4" bore (-POYB34)	
 R250/50C¹	250 x 50
Puncture proof for wheelbarrows and utility equipment, precision ball bearing. Available in 20 mm bore (-PRYQ20), 3/4" bore (-PRYQ34) or (-PRYQ58)	
 R300/50C¹	300 x 50
Puncture proof for wheelbarrows and utility equipment, precision ball bearing. Available in 20 mm bore (-PRYQ20) or 3/4" bore (-PRYQ34)	
 R400/70C¹	400 x 70
Puncture proof for wheelbarrows and utility equipment, precision ball bearing. Available in 20 mm bore (-PRYQ20), 3/4" bore (-PRYQ34), or 1" bore (PRYQ25)	
 R250/75C²	250 x 75
Puncture proof for wheelbarrows and utility equipment, precision ball bearing. Available in 20 mm bore (-PRWQ20), 25 mm bore (-PRWQ25), 3/4" bore (-PRWQ34), or 5/8" bore (-PRWQ58)	

Black rubber

	Diameter x tread (mm)
 HRR200²	200 x 50
Black rubber wheel with roller bearing, for trolleys, carts and lawn mowers. Thread guard available (HRR200G)	
 RB200L	200 x 45
Solid black rubber wheel, with roller bearing, for wheelbarrows, utility equipment and waste bins	
 RPL200(DTR)	200 x 50
Offset recycled rubber wheel—the industry standard for wheelie bins commonly used in the waste industry. Includes a spring-loaded detent pin to easily install and secure the wheels.	
 R280/70R	280 x 70
Puncture proof solid cushioned wheel, with deep groove ball bearings in sizes 1" (-SRBB10), 20 mm (-SRBB20), 3/4" (-SRBB34) or 5/8" (-SRBB58). With precision ball bearings in sizes 20 mm (-SRQ20), 3/4" (-SRQ34) or 5/8" (-SRQ58)	
 R400X8-SQ10	400 x 95
Heavy duty wheel, designed for towing, precision ball bearing. Max tow speed—15 km/h	

Conductive wheels (See page 44)

Order codes

	Max load (kg)	Hub x bore (mm)	Bore—no bush (mm)
Grey rubber			
KSA65, KSA75, KSA100	50	30 X 12	8
PSA200	80	38 x 12.7	12.7
PSA200(58)	80	38 x 16	16
PSB200	80	38 x 12.7	12.7
STQ75G, STQ100G, STQ125G	100	40 x 8	8
QTQ150G, QTQ175G, QTQ200G	200	40 x 8	8
HSR200, HSR200G	250	60 x 12.7	20

	Max load (kg)	Hub x bore (mm)	Bore—no bush (mm)
Blue rubber			
CBQ75G	85	40 x 8	8
CBQ100G, CBQ125G	100	40 x 8	8
MBQ100G	140	40 x 8	8
MBQ125G	150	40 x 8	8
JBR100	150	45 x 10	20
JBR125	180	45 x 10	20
HBR150	230	60 x 12.7	20
HBR200	250	60 x 12.7	20
OBQ100	300	60 x 12.7	20
OBQ125	350	60 x 12.7	20
OBQ150, OBQ200	400	60 x 12.7	20
Black rubber			
PRB125	50	38 x 12.7	12.7
PRB150	75	38 x 12.7	12.7
PRB200	100	38 x 12.7	12.7
PRP250	100	45 x 16	16
U200/60C-POYB20	135	60 x 20	20
U200/60C-POYB34	135	60 x 19	19
R250/50C-PRYQ20	150	60 x 20	20
R300/50C-PRYQ20	150	60 x 20	20
R400/70C-PRYQ20	150	80 x 20	20
R250/75C-PRWQ20	180	75 x 20	20
HRR200, HRR200G	180	60 x 12.7	20
RB200L	200	53 x 25.4	25.4
RPL200(DTR)	100	100 x 20	20
R280/70R-SRBB10	200	60 x 25.4	25.4
R400X8-SQ10	600	80 x 25.4	25.4

* Also available with plain bearing—PRA

¹ 5/8" and 3/4" precision ball bearing or plain bush available.

² 20 mm, 5/8", 3/4" deep groove ball bearing, or 5/8", 3/4" plain bush available.

Polyurethane

		Diameter x tread (mm)
	KUQ* PU, precision bearing, optional thread guard	75 x 23 100 x 23
	QUQ¹ PU tyre on nylon, precision bearing, thread guard	75 x 32 100 x 32 125 x 32
	JUR* PU, roller bearing, optional thread guard	100 x 32 125 x 38
	HUR PU on nylon, roller bearing	100 x 40 125 x 40 150 x 40 200 x 48
	HUS* PU on nylon, stainless steel roller bearing, no thread guard	100 x 32 125 x 40 150 x 40 200 x 48
	WUQ PU, precision bearing, no thread guard	150 x 40 200 x 40
	XUQ PU on cast iron, precision bearing, no thread guard	102 x 50 127 x 50 152 x 50 203 x 50
	VUQ PU on cast iron, precision bearing, no thread guard	203 x 75 254 x 75
	AUQ PU on cast iron, precision bearing, no thread guard	200 x 102 250 x 102

* Also available with plain bearing—KUA, JUA, HUA

¹ Also available with plain bearing (QUA) and stainless steel bearing (QUC).

² 5/8" and 3/4" precision ball bearing or plain bush available.

Order codes

	Max load (kg)	Hub x bore (mm)	Bore—no bush (mm)
KUQ75, KUQ75G	100	30 x 8	8
KUQ100, KUQ100G	100	30 x 8	8
QUQ75G	200	40 x 8	8
QUQ100G	200	40 x 8	8
QUQ125G	200	40 x 8	8
JUR100, JUR100G	300	45 x 10	20
JUR125, JUR125G	300	45 x 10	20
HUR100	400	60 x 12.7	20
HUR125	400	60 x 12.7	20
HUR150	450	60 x 12.7	20
HUR200	500	60 x 12.7	20
HUS100	400	60 x 12.7	20
HUS125	400	60 x 12.7	20
HUS150	450	60 x 12.7	20
HUS200	500	60 x 12.7	20
WUQ150	600	60 x 12.7	20
WUQ200	600	60 x 12.7	20
XUQ100	600	62 x 12.7	20
XUQ125	800	62 x 12.7	20
XUQ150	1000	62 x 12.7	20
XUQ200	1000	62 x 12.7	20
VUQ200	2000	89 x 20	30
VUQ250	2000	89 x 20	30
AUQ200	3000	109 x 30	30
AUQ250	3500	109 x 30	30

Hard wheels

Nylon

	Diameter x tread (mm)
 LNN Hard nylon, plain bearing, no thread guard	50 x 20
 KNN Hard nylon, plain bearing, no thread guard	65 x 23 75 x 23 100 x 23
 DNQ Hard nylon, precision bearing, no thread guard	125 x 32
 DNQ...W White hard nylon, precision bearing, no thread guard	125 x 32
 MNN Hard nylon, plain bearing, no thread guard	75 x 32 100 x 32 125 x 32
 MNN...W White hard nylon, plain bearing, no thread guard	75 x 32 100 x 32 125 x 32
 JNR Hard nylon, roller bearing, optional thread guard	100 x 35 125 x 35
 ONA Hard nylon, plain bearing, no thread guard	100 x 40 125 x 40 150 x 40 200 x 40
 ONR Hard nylon, roller bearing, no thread guard	100 x 40 125 x 40 150 x 40 200 x 40
 WNQ Hard nylon, precision bearing, no thread guard	150 x 40 200 x 40

Pallet truck wheels

	Diameter x tread (mm)
 PLN Nylon, available in 20 mm (Q20), 25 mm (Q25) and 3/4" (Q34) precision bearings, or no bearing (NB)	200 x 48
 PLU Polyurethane, available in 20 mm (Q20), 25 mm (Q25) and 3/4" (Q34) precision bearings, or no bearing (NB)	200 x 48

Pallet truck rollers

	Diameter x tread (mm)
 PLN Nylon, available in 20 mm (Q20), 25 mm (Q25) and 3/4" (Q34) precision bearings, or no bearing (NB)	82 x 83 82 x 100

Order codes

Nylon	Max load (kg)	Hub x bore (mm)	Bore—no bush (mm)
LNN50	30	25 x 6	6
KNN65	50	30 x 8	12
KNN75	65	30 x 8	12
KNN100	70	30 x 8	12
MNN75, MNN75W	150	40 x 8	12
MNN100, MNN100W	150	40 x 8	12
MNN125, MNN125W	150	40 x 8	12
DNQ125, DNQ125W	200	40 x 8	8
JNR100, JNR125	300	45 x 10	20
ONA100	400	60 x 12.7	20
ONA125	400	60 x 12.7	20
ONA150	450	60 x 12.7	20
ONA200	500	60 x 12.7	20
ONR100	400	60 x 12.7	20
ONR125	400	60 x 12.7	20
ONR150	450	60 x 12.7	20
ONR200	500	60 x 12.7	20

Nylon	Max load (kg)	Hub x bore (mm)	Bore—no bush (mm)
WNQ150, WNQ200	600	60 x 12.7	20
Pallet truck wheels			
PLN200X48Q20	700	48 x 20	20
PLN200X48Q25	700	48 x 25	25
PLN200X48Q34	700	48 x 19	19
PLN200X48NB	700	48 x n/a	-
PLU200X48Q20	700	48 x 20	20
PLU200X48Q25	700	48 x 25	25
PLU200X48Q34	700	48 x 19	19
PLU200X48NB	700	48 x n/a	-
Pallet truck rollers			
PLN82X83Q20	800	83 x 20	20
PLN82X83Q25	800	83 x 25	25
PLN82X83Q34	800	83 x 19	19
PLN82X83NB	800	83 x n/a	-
PLN82X100Q20	800	100 x 20	20
PLN82X100Q25	800	100 x 25	25
PLN82X100Q34	800	100 x 19	19
PLN82X100NB	800	100 x n/a	-



Pneumatics and puncture-proof



Wheels

Puncture-proof wheels

Our premium Australian made polyurethane foam-filled tyres provide the greatest performance and reliability. The foam filling provides a light-weight bouncy performance, similar to air-filling, but without the risk of flat tyres.

These wheels boast 4 ply long life tyres, fitted to two piece wobble-free steel centres that are manufactured from thick 1.8 mm steel, unlike cheaper imports with 2 ply tyres and rims made from thin 0.6 mm steel.

Steel centred wheels

Designed for strength and performance, our wobble-free steel centred wheels boast 4 ply tyres, rims manufactured from 1.8 mm steel—with the 650 x 8 manufactured from 2 mm steel, and supplied with premium butyl rubber seamless (butt-joined) tubes.

Plastic centred wheels

Our plastic centred wheels are designed with thicker UV protected polypropylene sections in a multi-web design, making them stronger than most imported steel centres.

Combined with our standard 4 ply tyres and premium butt-joined tubes, these wheels offer excellent performance in wet and corrosive environments.

Maximum load capacities

Each wheel can carry the recommended load capacity at walking pace—8 km/h. If you are intending to tow your load, it is recommended that you do not use wheels with plastic centred rims, or exceed 15 km/h while carrying half the recommended load capacity.

Maximum inflation

Do NOT inflate over recommended tyre inflation pressure (30 psi).

Do NOT allow tyre pressure to drop below 20 psi or wheel may deflate and become very difficult to re-inflate. If you allow the tyre to go flat and you are unable to re-inflate it then you may need to buy an inner tube to be retro fitted to the wheel (see page 71 for spare parts).

Use of pneumatic wheels other than as recommended can be dangerous.

Nominal wheel size

Our code structure for pneumatics follows an internationally recognised convention that describes:

Tyre width (in inches) x rim diameter (in inches, measured from where the bead wire within the tyre sits on the rim).

So, for example a nominal wheel size of:

- 250x4 has a tyre width of approx 2.5 inches, on a 4 inch rim.
- 350x4 has a tyre width of approx 3.5 inches, on a 4 inch rim.
- 400x8 has a tyre width of approx 4.0 inches, on an 8 inch rim.

These sizes are nominal only. For more precise dimensions, refer to the diameter x tread width listed alongside other specifications.

Tread options

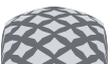
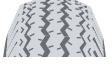
	RIB	Straight lines, grey non-marking rubber. Common for wheelchairs and light duty trolleys that need a softer ride.
	LUG	General purpose, outside use. Strongly marked cross lines on a fairly flat tread surface. Good for running in a straight line.
	LGG	Use LGG code for grey non-marking rubber where available.
	IND	The normal industrial type tread, a round profile with an even pattern.
	DMD	Chunky diamond or star shaped pads on a flatter surface. Often used in rougher construction sites. Good for softer grass surfaces but may become clogged with mud.
	STR	This knobby pattern is often preferred for outdoor use, good for gravel or uneven terrain.
	KNO	This knobby pattern is often preferred for outdoor use, good for gravel or uneven terrain.
	HWY	Designed to have a higher load rating for industrial work sites.
	GRA	A wide tread, designed specifically with ride-on mowers and associated equipment in mind. Will traverse virtually any surface they come across.

See page 71 for spare parts.

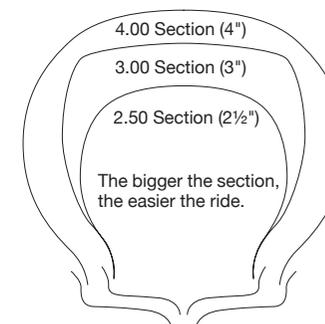



Puncture-proof wheels

Features

- Puncture-proof 4 ply long life tyres.
- Available in thick 1.8 mm thick steel rims.
- Fitted with heavy duty deep groove shielded bearings (SB) or precision bearings (SQ).

Puncture-proof tyres

Polyurethane foam-filled tyres are the premium 'pneumatic' (or puncture-proof) wheel option. The wheels are puncture-proof and provide the greatest performance and reliability. Puncture-proof tyres are fitted to two piece wobble-free steel centres. Manufactured from 1.8 mm steel*.

Bearings

'Deep Groove' shielded bearings¹ fitted to a toughened heavy duty housing enables true running and extra strength.

Tyres

4 ply for longer, rougher life (many imports use 2 ply).

For wheels pulled or pushed at low speeds (not driven) the tread pattern is not critical. The following are standard, other patterns can be offered by negotiation.

Order codes

Tread	Type	Diameter x tread (mm)	Hub x bore (mm)	Weight capacity at speed		Order code	Rim and bearing code	
				Max load (kg) at 8 km/h	Max load (kg) at 15 km/h			
 RIB (non-marking)	200 x 50	200 x 50	60 x 12.7	50	Not suitable	P200X50RIB	-SQ05	1/2"
 LUG	250 x 4	220 x 54	60 x 20	75	40	P250X4LUG	-SB20	20 mm
			60 x 19				-SB34	3/4"
			60 x 16				-SB58	5/8"
			60 x 15				-SQ15	15 mm
 IND	250 x 6	275 x 65	60 x 25.4	90	50	P250X6IND	-SB10	1"
			60 x 20				-SB20	20 mm
			60 x 19				-SB34	3/4"
			60 x 16				-SB58	5/8"
 STR	350 x 4	265 x 70	60 x 20	100	70	P350X4STR	-SB20	20 mm
			60 x 19				-SB34	3/4"
			60 x 16				-SB58	5/8"
			60 x 15				-SQ15	15 mm
 KNO	400 x 8	400 x 100	80 x 25.4	120	90	P400X8KNO	-SB10	1"
			84 x 20				-SB20	20 mm
			84 x 19				-SB34	3/4"
			84 x 16				-SB58	5/8"

* Some of the cheaper centres on the market are manufactured from steel as thin as 0.6 mm.

¹ Deep groove bearings can last up to three times longer than normal pressed bearings.



Pneumatics



Steel centred wheels

Features

- Strong 1.8 mm steel rims (2 mm rims for 650 x 8).
- 4 ply long life tyres (6 ply for HWY tread).
- Fitted with heavy duty deep groove shielded bearings (SB).

Steel centred pneumatics

Welded one piece strong wobble-free wheels. Centres up to and including the 500 x 6 are manufactured from 1.8 mm steel², and the 650 x 8 is of 2 mm thick steel².

Bearings

'Deep Groove' shielded bearings³ fitted to a toughened heavy duty housing gives true running and extra strength.

Tyres

4 ply (6 ply on HWY tread) for longer, rougher life (many imports use 2 ply).

For wheels pulled or pushed at low speeds (not driven) the tread pattern is not critical. The following are standard.

Tubes

Tubes are high quality butyl rubber seamless (butt-joined) for premium ride quality, high load capacity and long life.

Maximum Inflation

For information on maximum tyre inflation, please see page 63.

Order codes

Tread	Type	Diameter x tread (mm)	Hub x bore (mm)	Weight capacity at speed DO NOT EXCEED		Order code	Rim and bearing code	
				Max load (kg) at 8 km/h	Max load (kg) at 15 km/h			
 LUG	250 x 4	220 x 54	60 x 20	120	100	250X4LUG*	-SB20	20 mm
			60 x 19				-SB34	3/4"
			60 x 16				-SB58	5/8"
 DMD	300 x 4	250 x 70	60 x 20	140	110	300X4DMD*	-SB20	20 mm
			60 x 19				-SB34	3/4"
			60 x 16				-SB58	5/8"
 STR	350 x 4	265 x 70	60 x 20	180	160	350X4STR*	-SB20	20 mm
			60 x 19				-SB34	3/4"
			60 x 16				-SB58	5/8"
 IND	250 x 6	275 x 65	60 x 25.4	140	110	250X6IND¹	-SB10	1"
			60 x 20				-SB20	20 mm
			60 x 19				-SB34	3/4"
			60 x 16				-SB58	5/8"
 KNO	350 x 6	320 x 80	60 x 25.4	200	180	350X6KNO¹	-SB10	1"
			60 x 20				-SB20	20 mm
			60 x 19				-SB34	3/4"
			60 x 16				-SB58	5/8"
 HWY	400 x 8	400 x 100	84 x 25.4	360	340	400X8HWY¹	-SB10	1"
			84 x 20				-SB20	20 mm
			84 x 19				-SB34	3/4"
			84 x 16				-SB58	5/8"
 KNO	400 x 8	400 x 100	84 x 25.4	220	200	400X8KNO¹	-SB10	1"
			84 x 20				-SB20	20 mm
			84 x 19				-SB34	3/4"
			84 x 16				-SB58	5/8"
 GRA	500 x 6	330 x 125	84 x 25.4	220	200	500X6GRA¹	-SB10	1"
			84 x 20				-SB20	20 mm
			84 x 19				-SB34	3/4"
			84 x 16				-SB58	5/8"
 GRA	650 x 8	420 x 165	150 x 25.4	230	200	650X8GRA¹	-SB10	1"
			150 x 20				-SB20	20 mm
			150 x 19				-SB34	3/4"
			150 x 16				-SB58	5/8"

¹ Also available with precision bearings: 20 mm (-SQ20), 25 mm (-SQ25), 3/4" (-SQ34), 5/8" (-SQ58) and 1" (-SQ10).

² Many cheaper centres on the market are manufactured from steel as thin as 0.6 mm.

³ Deep groove bearings can last up to 3 times longer than normal pressed bearings.

* Also available with 15 mm precision bearings. Add -SQ15 to the end of code.



Plastic centred wheels

Features

- UV protected and corrosion resistant polypropylene rims.
- Available with heavy duty deep groove shielded bearings (B), or plain bearings (A). RIB tread available with roller bearings (PR) or precision bearings (PQ).
- Made in Australia.

Plastic centred pneumatics with butyl rubber seamless tubes

- Thick sections, large radii, multi-web design for strength (stronger than most imported steel centres).
- Corrosion resistant polypropylene with UV fade protection.
- High engineering standards for wobble-free wheels.
- High quality butyl rubber seamless (butt-joined) tubes.

Bearings

'Deep Groove' shielded bearings² fitted to a toughened heavy duty housing gives true running and extra strength.

Tyres

4 ply (6 ply on HWY tread) for longer, rougher life (many imports use 2 ply).

For wheels pulled or pushed at low speeds (not driven) the tread pattern is not critical. The following are standard, other patterns can be offered by negotiation.

Tubes

Tubes are high quality butyl rubber seamless (butt-joined) for premium ride quality, high load capacity and long life.

Order codes

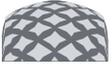
Tread	Style	Diameter x tread (mm)	Hub x bore (mm)	Weight capacity at speed DO NOT EXCEED		Order code	Rim and bearing code	
				Max load (kg) at 8 km/h	Max load (kg) at 15 km/h			
 RIB (non-marking)	200 x 50	200 x 50	60 x 20	75	Not suitable	200X50RIB	-PR20	20 mm
			60 x 12				-PQ12	12 mm
 LUG	250 x 4	220 x 54	60 x 20	100	Not suitable	250X4LUG*	-PWB20	20 mm
			60 x 19				-PWB34	3/4"
			60 x 16				-PWB58	5/8"
 LGG (non-marking)	250 x 4	220 x 54	60 x 20	100	Not suitable	250X4LGG*	-PWB20	20 mm
			60 x 19				-PWB34	3/4"
			60 x 16				-PWB58	5/8"
 IND	250 x 6	275 x 60	60 x 20	110	Not suitable	250X6IND*	-PWB20	20 mm
			60 x 19				-PWB34	3/4"
			60 x 16				-PWB58	5/8"
 DMD	300 x 4	250 x 70	60 x 20	120	Not suitable	300X4DMD*	-PWB20	20 mm
			60 x 19				-PWB34	3/4"
			60 x 16				-PWB58	5/8"
 STR	350 x 4	265 x 70	60 x 20	140	Not suitable	350X4STR*	-PWB20	20 mm
			60 x 19				-PWB34	3/4"
			60 x 16				-PWB58	5/8"
 KNO	350 x 6	320 x 80	60 x 20	140	Not suitable	350X6KNO*	-PWB20	20 mm
			60 x 19				-PWB34	3/4"
			60 x 16				-PWB58	5/8"
 KNO	400 x 8	400 x 100	105 x 25.4	200	Not suitable	400X8KNO¹	-PWB10	1"
			105 x 20				-PWB20	20 mm
			105 x 19				-PWB34	3/4"
			105 x 16				-PWB58	5/8"

Maximum Inflation

For information on maximum tyre inflation, please see page 63.

* Also available with plain bearings, indicated with an A, eg. 250X4LUG-PWA20.

¹ Also available with 1" plain bearing.

² Deep groove bearings can last up to three times longer than normal pressed bearings.



Fittings and spares

Fittings

- For 10 mm and 12 mm bolt hole castors.

Installing expanding adaptors

Spares

- For pneumatic and general wheels.

General spares

Fittings For 10 mm and 12 mm bolt hole castors

Grip-neck pintle adaptors

Shape	Material	Adaptor size (mm)	Suits tube (ID) internal diameter (mm)	Suits tube (OD) outside diameter (mm)	Suits wall thickness (mm)	Order code
Round	Nylon	11	10.9	12.7	0.9	S11
Round	Nylon	14	13.6	16.0	1.2	S14
Round	Nylon	17	16.6	19.0	1.2	S17
Square	Nylon	17	16.6	19.0 SQ	1.2	S17SQ
Round	Nylon	19	19.0	22.2	1.6	S19
Round	Nylon	23	23.0	25.4	1.2	S23
Square	Nylon	23	23.0	25.4 SQ	1.6	S23SQ



Long threaded tube ends (for use with castors)

Suits external tube size (mm)	Suits internal tube size (mm)	Internal thread diameter (mm)	Internal thread length (mm)	Knock-in length (mm)	Max load (kg)	Order code
Square tube ends with internal zinc plated mild steel thread (suits SPM10X60SETZ set screw—ordered separately)						
19	15–16	M10	24	22.5	50	AFLTS19/M10
40	36–37	M10	24	39	500	AFLTS40/M10
40	36–37	M12	24	39	500	AFLTS40/M12
51	47–48	M16	31	39	750	AFLTS51/M16



Square tube ends with internal nylon thread (suits SPM10X60SETZ set screw—ordered separately)

25	22–23	M10	24	39	250	AFLTPS25/M10
25	22–23	M12	24	39	250	AFLTPS25/M12
32	28–29	M10	24	39	350	AFLTPS32/M10
32	28–29	M12	24	39	350	AFLTPS32/M12
38	35–36	M10	24	41	500	AFLTPS38/M10
38	35–36	M12	24	41	500	AFLTPS38/M12
38	35–36	M16	31	42	500	AFLTPS38/M16
51	47–48	M10	24	39	750	AFLTPS51/M10
51	47–48	M12	24	39	750	AFLTPS51/M12



Round tube ends with mild steel thread (suits SPM10X60SETZ set screw—ordered separately)

25	22–23	M10	24	39	100	AFLTR25/M10
25	22–23	M12	24	39	100	AFLTR25/M12
32	28–29	M10	24	39	250	AFLTR32/M10
32	28–29	M12	24	39	250	AFLTR32/M12
38	35–36	M10	24	41	300	AFLTR38/M10
38	35–36	M12	24	41	300	AFLTR38/M12
51	47–48	M12	31	42	450	AFLTR51/M12



M10 Pintle bolts and M10 threaded tube ends

	Thread x length	Order code
	M10 x 30 mm	SPM10X30ZP
	M10 x 40 mm	SPM10X40ZP
	M10 x 50 mm	SPM10X50ZP
	3/8" x 19 mm	SP3/8X19ZP
	3/8" x 30 mm	SP3/8X30ZP
	3/8" x 40 mm	SP3/8X40ZP
3/8" x 50 mm	SP3/8X50ZP	
Set screw	M10 x 60 mm	SPM10X60SETZ
Description	Order code	
	M10 Nyloc nut.	SPM10NYLOCNUT

Grip-neck pintles (fits L, K & M series)

Description	Order code
 For L series, M10 grip-neck pintles are supplied loose to be retro-fitted. Pintle size: 8 mm OD x 39 mm long.	SP-GN
 For K & M series, M12 grip-neck pintles are supplied loose to be retro-fitted. Pintle size: 8 mm OD x 39 mm long.	SP-GNKM
 For K & M series, friction stem pintles are supplied loose to be retro-fitted to Rubbermaid carts. Pintle size: 11 mm OD x 36.5 mm long. Suits 12.7 mm bolt hole castors.	SP-GNKMRM
 Adaptor to suit Rubbermaid pintle SP-GNKMRM. Size: 15 mm OD x 42 mm.	SP-ADAPGNKMRM

3/8" fittings

Description	Order code
 Drill a 12.7 mm hole through the base and fit this down from the top, and screw the castor up into it through a washer. Internal thread 3/8".	38WTEE
 The base must be 3 mm thick, or washers of at least 25.4 mm OD used on both side to spread the load.	38WNUT
 Fits horizontal 1" x 1.6 square tube. Holds a 3/8" Whit nut in position 32 mm along a horizontal tube.	ENDPLUG25

For 12 mm bolt hole castors

Solid nylon pintles

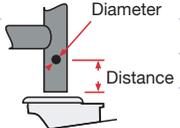
Description	Stem OD	Tube size (OD x wall)	Cross drill hole (distance from end x diameter)	Order code
 GENERAL CASTORS Includes 2 x inset nuts, 2 x washers, 2 x coach bolts, 1 x M12 x 60 bolt, 1 x M12 Nyloc nut	22 mm round	25 x 1.6 mm	 Diameter Distance	19 x 6 mm -AR22N
	28 mm round	32 x 1.6 mm		19 x 8 mm -AR28N
				19 x 6 mm -AFR22N
				19 x 8 mm -AFR28N

Solid steel pintles

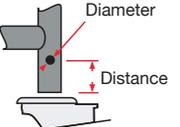
Stem OD	Length (mm)	Tube size (OD x wall)	Cross drill hole (distance from end x diameter)	Order code
19 mm round	48	22 x 1.2 mm	 Diameter Distance	19 x 8 mm -AR19Z
22 mm round	48	25 x 1.6 mm		19 x 8 mm -AR22Z
-AR19 with adaptor 22 mm square	48	25 x 1.6 mm SQ		19 x 8 mm -AS22Z
28 mm round	48	32 x 1.6 mm		19 x 8 mm -AR28Z

Square threaded tube ends (suits tubing >28 mm)

Order code (includes M12 x 75 mm set screw, zinc plated)	Order code (includes M12 x 75 mm set screw, stainless steel)	Order code (spare part excluding set screw)	Suits tube size (mm)
-TTESQ25Z	-TTESQ25S	SP-TTESQ25	25 x 25 square (1.6–2.5 wall)
-TTESQ32Z	-TTESQ32S	SP-TTESQ32	32 x 32 square (1.6–2.5 wall)
-TTESQ38Z	-TTESQ38S	SP-TTESQ38	38 x 38 square (1.6–2.5 wall)
-TTESQ50Z	-TTESQ50S	SP-TTESQ50	50 x 50 square (1.6–2.5 wall)

Order codes for set screws: SPM12X75SETZ (zinc plated), SPM12X75SETS (stainless steel).

Reducing bushes

Description	Order code
Convert 12 mm bolt hole to 10 mm	SPRB1/2-10
Convert 12 mm bolt hole to 8 mm	SPRB1/2-8

Pictured:
Round and square
expanding
adaptors.



Pintle set screws

Thread x length	Order code
M12 x 81 mm—standard	-ESETZ
M12 x 65 mm—stainless steel	-ESETSS
M12 x 35 mm	-E12x35SETZ
M12 x 40 mm	-E12x40SETZ
M12 x 45 mm	-E12x45SETZ
M12 x 50 mm	-E12x50SETZ
M12 x 55 mm	-E12x55SETZ
M12 x 65 mm	-E12x65SETZ
1/2" UNF x 1 1/8"	-E1/2x30SETZ
1/2" UNF x 1 9/16"	-E1/2x40SETZ
1/2" UNF x 2"	-E1/2x50SETZ
Set screw—stainless steel	M12 x 40 mm SPM12X40STSS
M16 x 40 mm (Adapts J, K and M series castors from 12 mm to 16 mm)	-PTLM16x40(12) <i>Order code includes pintle and nut</i>
Description	Order code
M12 Nyloc nut	SPM12NYLOCNUT
M12 Nyloc nut—stainless steel	SPM12NYLOCSS

Expanding adaptors (suits tubing <28 mm)

Shape	Material	Size (mm)	Tube size ID range	Mild steel bolt	Stainless steel bolt
Round	Nylon	19	18.5–21.0	-ER19	-ER19SS
Round	Nylon	22	21.5–24.0	-ER22	-ER22SS
Round	Nylon	28	25.0–28.0	-ER28	-ER28SS
Square	Nylon	19	18.5–21.0	-ES19	-ES19SS
Square	Nylon	22	21.5–24.0	-ES22	-ES22SS
Square	Nylon	28	25.0–28.0	-ES28	-ES28SS

Note: To order the pintle, and two-piece expanding adaptor (cone and expanding tube) as an unassembled spare part, use the code structure following the pattern in this example: SP-ER19.

If you just want the two piece expanding adaptor, without the pintle, as a spare part then add 'ADAP' to the code structure, for example: SP-ADAPER19.

If you want the pintle and expanding adaptor fitted to the castor, then drop the 'SP', for example: -ER19.

Installing expanding adaptors

Expanding adaptors are rated to a dynamic load rating of 300 kg per castor in applications up to 1.1 m/s (4 km/h) as per Standard AS1961.7-2004, ISO 22883:2004, subject to:

- Wheel diameter being no more than 150 mm.
- Tube thickness (of bed leg) being greater than or equal to 1.4 mm.
- Expanding adaptors being used with Fallshaw's pintle bolts—M12x80 (mild steel) or M12x65SS (stainless steel)—which have very specific geometry mechanical properties.
- Being installed as per the fitting instructions below: Torque of 25-30N/m resulting in bellowing (expansion) of between 1.0 – 1.5 mm.



Nylon expander

- Round or square.
- Available in 19, 22 and 28 mm.
- Available in white, grey or black.

Rubber expander

- Round or square.
- Available in 19, 22 and 28 mm.

Instructions

1. Remove the wheel.
2. Insert the bolt up through the castor bolt hole. A bolt with 13 mm across flats (A/F) hex is provided with castors.
3. Insert the cone into the tapered end of the sleeve, making sure fins on the cone lock into the downward opening slots.
4. Place the cone/sleeve on the bolt and screw down until the base of the sleeve just touches the centre bolt hole rivet on the castor.
5. You can replace the wheel now, or after the castor is attached to the trolley.



Note: Due to the greater offset, expanding adaptors are not recommended for use on 175 or 200 mm castors. If you do use expanding adaptors on these larger sizes be sure to fit a bolt 18 mm A/F hex (and branded M8.8).

6. If a weld bead is present inside the tube, align one of the slots in the adaptor sleeve with the bead. Try the fit of the cone/sleeve with the bead, it should be a neat sliding fit. If not screw the cone/sleeve down a little and try again. Repeat this process until it is a neat fit. (*Note: Sleeve pictured.*)
7. Insert the adaptor fully onto the tube, and then line up the notches of the expanding fitting with the slots on the castor rivet.

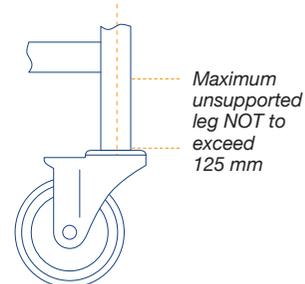
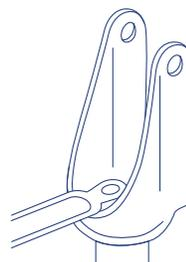

8. Put slight sideways pressure on the castor to help the fittings grip, then tighten the pintle up firmly to 'three finger tightness', ie the amount of torque you can get onto a standard spanner using your three middle fingers (25-30N/m). On round tubing some bellowing between 0.5 to 1.0 mm will occur, while on square tubing the bellowing is 1.0 to 1.5 mm, and can be used as an indication as to whether you have achieved the correct amount of torque.

Warning: Over tightening could split the tube (dangerous), and distort the fittings making them difficult to reuse. However, if you under tighten the fittings they will not grip the tube sufficiently and the castor may drop out (also dangerous).

Use the right amount of torque, 'three finger' tightness, and use the sign of bellowing as a guide.

If you haven't already done so, you can now assemble the wheel to the castor.

Maintenance

- You should retighten the adaptors after three months of use, then every 12 months after that. Remember the 'three finger' rule, ie. the amount of torque you can get onto a standard spanner using your three middle fingers (25-30N/m).
- To remove the castor, loosen the bolt, and then tap the head. This will drive the cone up out of the sleeve, and then the castor can be easily removed from the tube.
- A small amount of crushing of the cone is normal and proper (it prevents the bolt unscrewing unintentionally). The cone can be reused if not damaged. If damaged by excessive tightening the cone should be replaced. If the sleeve has been damaged, it also must be replaced.

Warped trolleys

You can compensate for a warped trolley by adding up to 8 mm in washers, or by using a similar piece of tubing to that of the trolley.

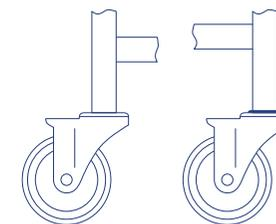

Order codes: Expanding adaptors

Shape	Adaptor colour	Size (mm)	Tube size ID range (mm)	Nylon adaptor code	Rubber adaptor code
Round	White	19	18.5–21.0	SP-ADAPER19	
Square	White	19	18.5–21.0	SP-ADAPES19	
Round	Grey	22	21.5–24.0	SP-ADAPER22	-ER22R
Square	Grey	22	21.5–24.0	SP-ADAPES22	-ES22R
Round	Black	28	25.0–30.0	SP-ADAPER28	
Square	Black	28	25.0–30.0	SP-ADAPES28	

Spares

For pneumatics and general wheels

Tubes—butyl rubber seamless



Description	Order code
Tube pneumatic 200 x 50	SPTUBE200X50
Tube pneumatic 250 x 4	SPTUBE250X4
Tube pneumatic 300 x 4 or 350 x 4	SPTUBE300/350X4
Tube pneumatic 250 x 6	SPTUBE250X6
Tube pneumatic 350 x 6	SPTUBE350X6
Tube pneumatic 500 x 6	SPTUBE500X6
Tube pneumatic 400 x 8	SPTUBE400X8
Tube pneumatic 650 x 8	SPTUBE650X8

Pneumatic tyres



Description	Order code
200 x 50 RIB tread	SPTYRE200X50RIB
250 x 4 LUG tread	SPTYRE250X4LUG
250 x 4 LGG tread	SPTYRE250X4LGG
250 x 6 IND tread	SPTYRE250X6IND
300 x 4 DMD tread	SPTYRE300X4DMD
350 x 4 STR tread	SPTYRE350X4STR
350 x 6 KNO tread	SPTYRE350X6KNO
400 x 8 KNO tread	SPTYRE400X8KNO
400 x 8 HWY tread	SPTYRE400X8HWY
500 x 6 GRA tread	SPTYRE500X6GRA
650 x 8 GRA tread	SPTYRE650X8GRA

Bearings



Description	Order code
B—Deep groove ball bearings:	
12.7 mm ID	SPBRGC05
25.4 mm ID	SPBRGC10
20 mm ID	SPBRGC20
19 mm ID	SPBRGC34
15.9 mm ID	SPBRGC58
Q—Precision ball bearings:	
#608 15.9 mm ID	SPBRGQ6004X58
#6205 2RS suits CFQ wheelchair, 8 mm ID	SPBRGQ6082RS
12 mm bore (suitable for pneumatics)	SPBRGQ6205X01
#6004 20 mm	SPBRGQ6004X20
#6004 19 mm ID	SPBRGQ6004X34
#6005 25 mm ID	SPBRGQ6005X25
With seals #6202 2RS, 15 mm ID	SPBRGQ6202X15
#6204 2RS, 20 mm ID	SPBRGQ6204X20
25.4 mm ID for 400 x 8 pneumatic	SPBRGQPNEU10

Plastic rims



Description	Order code
200 x 50: suits 200 x 50 with roller bearing	SPRIM200X50PRNB
200 x 50: suits 200 x 50 with precision bearing	SPRIM200X50PQNB
4 x 175: suits 250/300/350 x 4, no bearing	SPRIM4X175PW(NB)
6 x 200: suits 250/350 x 6, no bearing	SPRIM6X200PW(NB)
8 x 250: suits 400 x 8, no bearing	SPRIM8X250PW(NB)

Housing and reducing bushes



Description	Order code
Housing:	
Housing (nylon) for a #6004 Q ball bearing	SPHOUSING6004
Housing (nylon) flanged to suit a #6004 Q ball bearing	SPHOUSING6004FLG
Housing (nylon) flanged to suit a #6204 Q ball bearing	SPHOUSING6204
Reducing bushes:	
Flanged (grey nylon) 25.4 to 20 mm ID, 20 mm L—Grey	SPBSH10-20
Flanged (black nylon) 25.4 to 19 mm ID Flange, 20 mm L	SPBSH10-34
Flanged (black nylon) 25.4 to 15.9 mm ID Flange, 20 mm L	SPBSH10-58
Flanged (nylon) to suit 15.9 mm deep groove ball bearing (SPBRGC58), 15.9 to 12.7 mm	SPRB58-1/2
Plastic: 1 to suit 400x8 pneumatic wheels (8 x 250 rims)	SPBSH400X8PWP10
Plastic: 20mm to suit 400 x 8 pneumatic wheels (8 x 250 rims)	SPBSH400X8PWP20
Plastic: 3/4 inch to suit 400 x 8 pneumatic wheels (8 x 250 rims) x	SPBSH400X8PWP34
Plastic: 5/8 inch to suit 400 x 8 pneumatic wheels (8 x 250 rims)	SPBSH400X8PWP58

General spares

Axles, nuts and bolts



Description	Order code
Axle to suit VHD X Series (bolt & nut)	SPAXLEX
Axle to suit VHD V Series (bolt & nut)	SPAXLEV
Axle to suit CFQ wheelchair castors zinc plated bolt & nut	SPAXLECFQ
Axle to suit M Series, stainless steel (bolt & nut)	SPAXLEMSSBOLT
Axle to suit H Series (bolt & nut)	SPAXLEH
Axle to suit Y Series pneumatics (bolt & nut)	SPAXLEHPNEU
Axle to suit H Series, stainless steel (bolt & nut)	SPAXLEHSS
Axle to suit J Series (bolt & nut)	SPAXLEJ
Axle to suit K Series (bolt & nut)	SPAXLEK
Axle to suit M Series (bolt & nut)	SPAXLEM
Axle to suit M Series, mild steel (Chicago screw)	SPAXLEMCHICAGO
Axle to suit M Stainless Steel (Chicago screw)	SPAXLEMSSCHICAGO
Axle to suit O Series forks (bolt & nut)	SPAXLEO
M8X12 cup head bolt	SPBOLTM8CUPHEAD
M8X1.25 pitch conelock nut	SPNUTM8CONE
Axle to suit K Series (Chicago screw)	SPAXLEKCHICAGO

Spacers



Description	Order code
H Series spacer 61 mm L x 20 mm OD x 12.7 mm ID	SPSPACERH
H Series spacer 61 mm L x 20 mm OD x 16 mm D	SPSPACERH(16)
H Series spacer 61 mm L x 19 mm OD x 12.7 mm ID	SPSPACERH(19)
H & O Series spacer—stainless steel 61 mm L x 20 mm OD x 12.7 mm ID	SPSPACERROSS
H & O Series spacer—top hat (set of 2) 61 mm x 20 mm OD x 12.7 mm ID	SPSPACEROTOPHAT
Special J Series spacer 46 mm L x 20 mm OD x 12.7 mm ID	SPSPACERJ(05)R
J Series spacer to suit plain bearings 46 mm L x 12.7 mm OD x 10 mm ID	SPSPACERJA
J Series spacer to suit roller bearing 46 mm L x 20 mm OD x 10 mm ID	SPSPACERJR
J Series spacer—stainless steel 46 mm L x 12.7 mm OD x 10 mm ID	SPSPACERJSS
K Series spacer 31 mm L x 12 mm OD x 8 mm ID	SPSPACERK
M Series spacer 41 mm L x 12 mm OD x 8 mm ID	SPSPACERM
M Series spacer—stainless steel 41 mm L x 12 mm OD x 8 mm ID	SPSPACERMSS

Allen key set

Description	Order code
5 mm Allen key set to suit Chicago screw axles used in K and M Series	SPALLENKEY5

Bearings and bushes



Description	Order code
R—Roller bearing for H Series, 20 mm ID, stainless steel	SPBRGH20SS
B—Deep groove 12.7 mm for PRB (also suits GPBO)	SPBRGPRB05
Q—Precision bearing for M Series 608	SPBRGMQ608ZZ
Q—Precision bearing for M Series 608, stainless steel	SPBRGMQ608ZZSS
Q—Precision bearing for K series 608, twin seal	SPBRGKQ608NG
R—Roller bearing for J series, 20 mm ID	SPBRGJC20
R—Roller bearing for H Series, 20 mm ID	SPBRGR20
R—Roller bearing for J Series, 20 mm ID, stainless steel	SPBRGR20JSS
Sleeve for H Series roller bearing	SPBRGR20SLEEVE
R—Roller bearing, 19 mm bore for H, R and N Series	SPBRGR34

Grease nipples



Description	Order code
Grease nipples (to add to a wheel)	SPGNIPPLEW
Grease nipples (to add to a fork)	SPGNIPPLEF



Thread guards (set of 2)



Description	Order code
Thread guard set—KSP75	SPTGDKSP75Z
Thread guard set—KJA75	TGDKJ75GRY
Thread guard set—KUQ100	SPTGDKUQ100SET
Thread guard set—MSQ	SPTGDMSQSET
Thread guard set—MNN75	SPTGDMNN75SET
Thread guard set—MNN100	SPTGDMNN100SET
Thread guard set—JUR100	SPTGDJUR100
Thread guard set—JUR125	SPTGDJU125SET
Thread guard set—JBA100/125	SPTGDJB100
Thread guard set—HB & HS 200	SPTGDHB200SET
Thread guard set—HU 200	SPTGDHU200SET
Thread guard set—PR Wheels	SPTGDGHUBCAP

Plates



Description	Order code
H & O ISO top plate raw	SPPLATEHISORAW
H & O NA top plate raw	SPPLATEHNARAW
Flat spacer plate 96 mm x 78 mm	SPPLATEMISO
Flat spacer plate 96 mm x 78 mm—stainless steel	SPPLATEMISOSS

Buffers—D section (hollow)



Description	Order code
Normally placed around the edges of the trolley (between corner buffers) to prevent damage to door jambs. These are fitted by pushing a (off-cut) metal strip along the centre of the section and screwing through into the side of the trolley. The head of the screw will pop through the outer rubber leaving a small hole. If the strip is to be fitted on a rounded corner, this should be of at least 50 mm radius to prevent buckling of the strip.	D25SPOOL Length per spool: 80 m
	D25BAG Length per bag: 8 m
	D25CUT Length: 1 m

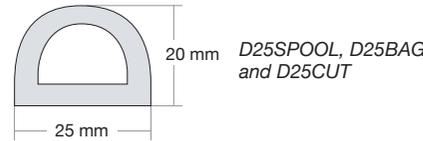

Buffers—corner



Description	Order code
Corner buffers can be fitted to new or existing trolleys with square corners, reducing damage to walls and door jambs. They are fitted by four pan head self tappers (not supplied), which are recessed down inside each arm of the buffer (No. 10 x 1" or similar). Being made from TPE they are very resistant to abrasion and chemicals. The end profile is matched to the 'D' section rubber strip.	CB8025

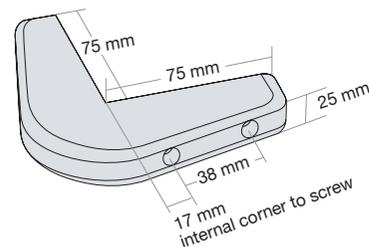

Buffers—leg



Description	Order code
ROUND TPE These are used to prevent damage to corridor walls. The buffers are placed onto tubular legs just before the castors. When a trolley approaches a wall the buffers make contact first and freely revolves on the tubing, thus rolling the trolley along the wall so it causes no damage. In the case of 25.4 mm square tubing the urethane buffers are supplied with a 32 mm hole, together with a 'dress-cap' with a 25.4 mm square inner and a 32 mm round outer.	BJ100X25 Suit 25.4 mm round tubing OD
	BJ100X32 Suit 32 mm round tubing OD
	BJ100X25SQ Suit 25.4 mm square tubing OD
	BJ125X25 Suit 25.4 mm round tubing OD
	BJ125X32 Suit 32 mm round tubing OD
	BJ125X25SQ Suit 25.4 mm square tubing OD
	BJDC25 Black dress cap to suit 25.4 mm square tubing OD

Buffers—caps



Description	Order code
Buffer caps are suitable for bolt hole castors used in wet areas.	-BUF22: Suit -ER19 or -AR19
	-BUF25: Suit -ER22 or -AR22
	-BUF28: Suit -ER28 or -AR28
They are designed to lock out water and prevent corrosion by protecting the castor's twin ball race and its stainless steel balls.	-BUF32: Suit 33 mm OD of hollow stem
Available in five sizes.	-BUF33.5: Suit 34 mm OD of hollow stem



TugAXIS2T
ELECTRODRIVE.COM.AU

COOLER BAG
PROMOTION
6 Pk x 2

PRODUCED IN AUSTRALIA
PRODUCED BY ORLANDO WINE
MUNLAND PLANT
SOUTH AUSTRALIA 5102

W087912

Electrodrive

Powered mobility equipment

Designing and manufacturing powered materials handling equipment since 1987, our range of pedestrian operated powered tugs and movers have been proven to be the safest way to work with heavy trolleys, carts and equipment within and around your facility. We all know that pushing or pulling a heavy load increases the risk of back and shoulder injuries. Using a tug or mover reduces the risk by doing all the heavy work for you. And unlike driving a forklift, the risk of collision with other people or objects is eliminated because the operator has a clear view of what's ahead.

Unlike the competition, our range of tugs and movers are ergonomically designed, allowing your body to move forward with the load in a natural walking position. With intelligently designed tiller handles and controller grips on our tugs and movers, paired with powerful motors that can tow up to 10 tonnes, you're always in control, and you can use them all day long without risk of strain on your back or shoulders.

So whether you're working with planes, trains, automobiles or hospital beds, we will have a powered solution for you.

Choosing the right tug or mover

1 Determine the weight and incline of the load being moved

The nominal towing capacity of our tugs relates to the weight that can be pulled on a flat surface (with a friction coefficient of 0.5 such as dry concrete or bitumen).

The practical rule of thumb to determine which tug is right for your application is to get the pull force (in kilograms) required to start your load moving (on the worst case surface of your application) and divide it by 0.04. This will give you the pulling power required.

$$\frac{\text{Pull force (kg)}}{0.04} = \text{Pulling power (kg)}$$

So, for example, if it takes 30 kg of pull force to get your trolley moving on your intended surface, divide this by 0.04 to identify the pulling power required of 750 kg, meaning that you will need a tug that can pull more than the Tug Compact (500 kg), and would need the power of a Tug Axis 1T, which will exceed your pull force comfortably.

Another way of thinking about this is that for every 1T of load to be pulled, the force to pull it will increase by 40 kg.

Measuring the pull force required to start the load moving can be done with a weight scale—of the type used to weigh produce at the green grocers, or the more modern digital luggage scales such as those shown in the photos above.

It is important to measure the pull force required on the worst case of your application. Perhaps a linen cart will need to follow a route that includes the flat internal hospital passageways on carpet, as well as an outside bitumen area with a 6 degree slope. Make sure you measure the worst case scenario—in this example, the outside inclined area when wet (to simulate the added slipperiness that occurs when raining).

A final 'top tip'

Measuring the incline can be done with a smart phone app. Go to your app store and search for 'measure incline' or 'measure slope' or 'spirit level' and you'll have many options to choose from for both Apple and Android smart phones.

Angle of slope	Typical applications
0–2°	Flat surface.
2–8°	Mild slope (eg. typical driveway).
8–11°	Moderate slope (eg. basement ramp or loading dock ramp).
11–14°	Severe slope (eg. car park ramps under high rise buildings).



Angle of slope (degrees)

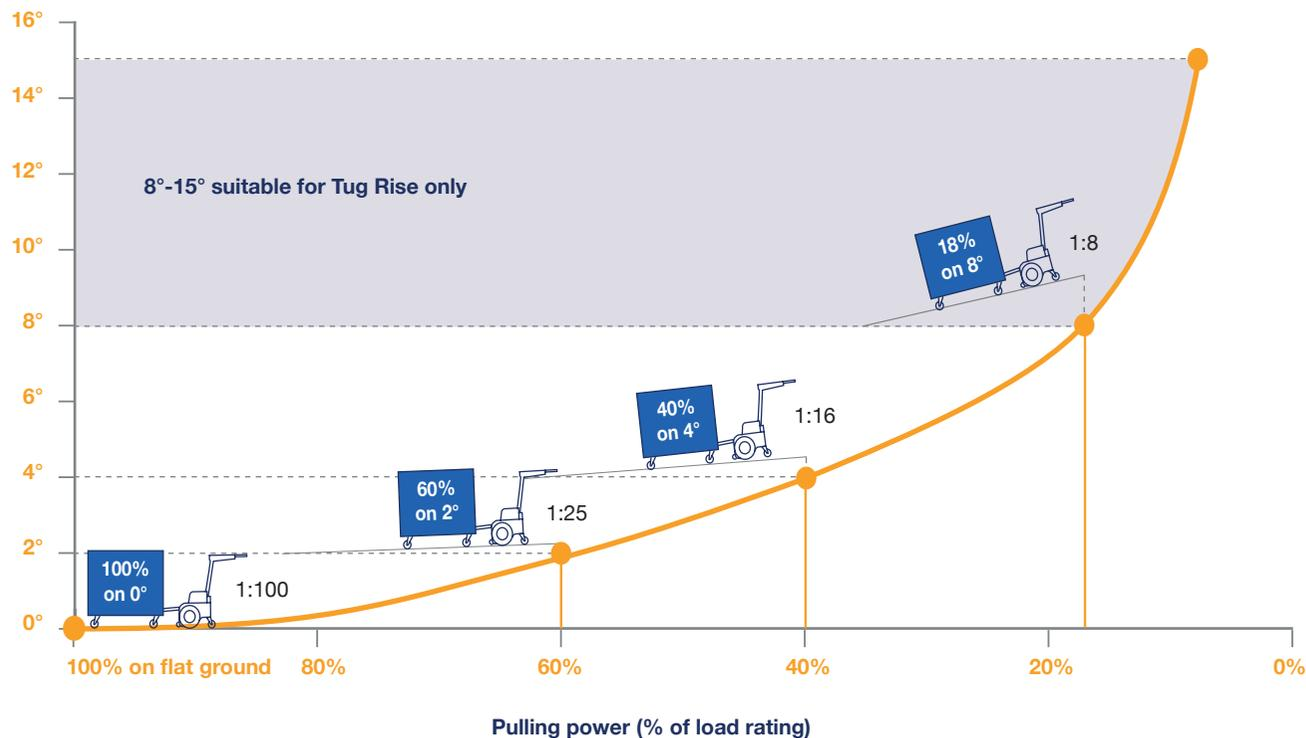

2 Determine whether it will be used in confined or open spaces

Please use the following guide to help determine the suitability for your application.

Please note: A 'confined space' refers to a small space with a single doorway (standard width of 820 mm).

Suitable for confined spaces		
	Tug Compact	Nimble and tiny. Smallest footprint and turning circle. Passes through a single doorway with ease. Excellent for moving stock trolleys inside and outside.
	Tug Axis 1T and 2T	Tug Axis 1T and 2T models can fit through small office doorways with ease if the item being towed can follow it. Always lock the turret when not towing loads.
	Tug Axis 4T and 5T	Tug Axis 4T will fit through a single doorway on slow speed and with its turret locked to allow it to be parked at the end of the day, but the Tug Axis 5T is slightly wider.
	Gzunda bed movers	Excellent for indoor applications, lifts and most confined spaces. The machine does not drive laterally so it needs about 2x2m to pivot in a circle when not attached to a hospital bed.
	Gzunda Linen Mover	Excellent for indoor applications and most confined spaces. Its tiller arm can be folded to reduce length by a further 500 mm so it can be manoeuvred around corridors and parked easily.
	Transpak powered trolley	Ideal for moving meal delivery systems or multiple boxes through corridors. Fits through single doorways in slow speed for easy charging or storage.
Suitable for open spaces		
	Tug Rise 1T	Large, high-traction forklift wheels make the Tug Rise a bit wider than the others (as it is designed for steep carpark ramps) so it won't fit through standard doorways.
	Tug Tough 10T	Perfect for moving loads weighing between 4-10 tonnes in open spaces. Can go through a single doorway for storage or charging.

3 Determine if the load will have existing hitch points

Tug hitches to suit the most popular trolleys

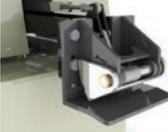
Pin hitch Auto-latching hitch

Hitches that adapt to different trolley designs





Clamp hitch Flex hitch Groove hitch

Hitches for bed movers





Flex hitch Gripper hitch Ratchet hitch
Available in a range of sizes.

Hitches for bins



Double wheelie bin hitch 660 and 1100 litre bin hitches

Hitches for trailers, caravans and boats



Tow ball A-frame hitch Hydraulic arm lift hitch

4 Determine the load's wheel configuration

Castor configuration will affect towing

Four swivel castors will not trail properly behind the towing unit—they will cut corners rather than follow the unit. They will also tend to whip—over correct any sideways displacement and sway from side-to-side as they travel.

These problems become more acute if more trolleys are linked in a train. We offer fixed wheel skate hitch (pictured) accessories to correct this problem for situations where it's not feasible to replace two of the four swivel castors on an existing trolley fleet.



If two fixed castors are used at the rear of the trolley it eliminates the whip, and improves trailing and towing.

An ideal configuration is to mount two swivel castors 1/6 of the length of the trolley from the front of the trolley and two fixed castors 1/3 of the length of the trolley from the rear. This gives little whip, and good trailing. Note though, that such trolleys should not have a heavy load concentrated at the rear end or they will tip backwards.

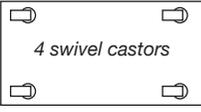
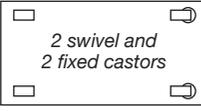
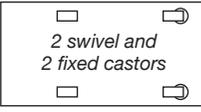
DIRECTION OF TRAVEL →	Trailing	Whip	Stability
 4 swivel castors	Poor	Bad	Very good
 2 swivel and 2 fixed castors	Good	Least	Very good
 2 swivel and 2 fixed castors	Good	Little	Good

→ 1/3 ← → 1/6 ←

Take a closer look.
Scan the QR code.



Tugs

Features across the range

- Powerful battery operated motor.
- Tiller control handle for 'front of load' operation.
- Foldable tiller handle.
- Three speed control with forward and reverse.
- Emergency stop and back-off safety buttons.
- Customisable with a wide variety of hitches available.
- Smart battery charger (supplied standard with AU/NZ plugs – add 'EU', 'US' or 'UK' to the end of tug order codes for European, US or United Kingdom plugs).
- Lead free.
- Low maintenance.
- Made in Australia.

Take a closer look.
Scan the QR code.

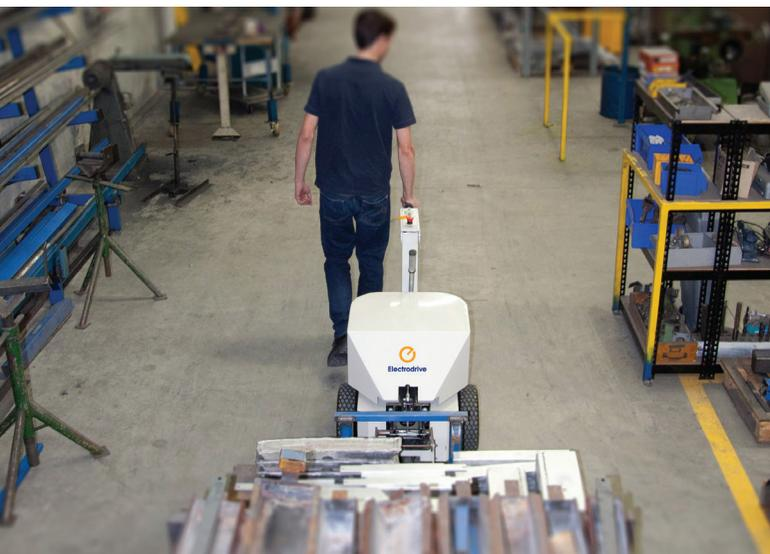

Tug Compact

- Tow up to 500 kg on flat ground with reduced towing capacity up to 8 degrees.
- Compact and easy to manoeuvre in tight corridors.
- Non-marking tyres suitable for indoor use.

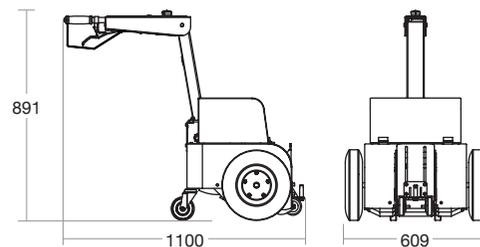

Order code

Tug Compact 500 kg (no hitch)	TUGCOM500NH
Pin hitch (16 mm)	EDHT1810-002
Pin hitch (19 mm)	EDHT1810-043
Clamp hitch (general duty)	EDHTCLAMP001*

* The Tug Compact has a permanently fixed turret, so when using our EDHTCLAMP001 Clamp hitch you will also need to add EDHT1810-006 (Self-centering hitch) to allow the trolley to follow behind it. Optional: EDHT1810-035 (Skate hitch).



Tug Rise 1T

- Designed to tow on slopes/ramps.
- Towing capacity of up to 1 tonne on a 15 degree slope.
- Turret with turret lock for easy reversing.
- Suitable for towing bins from basement car parks.
- Heavy duty high-traction wheels.

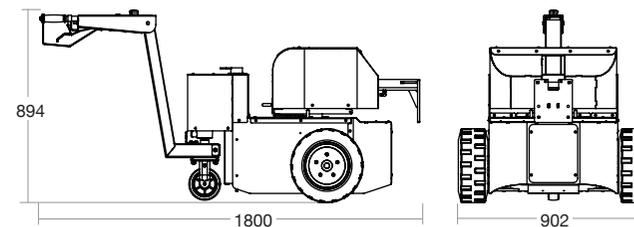

Order code

Tug Rise 1 tonne (no hitch)	TUGRISE1TNH
Pin hitch (19 mm)	EDHT1316
Pin hitch (29 mm)—standard for 660/1100L bins	EDHT1810-052
Auto-latching hitch	EDHT1810-024

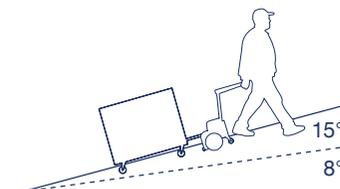



NEW

Tug Axis 1T/2T

- Available in 1 and 2 tonne models for towing on flat ground, with reduced towing capacity up to 8 degrees.
- Turret with turret lock for easy reversing.
- Suitable for retail and light industrial towing.

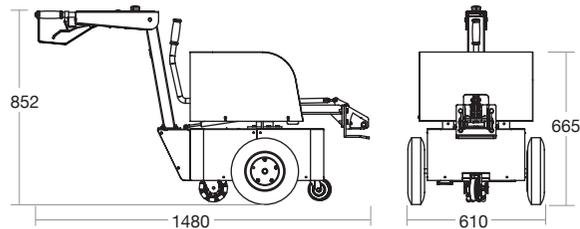

Order code

Tug Axis 1 tonne (no hitch)	TUGAXIS1TNH
Tug Axis 2 tonne (no hitch)	TUGAXIS2TNH
Auto-latching hitch	EDHT1810-024
Pin hitch (16 mm)	EDHT1313
Pin hitch (19 mm)	EDHT1316
Clamp hitch (heavy duty)	EDHTCLAMP002*
Groove hitch	EDHTGROOVE001
Tow ball A-frame hitch	EDHT1810-023

* EDHTCLAMP002 – 1000 kg maximum capacity.



NEW

Tug Axis 4T/5T

- Available in 4 and 5 tonne models for towing on flat ground, with reduced towing capacity up to 8 degrees.
- Turret with turret lock for easy reversing.
- Suitable for large retail and heavy industrial towing.

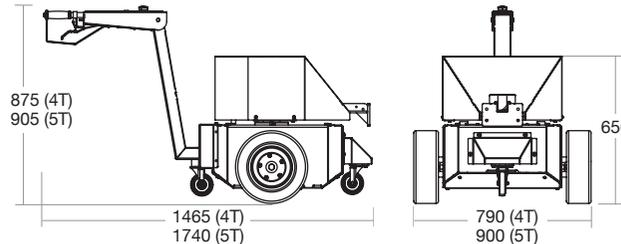

Order code

Tug Axis 4 tonne (no hitch)	TUGAXIS4TNH
Tug Axis 5 tonne (no hitch)	TUGAXIS5TNH
Auto-latching hitch	EDHT1810-024
Pin hitch (19 mm)	EDHT1316
Pin hitch (29 mm) – standard for 660/1100L bins	EDHT1810-052
Tow ball A-frame hitch	EDHT1810-023
Hydraulic arm lift kit	EDHYDARMLIFTKIT

* Adds 480 mm of length to the tug when using hydraulic arm lift kit (EDHYDARMLIFTKIT).



Tug Tough 10T Heavy duty

- Tow up to 10 tonnes on flat ground, with reduced towing capacity up to 8 degrees.
- Heavy duty construction, perfect for pulling very heavy equipment, vehicles and aircraft.
- Fully contained unit—wheels and drive system housed within box covers.
- Hazard yellow for high-visibility and industrial work areas.
- Flashing amber warning light (optional).

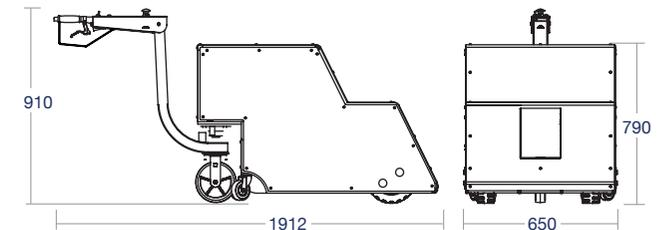

Order code

Tug Tough 10 tonne (no hitch)	TUGTOUGH10TNH
Pin hitch (32 mm)	EDHT10TPIN
Pin hitch (50 mm)	EDHT10TPIN50
Hook hitch	EDHT10THOOK
Tow ball hitch	EDHT1352

Linen movers

Features across the range

- Designed for towing linen trolleys up to 500 kg.
- Powerful battery operated motor.
- Tiller control handle for 'front of load' operation.
- Three speed control with forward and reverse.
- Emergency stop and back-off safety buttons.
- Smart battery charger (supplied standard with AU/NZ plugs – add 'EU', 'US' or 'UK' to the end of tug order codes for European, US or United Kingdom plugs).
- Low maintenance.
- Made in Australia.

Take a closer look.
Scan the QR code.



Tug Compact Linen Mover

- Tow up to 500 kg.
- Compact and easy to manoeuvre in tight corridors.
- Supplied with clamp hitch.
- Ideal for towing linen trolleys fitted with two swivel and two fixed castors.

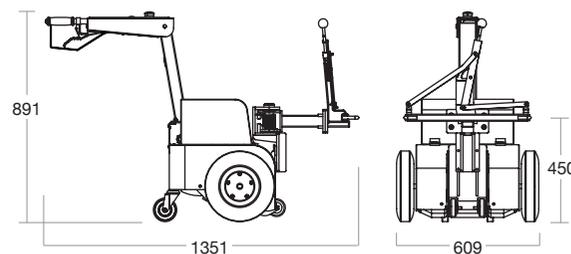

Order code

Tug Compact linen mover 500 kg
(with clamp hitch, range 520–720 mm)

TUGLINEMOVER



GZ30 Linen Mover

- Tow up to 500 kg.
- Compact and easy to manoeuvre in tight corridors.
- Middle tine design—ideal for towing linen trolleys fitted with four swivel castors.
- Supplied with clamp hitch (see page 90 for hitch options).

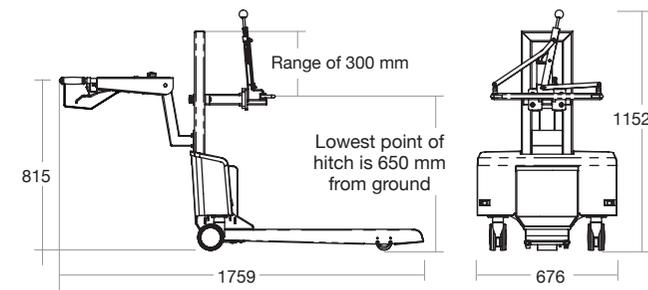

Order code

Gzunda Linen Mover 500 kg
(with clamp hitch, range 520–720 mm)

GZLINEMOVER

Gzunda Linen Mover (no hitch)

GZLINEMOVER(NH)



Meal delivery

Features across the range

- Designed for carrying or towing meal delivery systems up to 500 kg.
- Powerful battery operated motor.
- Tiller control handle for 'front of load' operation.
- Three speed control with forward and reverse.
- Emergency stop and back-off safety buttons.
- Smart battery charger (supplied standard with AU/NZ plugs — add 'EU', 'US' or 'UK' to the end of tug order codes for European, US or United Kingdom plugs).
- Low maintenance.
- Made in Australia.

Take a closer look.
Scan the QR code.



Why not consider installing a powered drive wheel to your equipment? See P5W (non-retractable) on page 84.



Pictured carrying a Burlodge meal delivery pod (not included).

Transpak powered trolley

- Carries up to 500 kg.
- Suitable for carrying meal delivery systems including those from Burlodge, Socamel and Versigen.
- Frame size can be built to suit your requirements.

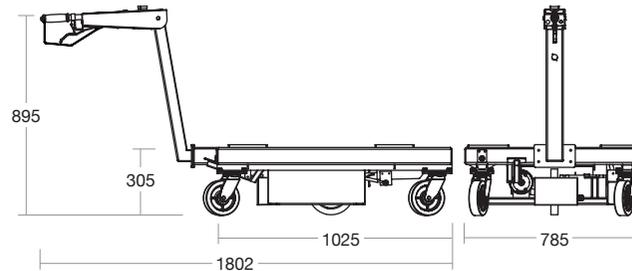

Order code

Transpak powered trolley 500 kg

TRANSPAK500



Tug Compact

- Tow up to 500 kg.
- Customised hitch to suit all pod and mobile meal delivery systems*.
- Compact and easy to manoeuvre in tight corridors.

Order code

Tug Compact 500 kg (no hitch)

TUGCOM500NH

* Clamp hitch shown is for illustration purposes only. See range of hitches on page 90.

Tug hitching options



Pin hitch

EDHT1810-002 or EDHT1313 (16 mm diameter)
 EDHT1810-043 or EDHT1316 (19 mm diameter)
 EDHT1810-052 (29 mm diameter) standard for 660/1100L bins
 EDHT10TPIN (32 mm diameter)
 EDHT10TPIN50 (50 mm diameter)

Typically used on trolleys with tow bars such as meal trolleys and stock trolleys, the pin hitch can also be mounted upside-down to suit spring-loaded drawbars that push upwards. These are becoming more common in workplaces, as no bending is required.

Suitability

For use on Compact Tug (16mm and 19mm); Tug Rise 1T (19mm only); Tug Axis 1T and 2T (16mm and 19mm); Tug Axis 4T and 5T (19mm only) and Tug Tough 10T (32mm and 50mm).

When fitted to the Tug Compact and Tug Tough, the pin hitch enables vertical and horizontal movement.

Note: When fitted to the Tug Axis, the turret must be locked to disable pivoting, otherwise uncontrolled movement will occur.

Applications

Meal trolleys for hospitals, roll cages for supermarkets.

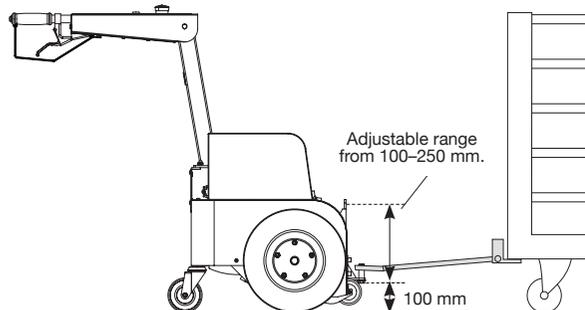

Auto-latching hitch

EDHT1810-024

To use the auto-latching hitch, a trolley with a 25 mm diameter tow bar is needed. Electrodrive can provide a tug hitch bar (EDHT1010) which can be welded or bolted to your trolley if required (pictured).

The auto-latching hitch enables limited vertical movement. Horizontal movement is provided by the Tug Axis's rotating turret. The hitch is set at 320 mm from the ground.

Suitability

For use on Tug Rise 1T and Tug Axis range (1T, 2T, 4T and 5T models).

Applications

Industrial, heavier-duty trolleys with loads of 1-2 tonne.

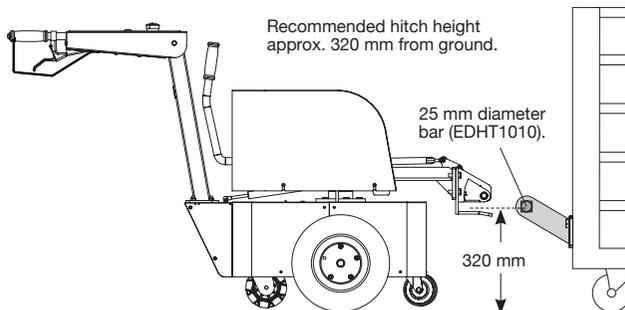

Tow ball A-frame hitch

**ALL NEW
DESIGN**

EDHT1810-023

The tow ball hitch is most commonly used for the movement of trailers, caravans or boats.

The tow ball position can be adjusted manually to suit a height of 500 or 600 mm from ground.

Suitability

For use on Tug Axis range (1T, 2T, 4T and 5T models).

Applications

Single-axle trailers or caravans fitted with a standard 50 mm tow ball coupling and a jockey wheel to safely lower the load over the tow ball.

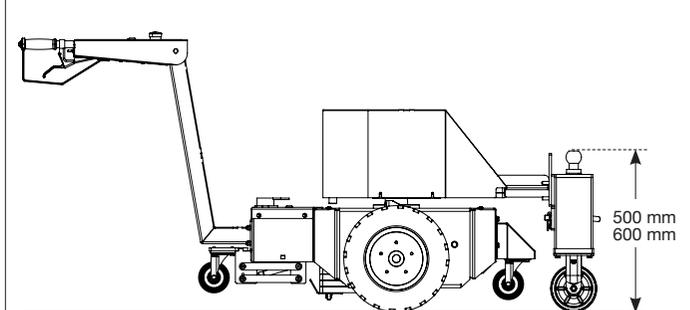



Hydraulic arm lift kit

ALL NEW DESIGN

EDHYDARMLIFTKIT

This hitch is used for moving trailers, caravans or boats which have a 50 mm tow ball coupling.

The hitch arm is operated by hydraulic system running at high pressure, via a self-centering toggle switch situated near the handle. The pinch points surrounding the arm movement and must be avoided at all times during the operation of the hydraulic system.

Suitability

For use on Tug Axis 4T and 5T models.

Applications

Single-axle trailers or caravans fitted with a standard 50 mm tow ball coupling and a jockey wheel to safely lower the load over the tow ball.

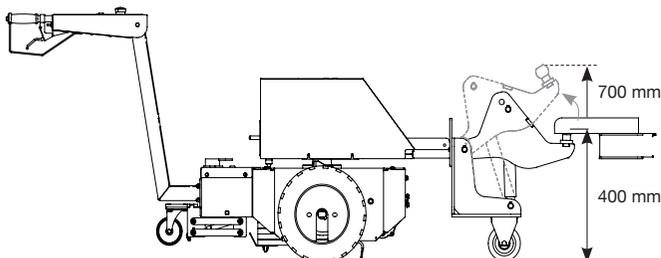

Clamp hitch

EDHTCLAMP001 (general duty)
EDHTCLAMP002 (heavy duty)

Clamp hitches grab the trolley frame from the outside, by clamping the load between two hooks. These hitches are commonly seen on linen trolleys belonging to linen companies, hospitals and hotels. The clamp hitch has a range of 520–720 mm so it suits trolleys with a width between these two numbers.

EDHTCLAMP001 hitch must be supplied with EDHT1810-006 (self-centering hitch) for the Tug Compact or EDHT1810-035 (optional skate hitch). EDHTCLAMP002 does not require self-centering.

Suitability

The General Duty Clamp Hitch (EDHTCLAMP001) is suitable for use on Tug Compact. The Heavy Duty Clamp Hitch (EDHTCLAMP002) is suitable for use on the Tug Axis 1/2T.

Clamp hitches are ideal for trolleys that do not have an existing hitch point to connect to.

Applications

Linen trolleys, roll cages and trolleys with wire mesh sides.

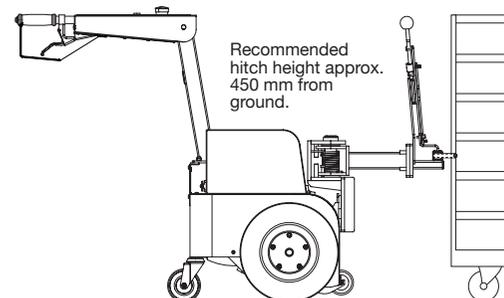

Groove hitch

ALL NEW DESIGN

EDHTGROOVE0484

Groove hitches are designed for plastic tub trolleys with slotted handles or metal linen trolleys.

EDHTGROOVE0484 hitch is our new swivel mechanism which locks the tubs from inside the handle grooves.

These hitches are normally used on plastic linen trolleys which don't have an exposed or open frame to grab onto from the outside.

Suitability

For use on Tug Axis 1T and 2T models.

Applications

Rotomoulded linen trolleys with slotted handles.

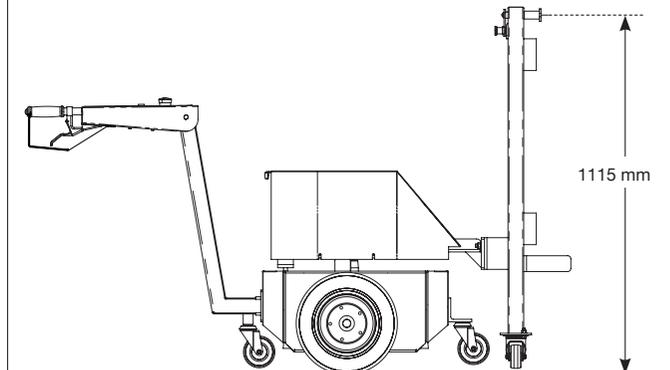



Double wheelie bin hitch

EDTWINBINHITCH

Move up to two wheelie bins at the same time using this hitch.

To hitch or unhitch the bins, simply lift the handle. The height of the hitching point can be manually adjusted with two wing knobs located on the side of the vertical frame.

Suitability

For use on Tug Compact and the Tug Axis range.

Applications

Moving moulded wheelie bins ranging from 80 to 240 litres with adjustable height and width.

**ALL NEW
DESIGN**



660 & 1100 litre bin hitches

EDUNIBH6611F (Front hitching bracket)
EDUNIBH6611R (Rear hitching bracket)

Our universal hitching brackets fit underneath 660 litre or 1100 litre bins (between the castor plates and bin) to maximise strength and enable towing of multiple bins at once.

The hitching brackets are suitable for ramps up to 14 degrees. The tow pins are secured by R-pins.

Note: Must be used with 29 mm pin hitch (EDHT1810-052).

Suitability

For use on Tug Rise and the Tug Axis range.

Applications

For towing one or more 660 and 1100 litre bins.

Accessories

Directional lock tabs for steering (order code LMDLSULO) for trolleys with 4 swivel castors—retrofitted on 2 x rear-mounted swivel castors to stop bins swaying side-to-side.

**ALL NEW
DESIGN**



Warning: Never tow with four swivel castors. Towing bins with four swivel castors will cause problems with trailing and 'fishtailing'—cutting corners, rather than following the unit.

For safety purposes, directional lock tabs are fitted to your bin's existing rear swivel castors to enable controlled steering and towing in a straight line.

Take a closer look.
Scan the QR code.

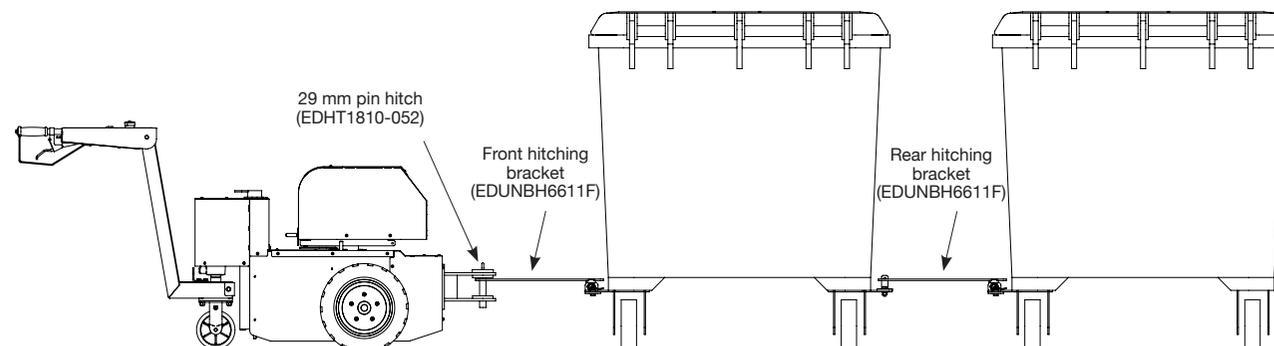
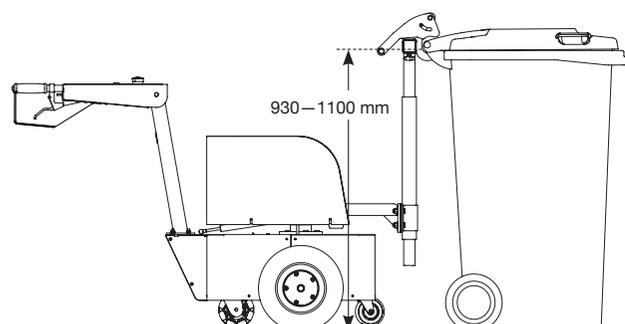



Tub trolley mover

Designed for the food and retail industries, Electrodrive's ergonomic tub trolley improves manual handling of food and goods by reducing the risk of musculoskeletal injury caused by awkward bending and pushing of heavy tubs at floor level.

Customer trials have proven to increase the overall productivity by 30%. This was achieved by eliminating manual handling associated with lifting, shifting and tipping heavy tubs, and reducing the labour hours involved in the daily process of emptying food waste.

Features

- Available in powder-coat for general use, or stainless steel (grade 304) for raw food handling.
- Fitted with quality Australian-made Fallshaw food-grade castors—100 mm non-marking grey rubber: Two swivel (MSC100G/MSP) and two fixed (MSC100G/MSF).
- 560 kg standard load rating (with supplied Fallshaw castors).
- Foot pedal for lifting and securely locking tubs into the trolley frame, or for releasing them.
- Can be used with an Electrodrive tipper (contact us for info).

Benefits

- Can be designed to suit your current tubs.
- Proven to increase efficiency by up to 30%.
- Ergonomic design to reduce the risk of injury.
- Easy to use—simply position the trolley on either side of the tub, and then push down on the foot pedal to lift the tub and securely lock it into place—for effortless transportation of tubs.
- Depending on your application, it is available in powder-coated for general use or stainless steel for raw food handling.
- Highly manoeuvrable and easy to use.
- Made in Australia.

Typical applications

Suitable for the food and retail industries for improved handling of food and goods.

ALL NEW DESIGN

Take a closer look.
Scan the QR code.

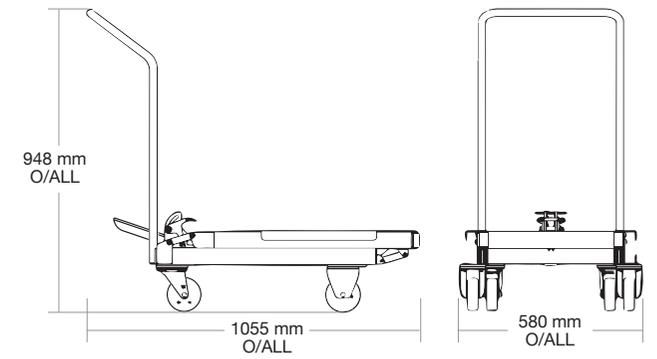

	Order code
Tub trolley	SIE3038
Tub and trolley tipper	SIE3029

Powered fifth wheel

The Powered Fifth Wheel (P5W) is a retrofittable solution for converting your manually pushed trolleys or hospital beds into powered ones.

Controlled with an ergonomically designed control grip for a natural walking posture, the Powered Fifth Wheel works with your trolley or bed's other four wheels to help you move heavy loads safely and efficiently.

Features across the range

- Tow up to 400 kg on flat ground.
- Three-speed control with forward and reverse.
- Emergency stop and back-off safety buttons.
- Customisable with a wide variety of hitches available.
- Smart battery charger.
- Made in Australia.

Take a closer look.
Scan the QR code.



P5W (non-retractable)

Simple control

Retrofittable kit

- Tow up to 400 kg on flat ground.
- Simple control unit (mounted vertically or horizontally – adaptable to suit 20-52 mm tube).
- Non-retractable fifth wheel in carriage.
- Batteries: 2 x 33Ah gel, assembled within slide-out carriage.
- Charger.

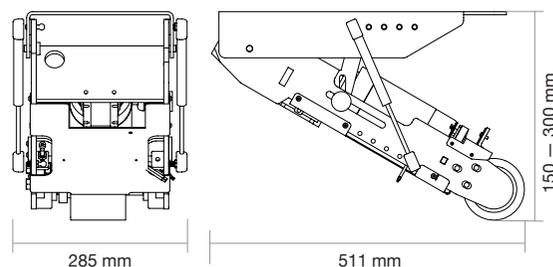

Control unit (vertical)

Control unit (horizontal)



Slide out battery carriage

Non-retractable fifth wheel

Order code

Retrofittable kit

Non-retractable Powered Fifth Wheel with simple control:

Vertically mounted	P5W400VBAU
Horizontally mounted	P5W400HBAU

Items available separately

Control unit (vertical)	EDP5WCONTROLV
Control unit (horizontal)	EDP5WCONTROLH
Non-retractable fifth wheel in carriage	EDP5WWHEEL
Slide out battery carriage	EDP5WBATCARRIAGE
Batteries: 2 x 33Ah gel batteries	EDBAT12V33AHGEL
Charger: 7Ah, AU plug	EDCHARGER7AhAU ¹

¹ International chargers are also available. Replace 'AU' at the end of the order code with 'US', 'EU' or 'UK'. For example EDCHARGER7AhUS.

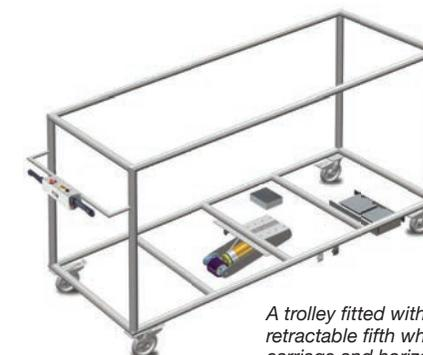

A trolley fitted with the non-retractable fifth wheel, battery carriage and horizontal control unit.



P5W (retractable)

Two-hand control

Retrofittable kit

- Tow up to 400 kg on flat ground.
- 'Gzunda' style two-hand control unit.
- Retractable fifth wheel in carriage.
- Batteries: 2 x 33Ah gel.
- Charger.
- Ideal for hospital beds.

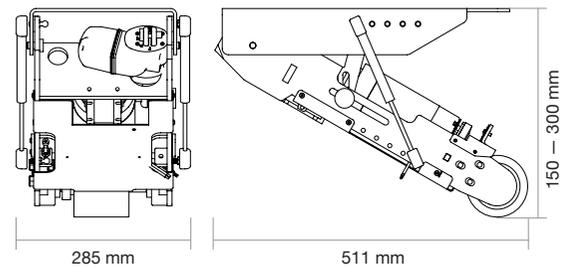

Order code

Retrofittable kit

Retractable powered fifth wheel with 'Gzunda' style two-hand control

GZP5W400HBAU

Items available separately

Control unit	EDGZP5WCONTROL
Retractable fifth wheel in carriage	EDGZP5WWHEEL
Batteries: 2 x 33Ah gel batteries	EDBAT12V33AHGEL
Slide out battery carriage	EDP5WBATCARRIAGE
Charger: 7Ah, AU plug	EDCHARGER7AhAU ¹

¹ International chargers are also available. Replace 'AU' at the end of the order code with 'US', 'EU' or 'UK'. For example EDCHARGER7AhUS.



Control unit



Slide out battery carriage



Retractable fifth wheel



A hospital bed fitted with the retractable fifth wheel and control unit.

Please note

Traction and load rating of the fifth wheel is to suit a maximum load of 400 kg on flat ground. Towing capability will reduce substantially as the angle of the slope increases. If less downwards force is required to suit lighter trolleys (less than 60 kg) we can customize the unit.

Sold with Australian (AU) charging plug and charger. Also sold with plugs to suit USA (US), Europe (EU) and the United Kingdom (UK). Change last two digits of product code accordingly.

Both models require a minimum of 150 mm ground clearance. Fitting to the bed or trolley is quoted separately. We have a wide range of brackets and fittings.

Water resistance IP rating of IP55.

Patient movers

Battery powered patient movers for enabling a single user to move hospital beds or stretchers.

Features across the range

- Powerful battery operated motors move up to 800 kg.
- Highly manoeuvrable in tight spaces.
- Three speed operation with forward, reverse and emergency stop.
- Intuitive controls with twist grip throttle and horn.
- Customisable with a wide variety of hitches available.
- Smart battery charger (supplied standard with AU/NZ plugs – add 'EU', 'US' or 'UK' to the end of Gzunda order codes for European, US or United Kingdom plugs).
- Made in Australia.

Take a closer look.
Scan the QR code.



Gzunda GZ10SL

- Move up to 500 kg.
- Middle tine* for easy manoeuvrability in tight spaces.
- Three speed operation with forward, reverse and emergency stop.
- Variety of hitches available (see page 90 for hitch options).



Gzunda GZS

- Move up to 600 kg.
- Split tine design with no under-bed clearance required.
- Three speed operation with forward, reverse and emergency stop.
- Variety of hitches available (see page 90 for hitch options).



Pictured: Gzunda GZ10SL

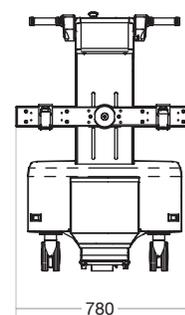
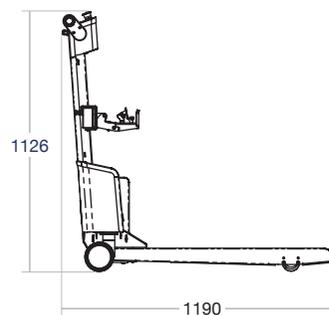

Order code

Gzunda GZ10SL 500 kg (no hitch)

GZ10SL(NH)¹

¹ Requires 90 mm of clearance under the bed.

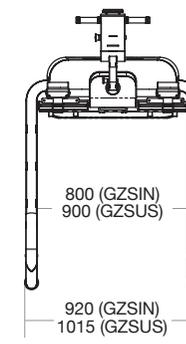
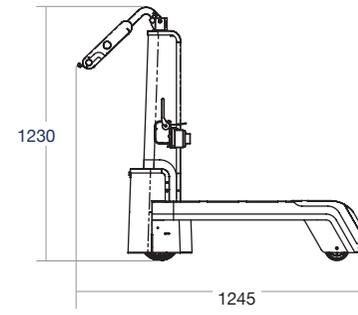

Order code

Gzunda GZS 600 kg split tine (International) (no hitch)

GZSIN(NH)

Gzunda GZS 600 kg split tine (US) (no hitch)

GZSUS(NH)



NEW

Gzunda GZBARI

- Move up to 800 kg.
- Automatic park brake to anchor beds and trolleys when staff let go.
- Power steering with dual-drive hub motors.
- Long lasting deep-cycle gel cell batteries.
- Middle tine* for easy manoeuvrability in tight spaces.
- Variety of hitches available (see page 90 for hitch options).



Pictured: The Gzunda GZS

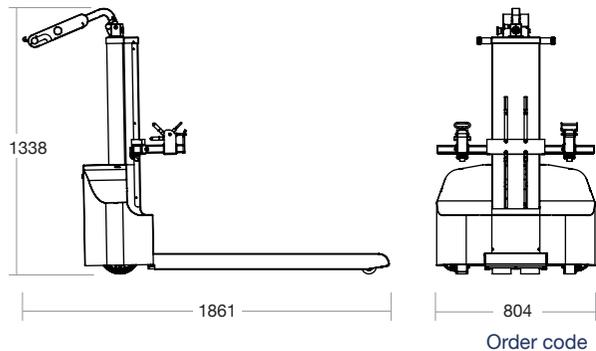

Gzunda GZBARI 800 kg (no hitch)

GZBARI(NH)

* Requires 100mm of clearance under the bed (can be modified to 90mm if required).

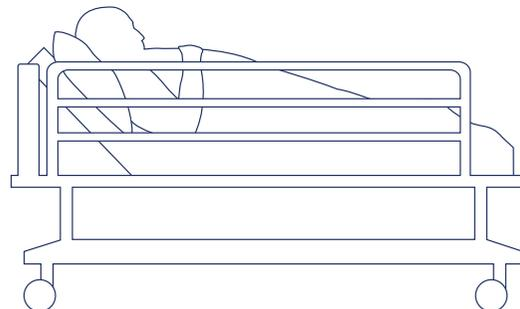

The GZBARI is specially designed for moving bariatric patients with ease.

Please note:

¹ NH: Bed movers are sold without a hitch. Hitches are sold separately to suit the range of bed models in your fleet. Please visit Electrodrive.com.au and navigate to the Patient Movers page where you can download our Bed Compatibility Chart or contact us to check which model is most suitable for your beds, trolleys, chairs and stretchers.

Gzunda hitching options

Common hitches to suit Gzunda bed movers and linen movers.

							
Hitch	Flex hitch kit with hitch bar.	Ratchet hitch kit with hitch bar.	Manual gripper hitch kit with hitch bar.	Manual gripper hitch kit with hitch bar.	Automatic gripper hitch kit with hitch bar.	Groove hitch kit.	Clamp hitch kit.
Suitability	Gzunda patient movers (excluding bariatric).	Gzunda patient movers (excluding bariatric).	Gzunda bariatric patient mover.	Gzunda patient movers (excluding bariatric).	Gzunda patient movers (suits 20-40 mm bed frame) (excluding bariatric).	Gzunda linen mover and Tug linen mover.	Tug Compact linen mover.
Applications	Hospital beds, stretchers, treatment chairs and low-lying trolleys/gurneys.	Hospital beds, stretchers, treatment chairs and low-lying trolleys/gurneys.	Hospital beds, stretchers, treatment chairs and low-lying trolleys/gurneys.	Hospital beds, stretchers, treatment chairs and low-lying trolleys/gurneys.	Hospital beds, stretchers, treatment chairs and low-lying trolleys/gurneys. It has manual adjustment to suit any bed frame.	Moulded plastic laundry trolleys with a width of 700-720 mm. It has manual height adjustment to suit any handle height/handle slots.	Metal framed trolleys, caged linen trolleys, surgical instrument Rapini trolleys and tall stock trolleys.
Size	780 mm length	780 mm length	780 mm length	780 mm length	780 mm length	650 mm (overall length of bar) Hitch range: 295-650 mm (horizontal) and 95 mm (vertical).	520-720 mm length
Order code	EDHTFLEX001	EDHTRATCH001	EDHTMANGRIP001	EDHTMANGRIP002	EDHTAUTOGRIP001	EDHTGROOVE001*	EDHTCLAMP001

Retrofittable hitch kits to suit the common hitch bars above

(to enable multiple hitch styles on your bed mover or linen mover)

							
Hitch unit kit	Flex	Ratchet	Manual gripper	Manual gripper	Automatic gripper	60 mm hitch extension suits GZ10SL and GZS	120 mm hitch extension suits GZ10SL and GZS
Order code	EDHTFLEX001-001	EDHTRATCH001-001	EDHTMANGRIPPER-001	EDHTMANGRIP-002	EDHTGRIPP001-001	EDHTHITCHEXT60	EDHTHITCHEXT120

* EDHTGROOVE001: The whole hitch bar can be manually raised up and down to suit different handle slots. The 95 mm vertical hitch range relates to the range of movement inside the hitch point to allow it to securely hold on to the trolley.

Hitch extensions

Take a closer look.
Scan the QR code.



Bariatric wheelchair mover



**ALL NEW
DESIGN**

Features and benefits

- Moves up to 350 kg on a 6 degree gradient.
- Maximum speed of up to 5 km per hour.
- Compact and easy to manoeuvre in tight spaces.
- Easy to steer with an excellent turning circle.
- Quiet operation and smooth ride for patient comfort.
- Automatic park brake.
- Battery operated and rechargeable.
- Non-marking tyre.
- Key on/off switch.
- Ergonomic design.
- Park brake release—to enable manual operation in the event of a flat battery.
- Two 12V 33Ah batteries with a 24V smart charger.
- Made in Australia.

Hitching

- Simple push-button hitching/unhitching.

Safety features

- Emergency stop button and 'back-off' bar.
- Horn for attracting attention.
- Automatically decelerates and stops when not driving forward.
- Fits a variety of wheelchairs, commodes and treatment chairs.

The Bariatric Wheelchair Mover is an excellent addition to any aged care, hospital or rehabilitation centre looking to remove the risk of injury and fatigue from manually pushing, pulling and steering heavy chairs.

With the added benefit of enhancing patient comfort by replacing those sudden jerky vibrations and movements with a smooth and assisted drive.

Typical applications

Ideal for moving heavy wheelchairs, commodes and treatment chairs around hospitals (patient transportation) as well as airports (passenger transportation).

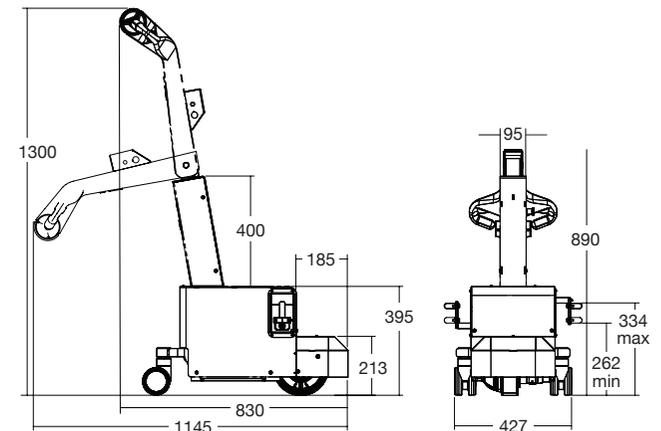

How much effort does it take to push a 100 kg patient?

The required sustained force:

- Manually pushing a patient in a wheelchair = 8 kg
- Using the wheelchair mover = < 1 kg

Force required on a slope for manual-pushing is higher.

For more info on acceptable frequencies of sustained pushing of wheeled equipment over stated distances, refer to the Snook & Ciriello table, page 141.

Order code

Bariatric wheelchair mover

WHLCHAIRMOVEBARI

Take a closer look.
Scan the QR code.



Trolley collection

Front-of-house trolley collection system

Stock trolleys are notoriously bulky and cumbersome. They block supermarket aisles and cause disruptions for shoppers and staff.

Due to their size and fixed castor configuration they can become very heavy to steer manually, which not only slows down the overall job of stocking shelves, but present a risk of injury to staff and shoppers.

Electrodrive Trolley Collection System (ETCS)

The ETCS is an Electrodrive powered tug with a 'remote' switch to enable the operator to steer the tug using a remote control.

With enhanced safety features the remote control tug assists when transporting trolleys in high traffic and pedestrian areas.

Benefits

- Reduce time stocking shelves.
- Improve safety for staff and shoppers.
- Move multiple trolleys at a time.
- Maximise forward visibility while steering from the front of the trolley queue.
- Always have two points of contact with trolleys (with the operator at the front, and the tug at the back).
- Unhitch trolleys from the rear of the trolley queue, making it easier to park in trolley bays.
- Safely manoeuvre through busy areas with increased visibility from the amber strobe light on pole.

Take a closer look.
Scan the QR code.

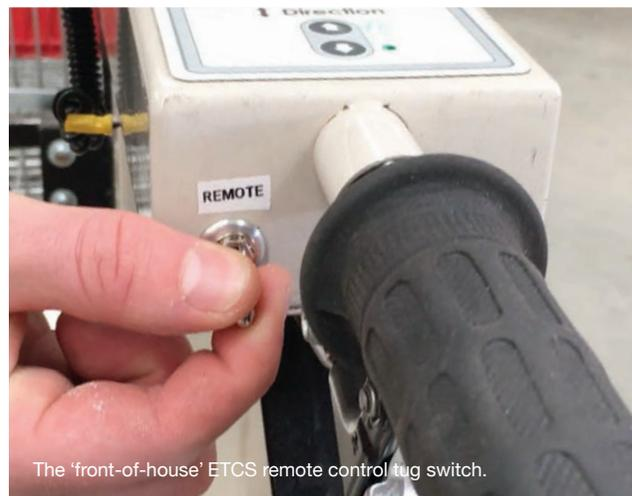

The 'front-of-house' ETCS remote control tug switch.



The 'front-of-house' ETCS remote control.

Wheelset mover

NEW

Moving train bogie wheelsets

- Suitable for moving rail wheelsets, train bogies, cylinders, pipes, spools, industrial drums.
- Powerful battery operated motors move up to 1400 kg.
- Highly manoeuvrable.
- Three speed operation with forward, reverse and emergency stop.
- Intuitive controls with tiller control handle, horn and warning light.
- Smart battery charger (supplied standard with AU/NZ plugs – add 'EU', 'US' or 'UK' to the end of Gzunda order codes for European, US or United Kingdom plugs).
- Made in Australia.

Take a closer look.
Scan the QR code.

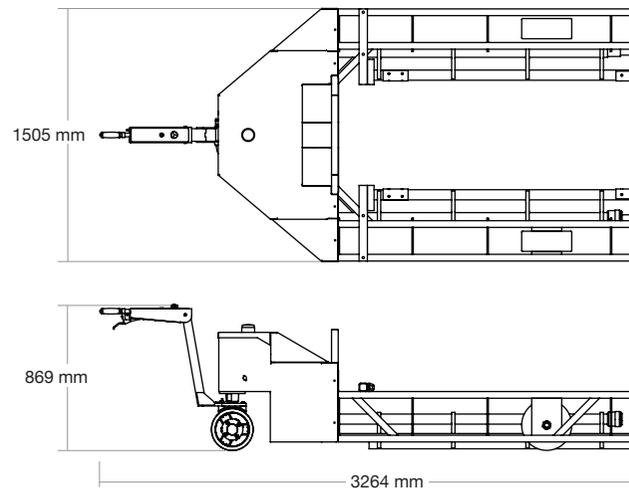

Load capacity	Move up to 1400 kg on flat surface.
Max. speed	Up to 4.1 km per hour (fully programmable).
Speed mode	Three speed control with forward, reverse and emergency stop.
Battery	Two 12V 73Ah MK-cyclic gel / suspended electrolyte batteries (deep cycle, long-lasting, maintenance-free) with 24V smart charger.
Dimensions (L/W/H)	3264/1505/869 mm 2704/1505/869 mm (will tiller arm raised)
Order code	WHEELSETMOVER



LIFTMASTER

✓ YES
✗ NO

13

UNIVERSAL
BIN LIFTER
UBL250HY1800

14-7-15

ALLSHAW GROUP LTD
14-7-15

Liftmaster

Waste handling solutions

There will always be waste, and while we're getting better at separating our general waste, recycling and green waste into different types of bins, a growing population simply means more waste, which leads to more bins. More bins mean an increase in manual waste handling processes, like emptying them into industrial bins or skips.

While some workplaces previously allowed manual lifting of wheelie bins into skips, the rising costs of workplace injuries has led at least one state government department to direct that:

'Wheelie bins are not to be manually lifted into industrial bins ... If wheelie bins are to be emptied into an industrial bin then an appropriate lifting device is to be provided.'

If your workplace still has a manual waste handling problem, it's time to find a solution from Liftmaster's range of Australian made full swing or lift-and-tilt bin lifters, which allow a single operator to lift and empty wheelie bins safely, whilst eliminating the risk of back and side strains caused by lifting heavy bins above shoulder height.





How to choose the right bin lifter

1 Determine the size and weight of your full wheelie bin and how often you'll be tipping

Our range of Australian made bin lifters have models that can lift 80, 120, 140 and 240 litre wheelie bins weighing anywhere from 30–250 kg safely, with assisted lift units that you can safely use up to twice a day, all the way to powered hydraulic units that can lift and tip all day long.



2 Determine how many times a day you'll be tipping

Assisted-lift bin lifters can safely lift their specified weights, but still require manual effort when tipping. So we recommend only using them between two and 10 times a day, per person, depending on the model you choose. If you need to tip more frequently, our powered bin lifters can lift heavier weights more often without the risk of muscle strains.



3 Determine the height of the dumper bin you'll be tipping into

The Niftylift full swing bin lifter and the Ecolift lift-and-tilt bin lifter is suitable for 1500 mm high skip bins. The rest of the range can be configured for use with either 1500 or 1800 mm high skip bins.

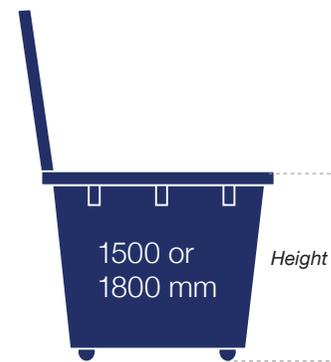



Take a closer look.
Scan the QR code.

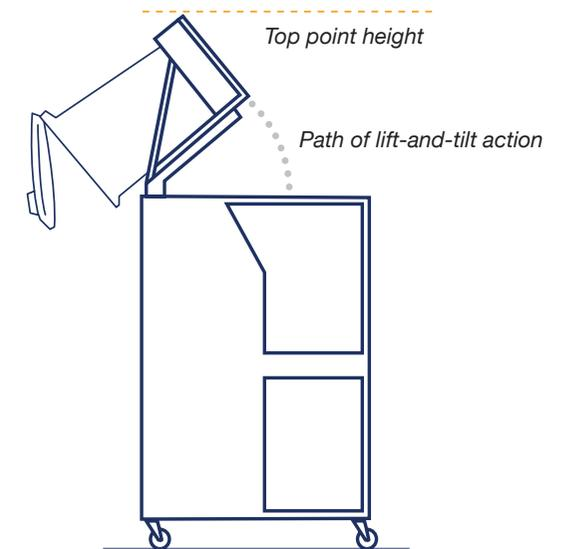
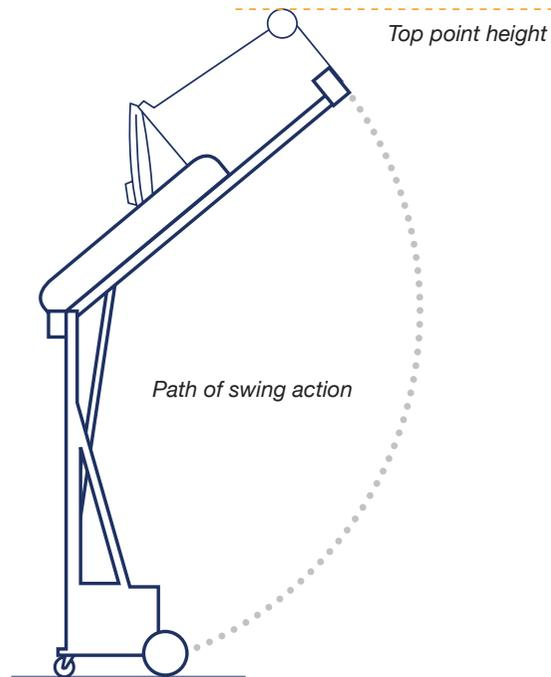

4 Determine the work area and space requirements of the bin lifter

Because of the path of the swing action, full swing bin lifters are only recommended for use in a controlled environment where pedestrian access is restricted. For areas such as schools, retail centres, or anywhere where pedestrian access cannot be restricted, we recommend using a lift-and-tilt model, which encloses the lifting motion within the bin lifter's footprint.

Full swing bin lifters also need more height clearance than lift-and-tilt models so they may not be suitable for low ceiling areas like basements or underground car-parks (see following tables).

For industrial work areas that deal with flammable materials, we recommend using the spark-free full swing Rugged—Manual bin lifter.

Full swing bin lifters

Bin lifter	Order code	Top point height (mm)
Niftylift	NIFTYLIFT30	2850
Rugged—Manual	BLHP1500/BLHP1500LL	3278
	BLHP1800	3752
Rugged—Powered	BLEH1500/BLEH1500LL	3278
	BLEH1800	3752
Rugged (All terrain)	BLHPAT1500/BLEHAT1500	3370

Lift-and-tilt bin lifters

Bin lifter	Order code	Top point height (mm)
Ecolift	ECOLIFT50	2800
Simplicity Plus	SIMPLUS150HY1500	2550
Simplicity Plus	SIMPLUS150HY1800	2800
Universal	UBL250HYD1500	2550
Universal	UBL250HYD1800	2800

Full swing bin lifters

Take a closer look.
Scan the QR code.



Niftylift

- Lifts up to 30 kg safely.
- Suits 1500 mm skip bins.
- Compatible with 120 and 240 litre wheelie bins.
- Manual assisted lift operation with slow release gas struts.
- Recommended for up to two lifts per day, per person.
- Fits through internal doorways.
- Made in Australia.

Order code

Niftylift bin lifter for 1500 mm skip bins

NIFTYLIFT30



Rugged—Manual

- Lifts up to 100 kg safely.
- Models to suit 1500 or 1800 mm skip bins.
- Compatible with 120, 140* and 240 litre wheelie bins.
- Spark-free hydraulic hand-pump operation.
- Recommended for up to 10 lifts per day, per person.
- Fits through internal doorways.
- All-terrain model available for 1500 mm skip bins.
- Made in Australia.

Order code

Rugged—Manual bin lifter for 1500 mm skip bins

BLHP1500

Lid lifter compatible, for 1500 mm skip bins

BLHP1500LL

All terrain model for 1500 mm skip bins

BLHPAT1500

Rugged—Manual bin lifter for 1800 mm skip bins

BLHP1800

* The position of the bin catch must be changed when using 140 litre wheelie bins.



The 'All Terrain' BLHPAT1500 with pneumatic wheels is ideal for outdoor use.



Rugged—Powered

- Lifts up to 150 kg safely, up to 50 times per day.
- Models to suit 1500 or 1800 mm skip bins.
- Compatible with 120, 140* and 240 litre wheelie bins.
- Battery operated push button hydraulic system.
- Fits through internal doorways.
- All-terrain model available for 1500 mm skip bins.
- Made in Australia.

Order code

Rugged—Powered bin lifter for 1500 mm skips

BLEH1500

Lid lifter compatible, for 1500 mm skip bins

BLEH1500LL

All terrain model for 1500 mm skip bins

BLEHAT1500

Rugged—Powered bin lifter for 1800 mm skips

BLEH1800

* The position of the bin catch must be changed when using 140 litre wheelie bins.



The 'All Terrain' BLEHAT1500 with pneumatic wheels is ideal for outdoor use.

Lift-and-tilt bin lifters

Take a closer look.
Scan the QR code.



Ecolift

- Lifts up to 50 kg safely.
- Suits 1500 mm skip bins.
- Compatible with 80, 120, 140 and 240 litre wheelie bins.
- Crank handle winding operation for controlled lifting.
- Recommended for up to six lifts per day, per person.
- Safety cage panels eliminate hand crush points for operators and bystanders.
- Made in Australia.

Order code

Ecolift bin lifter for 1500 mm skip bins

ECOLIFT50



Simplicity Plus

- Lifts up to 150 kg safely.
- Configured to suit 1500 or 1800 mm skip bins.
- Compatible with 80, 120, 140 and 240 litre wheelie bins.
- Battery operated push-button hydraulic system.
- Will lift up to 100 times per day on one charge.
- Safety cage eliminates hand and foot crush points for operators and bystanders.
- Made in Australia.

Order code

Simplicity Plus for 1500 mm skip bins

SIMPLUS150HY1500

Simplicity Plus for 1800 mm skip bins

SIMPLUS150HY1800



Universal

- Lifts up to 250 kg safely.
- Configured to suit 1500 or 1800 mm skip bins.
- Compatible with 80, 120, 140 and 240 litre wheelie bins.
- Battery operated push-button hydraulic system.
- Will lift over 100 times per day on one charge.
- Safety cage and door eliminates all hand and foot crush points for operators and bystanders.
- Made in Australia.

Order code

Universal bin lifter for 1500 mm skip bins

UBL250HYD1500

Universal bin lifter for 1800 mm skip bins

UBL250HYD1800

Wheelie Bin Lid Opener and bins

NEW

A hands-free wheelie bin lid lifter

For use in food, medical and industrial operations the Wheelie Bin Lid Opener bin is the hygienic way to dispose of waste without getting your hands dirty touching the bin.

Simply use the foot pedal to open and close a lidded wheelie bin. Designed and fitted right here in Australia from stainless steel the Wheelie Bin Lid Opener is perfectly suited for fast paced environments where waste needs to be handled quickly and efficiently.

We also offer the Wheelie Bin Lid Opener unassembled so you can purchase in bulk and save in shipping and handling charges.

- The bin can be partially opened (and held in place with your foot) for quick use.
- Fully opened for times when large waste needs to be emptied and closed again with a quick press of the pedal.

Features and benefits

- Australian designed.
- Full stainless steel.
- Can be purchased fully assembled or unassembled.
- Hygienic hands-free operation.
- Can be operated from the front or side.
- Prevents cross contamination from bin to food transfer.
- Costs saving can be achieved by a reduction on handwashing, glove use and hand sanitiser.
- A Wheelie Bin Lid Opener bin can be emptied by a Liftmaster bin lifter into a bulk bin.
- Can be picked up and emptied by a waste bin truck in the usual weekly/daily collection.
- Compatible with 80, 120 and 240 litre wheel bins.
- Designed to be used only on Sulo and Schaefer bins.

Typical applications

- Commercial kitchens and food preparation areas.
- Washrooms and bathrooms.
- Medical and healthcare facilities.
- Industrial and construction.
- Any commercial or residential site where emptying waste safely is required.

Wheelie Bin Lid Opener kit

The kit consists of:

- A foot pedal frame and vertical bars.
- Hinges.
- Nuts and bolts.



Order codes

Wheelie Bin Lid Opener kit options	Bin size	Order code
Kit sold separately. For fitting to your existing wheelie bin.	80 litres	SPLIFTALID80
	120 litres	SPLIFTALID120
	240 litres	SPLIFTALID240
Unassembled kit with wheelie bin. Ideal for buying in bulk.	80 litres	SPLIFTALID80UN
	120 litres	SPLIFTALID120UN
	240 litres	SPLIFTALID240UN
Pre-assembled kit fitted to a wheelie bin.	80 litres	SPLIFTALID80AS
	120 litres	SPLIFTALID120AS
	240 litres	SPLIFTALID240AS

Wheelie bin options	Bin size	Order code
80 litre wheelie bin. Dimensions (H x D x W): 825 x 496 x 440 mm	80 litre	80LTBIN
120 litre wheelie bin. Dimensions (H x D x W): 925 x 555 x 480 mm	120 litre	120LTBIN
240 litre wheelie bin. Dimensions (H x D x W): 1060 x 730 x 550 mm	240 litre	240LTBIN
360 litre wheelie bin*. Dimensions (H x D x W): 1116 x 904 x 669 mm	360 litre	360LTBIN

Spare parts	Order code
Wheelie bin wheels (For more info, see page 60).	RPL200(DTR)

* The 360LTBIN is a special order. We do not stock this item.





Easy installation steps

If you purchase the kit unassembled, please follow our easy installation steps for fitting to your existing wheelie bin.

Tools required for assembly:

- Flat blade screwdriver.
- 5 mm Allen key.
- Shifter.



- 1** Simply remove the wheels from the bin, using a screwdriver.



- 2** Insert the wheel's axle into the foot pedal frame (ensuring the frame is the right way up.)



- 3** Remove the hinge pins from the lid.



- 4** Align the Wheelie Bin Lid Opener hinges, then reinsert the lid hinge pins.



- 5** Attach the foot pedal bars to the lid hinges using the bolts.



- 6** Tighten using your shifter.



- 7** Then at the base of the bin, attach the foot pedal frame to the vertical bars using the nuts and bolts provided.



- 8** Tighten using your Allen key and shifter. Your bin is now ready to use.



Bin movers

Manually moving heavy wheelie bins can increase the risk of strains and injuries.

Our bin mover range offers a smart solution for moving multiple bins to a central waste location.

Take a closer look.
Scan the QR code.



Modular Bin Trailer: Three bin model (MODULAR3) with optional tow ball coupling shown.



Modular Bin Trailer: Six bin model (MODULAR6)

Powered Bin Trolley by Electrodrive

- Move up to three 240 litre wheelie bins, weighing up to 400 kg over a flat surface.
- Powered drive wheel can carry loads over ramps up to 5°.
- Smart design with easy turning action.
- Tiller control keeps you in front of load.
- Made in Australia.

Order code

Powered Bin Trolley

POWBINTROLLEY

Modular Bin Trailer

- Available in three and six bin models.
- Load capacity of up to 240 kg per bin bay.
- Compatible with 80, 120, 140, 240 and 360 litre wheelie bins.
- Gas strut actuated bin ramp.

Order code

Three bay trailer for 80–360 litre wheelie bins

MODULAR3

- Fits within one standard car parking space.
- Comes with a pin-hitch coupling as standard.
- Also available with tow ball or bar hitch couplings.
- Made in Australia.

Please note: These units are supplied flat-packed ready for assembly.

Order code

Six bay trailer for 80–360 litre wheelie bins

MODULAR6

Strong Arm hoist

The Strong Arm is a cantilever crane designed to be statically bolted to a concrete floor (such as a loading bay).

An integral piece of plant equipment used for lifting loads between floors, while effectively eliminating the need for manually carrying heavy, bulky equipment on stairs, or the use of a forklift.

A hand winch is low-g geared to ensure loads of up to 500 kg can be easily raised, while precise positioning of the load is achieved through geared hand-slewing of the mast.

Extra lift height can be achieved by raising the boom (prior to lifting the load).

The mast is fitted to the base plate with two pins. Remove the first pin and the mast can be folded down for easy travel. Remove the second (pivot) pin and the Strong Arm can be stowed away.

It is suitable for plant equipment, workshops, manufacturing, factories.

Features

- Lifts up to 500 kg safely.
- Hand winch operation.
- Can be folded for storage.

Dimensions (L/W/H)	1171/508/1557 mm
--------------------	------------------

Load capacity	500 kg
---------------	--------

Please note:

Supply only. Fitting is as per specific site requirements.

Onsite installation and mounting must be done by a qualified engineer.

Take a closer look.
Scan the QR code.



NEW

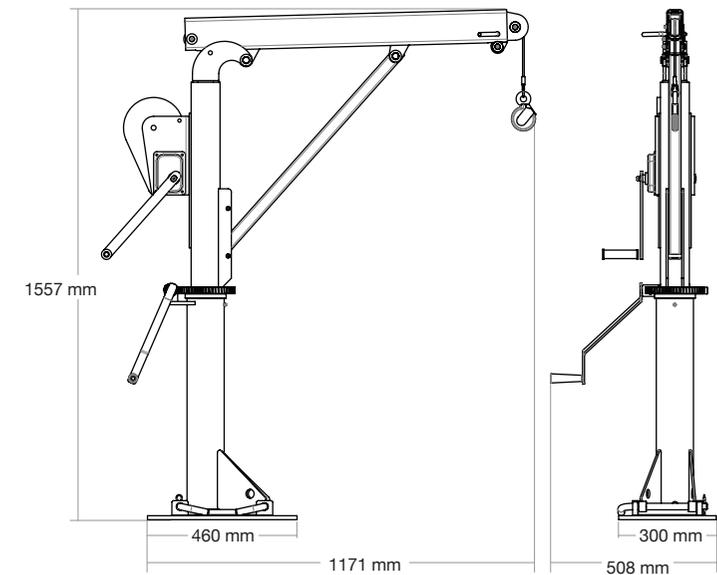

Order code

Strong Arm hoist 500 kg

SIS4HW



Castors & Industrial

Materials handling equipment

Castors & Industrial have been at the forefront of castors and materials handling equipment distribution in Queensland since 1997.

In 2015, Castors & Industrial joined the Fallshaw Group, with team members bringing more than 40 years of combined experience and product knowledge, along with their extensive catalogue of materials handling equipment.

Specialising in standard and custom manufactured gravity conveyor systems and rollers, standard and custom manufactured lift tables, pallet positioners, battery powered and manually operated mobile scissor lifts, pallet trucks, hand trucks, adjustable feet and tube ends—as well as the entire Fallshaw Group catalogue at their disposal—the team at Castors & Industrial will ensure you have the right equipment for the job at hand.

Gravity conveyors

A gravity conveyor is ideally suited for handling operations which cannot justify the expense of powered equipment.

They provide an efficient and economical way to move manufactured goods from one process to the next, increasing your productivity and reducing labour costs.

Gravity conveyors are also very easy to set up, dismantle or relocate. They work on one of the following principles:

- One stand is lower than the other, and gravity moves the load.
- The frame is level, and the load is pushed along.

Gravity conveyor frames, rollers and supports are available in a variety of standard sizes and configurations.

Take a closer look.
Scan the QR code.



How to choose

1. Item size

Measure the dimensions (length x width) and weight of the largest and smallest items to be carried on the conveyor, to ensure there are three rollers under the item at all times for stability.

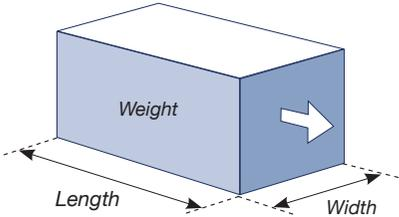

2. Frame width and length

Choose the frame width closest to the width of the items being conveyed. The rollers sit 10 mm above the roller frame. Overhang should be minimal.

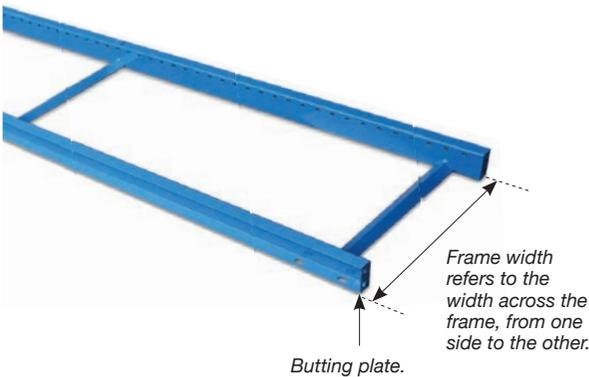

3. Rollers

The product being conveyed determines which rollers are best for your application.

Medium heavy duty steel rollers are generally used for the conveying of heavy boxes and lengths of steel, whereas polypropylene rollers are more suitable for lightweight boxes and items you don't want marked, such as aluminium.



4. Supports

The conveyor supports are RHS steel construction, height adjustable from 600 to 900 mm (1000 mm to top of roller when fully extended) and have a Hammertone Regal Blue painted finish.

Supports can be bolted to the floor and to the conveyor system for added stability. Support can also be ordered with capped ends with a single hole to allow castors to be fitted.



FRAMES

Australian manufactured conveyor frames

Frames are all laser cut (matched) C-channels with fully-welded cross braces. Butting plates on ends are integral and folded as part of the laser process.

Three standard frame widths:

- 305, 460 and 610 mm (measurement is over the frame).

Two standard frame lengths:

- 1500 and 3000 mm.

Medium heavy duty frames can only be supplied with MHDGAL or POLY rollers with 3/8" round shafts. Heavy duty frames can only be supplied with HD rollers with 12 mm round shafts.

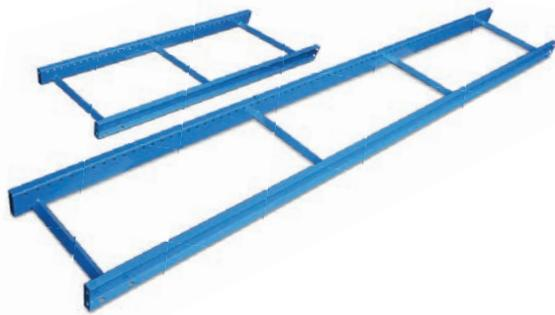

Features

- Frames have fully welded cross braces (frames are not bolted together).
- Frames have laser cut holes at 79 mm and 115 mm pitch as standard, with laser cut holes in the bottom of the channels to allow supports to be mounted in three positions (each end and at mid-span on the 3 m frames) and two positions (each end on a 1.5 m frame).
- Each end of the folded butting plates are pre-drilled to allow splicing together.
- The tops of the frames have holes pre-drilled to allow for the mounting of guide rails if required.
- Painted Hammertone Regal Blue painted finish.

Medium heavy duty (MHD)

1500 mm long x 2.5 mm thick gravity conveyor frame.

Overall frame width (mm)	Inside frame width (mm)	Order code
305	242	CF15X305MHD
460	394	CF15X460MHD
610	546	CF15X610MHD

Medium heavy duty (MHD)

3000 mm long x 2.5 mm thick gravity conveyor frame.

Overall frame width (mm)	Inside frame width (mm)	Order code
305	242	CF3X305MHD
460	394	CF3X460MHD
610	546	CF3X610MHD

Heavy duty (HD)

1500 mm long x 2.5 mm thick gravity conveyor frame.

Overall frame width (mm)	Inside frame width (mm)	Order code
305	242	CF15X305HD
460	394	CF15X460HD
610	546	CF15X610HD

Heavy duty (HD)

3000 mm long x 2.5 mm thick conveyor frame.

Overall frame width (mm)	Inside frame width (mm)	Order code
305	242	CF3X305HD
460	394	CF3X460HD
610	546	CF3X610HD

SUPPORTS

RHS supports are bolted to the frame through a crescent plate which allows for angular alignment. They have a strong, rigid construction, making them suitable for more permanent conveyors.

Straight frames require only one support per join (ie, three supports for two frames). However, if the frames are to be moved, it is usually more convenient to have a support at each end (ie, four supports for two frames).

Features

- RHS construction.
- Height is adjustable from 600 to 900 mm (1000 mm to top of roller when fully extended).
- Hammertone Regal Blue painted finish.
- Supports can be bolted to the floor and to the conveyor system for added stability.
- Supports can be ordered with capped ends and a single hole to allow castors to be fitted.

Standard sizes



Suits conveyor frame width (mm)	Order code
305	CS305
460	CS460
610	CS610

ROLLERS

Rollers can be supplied in:

- 1.6 mm wall medium heavy duty galvanized steel tube.
- 2.8 mm wall polypropylene tube.
- 2 mm wall heavy duty galvanized steel tube.

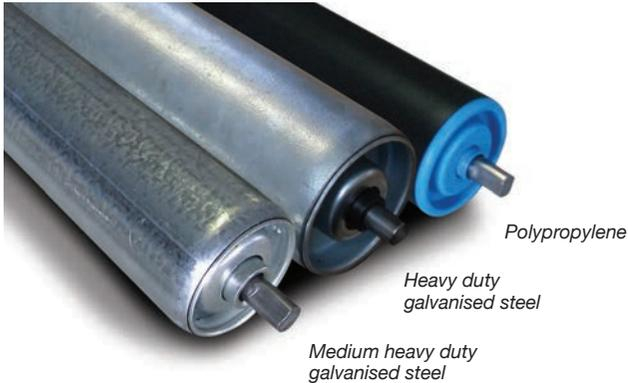

Medium heavy duty (MHDGAL)

- 50 mm diameter x 1.6 mm wall galvanized steel tube.
- 3/8" diameter spring loaded mild steel, round shaft with 'D' one end.
- Unground steel bearings.
- 15 mm shaft protrusion each end of bearing.

Overall frame width (mm)	Inside frame width (mm)	Over bearing length (mm)	Order code
305	242	240	CR240MHDGAL
460	394	392	CR392MHDGAL
610	546	544	CR544MHDGAL

Heavy duty (HDGAL)

- 50 mm diameter x 2 mm wall galvanized steel tube.
- 12 mm diameter spring loaded mild steel, round shaft.
- Precision bearings.
- 15 mm shaft protrusion each end of bearing.

Overall frame width (mm)	Inside frame width (mm)	Over bearing length (mm)	Order code
305	242	240	CR240HDGAL
460	394	392	CR392HDGAL
610	546	544	CR544HDGAL

Polypropylene (POLY)

- 50 mm diameter x 2.8 mm wall polypropylene tube.
- 3/8" diameter spring loaded mild steel, round shaft with 'D' one end.
- Plastic caged bearings.
- 15 mm shaft protrusion each end of bearing.

Overall frame width (mm)	Inside frame width (mm)	Over bearing length (mm)	Order code
305	242	240	CR240POLY
460	394	392	CR392POLY
610	546	544	CR544POLY



CUSTOM

Custom manufactured conveyor frames, rollers and supports

We can supply gravity conveyor frames manufactured at 1500 mm long in standard widths of 305, 460 or 610 mm. We can also manufacture conveyor frames, rollers and supports to suit your criteria.

Conveyor rollers can be manufactured in various diameters and lengths with a variety of shaft configurations. Speak to our technical team to obtain pricing on your requirements.

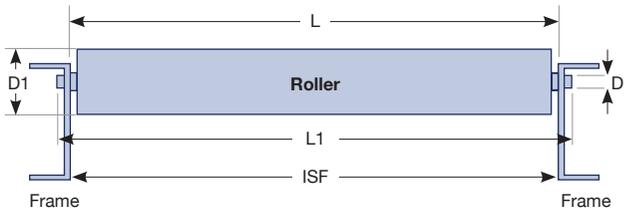

Measurements required for custom orders	(mm)
Inside frame (ISF)	
Over bearing (L)	
Overall axle (L1)	
Shaft diameter (D)	
Roller diameter (D1)	



Gravity conveyor packages

Medium heavy duty gravity conveyor packages

Frames

Frames are all laser cut (matched) C-channels with fully-welded cross braces. Butting plates on ends are integral and folded as part of the laser process. Frames have laser cut holes in the bottom of the channels to allow for supports to be mounted in three positions (each end and at mid-span on the 3 m frames) and two positions (each end) on a 1.5 m frame. Hammertone Regal Blue painted finish.

Rollers

Galvanized steel tube rollers, round shaft with a 15 mm shaft protrusion each end of roller, 'D' one end, unground steel bearings.

Dimensions:

- 50 mm diameter x 1.6 mm wall.
- 3/8" diameter spring loaded mild steel.

Supports

- RHS construction, with height adjustable from 600–900 mm (1000 mm to top of roller when full extended).
- Can be bolted to floor and conveyor system for added stability.

Load capacity (kg)	Overall frame width (mm)	Inside frame width (mm)	Frame length (mm)	Frame	Rollers	Roller pitch	Supports	Order code
150	305	242	3000	1	38	79	2	CP3X305-79
150	460	394	3000	1	38	79	2	CP3X460-79
150	610	546	3000	1	38	79	2	CP3X610-79
200	305	242	3000	1	38	79	3	CP3X305-79/3
200	460	394	3000	1	38	79	3	CP3X460-79/3
200	610	546	3000	1	38	79	3	CP3X610-79/3
150	305	242	3000	1	26	115	2	CP3X305-115
150	460	394	3000	1	26	115	2	CP3X460-115
150	610	546	3000	1	26	115	2	CP3X610-115
200	305	242	3000	1	26	115	3	CP3X305-115/3
200	460	394	3000	1	26	115	3	CP3X460-115/3
200	610	546	3000	1	26	115	3	CP3X610-115/3

Heavy duty gravity conveyor packages

Frames

Frames are all laser cut (matched) C-channels with fully-welded cross braces. Butting plates on ends are integral and folded as part of the laser process. Frames have laser cut holes in the bottom of the channels to allow for supports to be mounted in three positions (each end and at mid-span on the 3 m frames) and two positions (each end) on a 1.5 m frame. Hammertone Regal Blue painted finish.

Rollers

Galvanized steel tube rollers, round shaft with a 15 mm shaft protrusion each end of roller and precision bearings.

Dimensions:

- 50 mm diameter x 2 mm wall.
- 12 mm diameter spring-loaded mild steel.

Supports

- RHS construction, with height adjustable from 600–900 mm (1000 mm to top of roller when full extended).
- Can be bolted to floor and conveyor system for added stability.

Load capacity (kg)	Overall frame width (mm)	Inside frame width (mm)	Frame length (mm)	Frame	Rollers	Roller pitch	Supports	Order code
250	305	242	3000	1	38	79	2	CP3X305HD-79
250	460	394	3000	1	38	79	2	CP3X460HD-79
250	610	546	3000	1	38	79	2	CP3X610HD-79
300	305	242	3000	1	38	79	3	CP3X305HD-79/3
300	460	394	3000	1	38	79	3	CP3X460HD-79/3
300	610	546	3000	1	38	79	3	CP3X610HD-79/3
250	305	242	3000	1	26	115	2	CP3X305HD-115
250	460	394	3000	1	26	115	2	CP3X460HD-115
250	610	546	3000	1	26	115	2	CP3X610HD-115
300	305	242	3000	1	26	115	3	CP3X305HD-115/3
300	460	394	3000	1	26	115	3	CP3X460HD-115/3
300	610	546	3000	1	26	115	3	CP3X610HD-115/3

Lift tables

Features and options

- Our lift table range can be used in above-floor or in-floor pit applications.
- The upper platforms are fitted with an aluminium safety bar which prevents descent on contact with obstructions.
- Button-operated and easy-to-use.
- Low-tension (24V) control box with up-down buttons.
- Power source: 240V single phase or 415V 3 phase.
- Internal power pack equipped with relief valve against overloading and compensated flow valve for controlled lowering speed.
- Heavy duty cylinders with drainage system and check valve to stop the table lowering in case of a hose bursting.
- Removable eyelets for lifting.
- Please expect a **6-8 week lead time** from the date of placing your order.

Take a closer look.
Scan the QR code.



Single scissor lift tables

- Lifts up to 3000 kg.

Order code	LT500IM	LT1000IM	LT2000IM	LT3000IM
Lowered height (mm)	190	190	190	220
Raised height (mm)	1010	1010	1010	1020
Platform size L x W (mm)	1300 x 800			
Lifting time (seconds)	15	25	24-28	26
Lifting speed with load (sec)	55	40	24-28	30
Lowering speed with load (sec)	40	35	11-15	40
Motor (kw)	0.75	0.75	0.75	1.5
Net weight (kg)	160	220	280	320
Load capacity (kg)	500	1000	2000	3000



Double scissor lift tables

- Lifts up to 4000 kg.

Order code	LTDS1000IM	LTDS2000IM	LTDS4000IM
Lowered height (mm)	305	360	400
Raised height (mm)	1780	1780	2050
Platform size L x W (mm)	1300 x 820	1300 x 850	1700 x 1200
Base frame size (mm)	1240 x 640	1220 x 785	1600 x 900
Lifting time (seconds)	35-45	35-45	55-65
Net weight (kg)	210	295	520
Load capacity (kg)	1000	2000	4000



Extra wide single scissor lift tables

- Lifts up to 4000 kg.

Order code	LTW2000IM	LTW4000IM
Lowered height (mm)	205	230
Raised height (mm)	1000	1000
Platform size L x W (mm)	2500 x 820	2500 x 850
Net weight (kg)	265	360
Load capacity (kg)	2000	4000

For more information, please see page 110.

Hospital bed maintenance lift

The LT600HBML hospital bed maintenance lift is designed to fit all hospital beds including bariatric beds weighing up to 600 kg.

Powered by an electric hydraulic lift, its remote control enables easy access for hospital maintenance or engineering staff to carry out servicing or maintenance repairs safely.

Features and options

- Anti-slip/non-skid chequer plate platform.
- Safety lip (20 mm) on three sides of platform (excluding ramp end) to prevent hospital beds from falling.
- Expandable table configuration.
- Side table extensions.
- Add-on front deck to accommodate custom length beds.
- Electric hydraulic lift remote control.
- Hydraulic direct-drive cylinders, designed and made on ANSI standard, utilising oil seal in cylinder.
- Self-lubricating UHMW polyethylene sliders and bronze bush.
- Width Extension Kit for an additional 600 mm.
- Made to order, with a lead time **between 8–10 weeks**.

Order code	LT600HBML
Lift time	23 seconds
Lowered height	155 mm
Raised height	1090 mm
Overall length	2755 mm
Deck type	Chequer plate
Motor	1.5 HP
Power	240V mains power operated
Lift capacity	Up to 600 kg



An example of Hospital Bed Maintenance Lift with the Width Extension Kit, adding 300 mm to each side.



The Width Extension Kit.

Custom manufactured lift tables

Our hydraulic lift tables are designed for safety and are offered with an extensive range of capacities, features and options to provide your factory or warehouse with safe and efficient lifting and work positioning.

Smartlift controls are supplied as standard across the range, providing automatic down-indexing, electronic diagnostics and enhanced safety features.

Features and options

- Smartlift controls.
- Available with manual turntables to rotate the load.
- Available with high cycle capacity.
- Available with safety bars or skirts to protect operators.
- Can be adapted for use as personnel lifts, fabrication bench, or assembly bench.
- Can be customised with multiple hand or foot controls, automation, on-board power outlets, or interlocks with associated equipment.
- Designed to exceed industry safety standards.
- Made in Australia.



These lift tables are custom manufactured to suit your criteria (with a **6-10 week lead time**).

In order for these units to be quoted to you correctly, we need to gather a comprehensive list of information from you to ensure you have the right unit for the right application, including:

Capacity of lift table	Is a safety concertina skirt required?
Platform size	Do you have access to both 240 Volt and 3 phase power?
Vertical travel	Will you be loading the lift table with a forklift or pallet truck?
Extended height	Will personnel be riding on the platform?
Minimum height (if critical)	How many starts per hour will the unit require?
Type of environment unit will be working in (for example: Outside, factory, cold room).	How many full cycles per hour? (every up cycle is a motor start, full up and down cycle).
Will the load be evenly distributed?	Will the lift table be working in conjunction with your machinery?
Do you require foot switch controls or a hand pendant control?	Do you require the lift table to move up and down in small increments?

Pallet positioners

Resembling a scissor lift table in appearance, pallet positioners have a top deck and a base connected by a pair of scissor legs. The levelling mechanism is a set of springs set to the weight and height of the product.

Pallet positioners work by compressing or decompressing the spring which in turn lowers or raises the load as the weight changes.

Features across the range

- Load setting is a simple process.
- Available in powder-coated safety yellow or galvanized finish.
- Dramatically reduces the effort required to pack palletised goods.
- Built in turntable allows simple load rotation and access to all sides.
- Durable and tough, these pallet positioners can be used in a wide range of applications.
- Automatically keeps pallet or stillage loads at an optimum working height when loading or unloading goods.
- Supplied with three springs as standard.

Take a closer look.
Scan the QR code.



NEW



PL2000P

- Powder-coated safety yellow finish.
- Lifts up to 2000 kg.

Order code	PL2000P
Platform diameter	1110 mm
Height range	240-705 mm
Base size	920 x 930 mm
Net weight	105 kg
Load capacity	2000 kg

PL2000G

- Galvanised finish.
- Lifts up to 2000 kg.

Order code	PL2000G
Platform diameter	1110 mm
Height range	240-705 mm
Base size	920 x 930 mm
Net weight	105 kg
Load capacity	2000 kg

Battery powered mobile scissor lifts

Powerlift mobile scissor lifts provide lifting at the push of a button. They eliminate the need for manual pumping to provide users with a safe, clean powered lift that is quiet and suited to areas where hydraulics cannot be used.

Powered mobile scissor lifts use a linear actuator (rated IP54) as the lifting mechanism, and a specially developed battery box that powers up to 150 lifts per charge. This eliminates hydraulic fluids or oils and provides a quiet, steady lift force. A high duty cycle, rechargeable battery supplies the power and a push button controller makes operating the Powerlift trolleys effortless to use.

Customisation is also available.

Features across the range

- Highly manoeuvrable and easy to steer.
- Push button control.
- Powder-coated for a quality finish.
- Up to 150 lifts per charge.
- Large diameter, low friction, non-marking grey polyurethane castors for easy manoeuvrability.
- High duty cycle, 240V rechargeable 12 volt battery.
- No power lead drag.
- No manual pumping.
- Made in Australia.

Applications

- Ideal for offices, factories, vets, medical clinics.
- Suitable for applications where hydraulic contaminants can't be tolerated.

Additional options

- IP56 rated actuators are suitable for washdown.
- Static base frame can be supplied for use as a stable lifting platform.
- 240V rechargeable 12V battery.



SLB100

- Lifts up to 100 kg.
- Double scissor lift.

Order code	SLB100
Platform size	895 x 480 mm
Height range	505–1505 mm
Elevation time	20 sec
Unit weight	50 kg
Load capacity	100 kg



SLB250

- Lifts up to 250 kg.
- Single scissor lift.

Order code	SLB250
Platform size	895 x 480 mm
Height range	365–855 mm
Elevation time	20 sec
Unit weight	43 kg
Load capacity	250 kg

Mobile scissor lifts

Our mobile scissor lifts are ergonomically designed with a manual foot pump to elevate the table height, reducing strain and fatigue from bending over and a hand operated release allows the platform to lower in a controlled manner.

Features across the range

- Rear braking system.
- Overload by-pass valve.
- Manual push, precision hydraulic foot pump and quick release system.
- Lockable swivel polyurethane castors with toe guard.
- Hand release lever to lower the table to preferred height.
- Easy to use foot pump allows user to lift to desired height.
- Powder-coated safety yellow for high visibility and extra protection from wear and tear.
- Mobile scissor lifts feature safety restraint bars that lock the platform into the fully raised position.

Applications

- Ideal for picking in a warehouse or process work.



SLM150

- Single scissor lift.

Order code	SLM150
Platform size	700 x 450 mm
Height range	220—750 mm
Handle height	950 mm
Castor wheel diameter	100 mm
Foot pumps to maximum height	16
Unit weight	49 kg
Load capacity	150 kg



SLM200

- Large base with solid rubber wheels

Order code	SLM200
Platform size	1000 x 500 mm
Height range	390—1000 mm
Handle height	1100 mm
Castor wheel diameter	200 mm
Foot pumps to maximum height	26
Unit weight	60 kg
Load capacity	200 kg



SLM350

- Double scissor lift

Order code	SLM350
Platform size	910 x 500 mm
Height range	355—1300 mm
Handle height	975 mm
Castor wheel diameter	125 mm
Foot pumps to maximum height	53
Unit weight	105 kg
Load capacity	350 kg



SLMV500

- Single scissor lift
- Suitable for veterinaries.

Order code	SLMV500
Platform size	1600 x 810 mm
Height range	286—915 mm
Handle height	990 mm
Castor wheel diameter	127 mm
Foot pumps to maximum height	45
Unit weight	155 kg
Load capacity	500 kg



SLM1000

- Single scissor lift

Order code	SLM1000
Platform size	1000 x 510 mm
Height range	390—1000 mm
Handle height	1020 mm
Castor wheel diameter	150 mm
Foot pumps to maximum height	72
Unit weight	110 kg
Load capacity	1000 kg

Mobile scissor lifts



SLM1000H

- Double scissor lift

Order code	SLM1000H
Platform size	1200 x 610 mm
Height range	500—1500 mm
Handle height	1020 mm
Castor wheel diameter	150 mm
Foot pumps to maximum height	150
Unit weight	160 kg
Load capacity	1000 kg

Safety steps



Safety step

- Mobile safety step with spring-loaded castors.
- Durable one piece plastic construction with anti-slip surface.

Order code	SS
Height	395 mm
Platform diameter	315 mm
Unit weight	4.2 kg
Load capacity	180 kg



Square safety step

- Large safety step with rubber feet for safety.
- Durable one piece plastic construction with anti-slip surface.

Order code	SQSSMON
Height	375 mm
Platform size	370 x 370 mm
Unit weight	3.5 kg
Load capacity	180 kg

Pallet trucks

Features across the range

- Totally sealed hydraulic pump with a slow lowering hand control valve.
- Fully adjustable push rod under forks.
- Grease fittings at key point.
- Powder-coated safety yellow for high visibility and extra protection from wear and tear.
- Entry and exit rollers prevent physical exertion of the operator and protect load roller and pallet.
- The entry rollers are located on the front edge of each fork to assist in clean pallet entrance and exit.
- These units make it easy for one person to move extra large and bulky loads.
- Three-position control handle, lower, neutral and lift.
- Steel construction.



Standard pallet truck

- Lifts up to 2500 kg.
- Three sizes: 450 mm, 520 mm and 685 mm wide.

Order codes	PT450 / PT520 / PT685
Fork height range (minimum to maximum)	85–200 mm (PT450) 75–190 mm (PT520) 75–190 mm (PT685)
Fork (length x width)	1150 x 160 mm
Overall fork width	450 mm (PT450) 520 mm (PT520) 685 mm (PT685)
Unit weight	70 kg
Load capacity	2500 kg

Low profile pallet truck

- Lifts up to 1000 kg.
- 540 mm wide.

Order code	PTLP300
Fork height range (minimum to maximum)	35–90 mm
Fork (length x width)	1120 x 160 mm
Overall fork width	540 mm
Unit weight	75 kg
Load capacity	1000 kg



Wide pallet truck

- Lifts up to 2500 kg.
- 900 mm wide.

Order code	PTW900
Fork height range (minimum to maximum)	75–190 mm
Fork (length x width)	1150 x 160 mm
Overall fork width	900 mm
Unit weight	90 kg
Load capacity	2500 kg



Long pallet truck

- Lifts up to 2000 kg.
- 2400 mm long.

Order code	PTL685
Fork height range (minimum to maximum)	85–200 mm
Fork (length x width)	2400 x 160 mm
Overall fork width	685 mm
Unit weight	120 kg
Load capacity	2000 kg



Short pallet truck

- Lifts up to 2500 kg.
- 800 mm long.

Order code	PTS450
Fork height range (minimum to maximum)	80–190 mm
Fork (length x width)	800 x 160 mm
Overall fork width	450 mm
Unit weight	60 kg
Load capacity	2500 kg

Industrial trolleys

Features across the range

- 150–520 kg load capacity.
- Heavy duty construction.



General duty platform trolley

- Fold-down handle.
- Low maintenance non-slip vinyl deck with rubber bumper.
- Powder-coat finish.
- Carries up to 150 kg.
- Supplied flat packed.

Order code	IT150
Platform size	740 x 480 mm
Handle height	1000 mm
Castors	100 mm diameter grey rubber. Two swivel, two fixed.
Unit weight	11 kg
Load capacity	150 kg

Heavy duty platform trolley

- Bolted on handle.
- Low maintenance non-slip vinyl deck with rubber bumper.
- Powder-coat finish.
- Carries up to 500 kg.
- Supplied flat packed.

Order code	IT500
Platform size	1170 x 765 mm
Handle height	865 mm
Castors	200 mm diameter black rubber/spoked rim. Two swivel, two fixed.
Unit weight	35 kg
Load capacity	500 kg



Powder-coat platform trolley

- Welded fixed handle.
- Powder-coat finish.
- Carries up to 520 kg.
- Six castors.

Order code	IT520
Platform size	1200 x 700 mm
Handle height	1020 mm
Castors	150 mm polyurethane on nylon, four swivel, two fixed.
Load capacity	520 kg



Caged trolley

- Heavy duty trolley with full mesh sides and fold down gate.
- Grey powder-coat finish.
- Fully welded.

Order code	ITC340
Platform size	900 x 600 mm
Platform height	155 mm
Handle height	930 mm
Castors	100 mm diametre grey non-marking rubber, two swivel, two fixed.
Load capacity	340 kg



Two tier trolley with top basket

- Grey powder-coat finish.
- Fully welded.

Order code	IT2TC340
Platform size	900 x 600 mm
Base platform height	155 mm
Handle height	930 mm
Height between levels	400 mm
Depth of basket	240 mm
Height to top of basket	840 mm
Load capacity	340 kg



Two tier platform trolley

- Two tier trolley with non-slip vinyl decks.
- Rubber bumper on both decks.
- Supplied flat-packed.
- Low maintenance.

Order code	IT220
Length x width	785 x 485 mm
Height	860 mm
Castor diameter	100 mm (two swivel and two fixed)
Load capacity	220 kg



Three tier platform trolley

- Three-tier trolley.
- Non-slip vinyl decks with rubber bumper on all decks.
- Supplied flat-packed.
- Low maintenance.

Order code	IT170
Length x width	785 x 485 mm
Height	1000 mm
Castor diameter	100 mm (two swivel and two fixed)
Load capacity	170 kg



Galvanised stock room trolley

- Galvanised flat-bed trolley for increased corrosion resistance.
- Suitable for harsh environments.
- Ideal for coolroom and refrigerated use, greengrocers and supermarkets.

Order code	IT450
Length x width	990 x 460 mm
Height	950 mm
Castor diameter	125 mm (four swivel)
Centre wheels	200 mm (non-marking)
Load capacity	450 kg

Container skates

NEW

- Container skates are easy and convenient to use, they can manoeuvre a container into a position where a forklift can't go.
- Container skates are ideal for ISO container transport.
- The double roller design results in easy steering due to reduced friction forces.
- Interlocking and force fit between the roller skates and the container.
- Twist locks are used on the front and back to lock and secure the container onto the skate system.

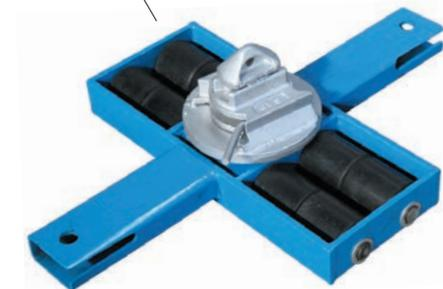
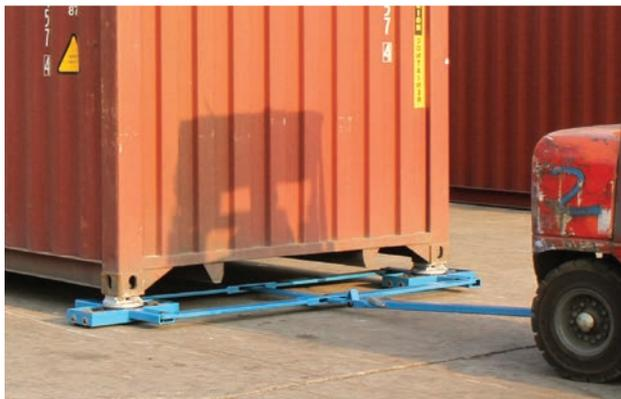

Order code	CS32SET
Deck height	155 mm
Handle	Can be turned to a maximum of 45 degrees left or right
Turning circle	<ul style="list-style-type: none"> ▪ 20' container, radius of turning circle is 6 m. ▪ 40' container, radius of turning circle is 10 m.
Suitability	ISO containers
Wheels	Nylon (smooth and easy run on concrete floors.)
Optional	Polyurethane wheels

Hand trucks

Features across the range

- Powder-coated.
- RHS and structural steel frames.
- Heavy duty construction.
- Pneumatic wheels.



Box n' bag

- Ideal for heavy loads of boxed and bagged products.
- The axle is specifically designed for load-bearing and easy-tilting, doing the heavy work for you.
- Multi-grip loop handle.

Order code	HTBNB
Frame size (L x W)	1290 x 370 mm
Base plate size (L x W)	430 x 240 mm
Load support	Full height, flat surface RHS frame for secure support of double box stacks. (eg. Safely move 13 cartons of beer instead of 7 cartons with most other trolleys).
Wheels	265 mm diameter x 70 mm wide black pneumatic on steel rim
Trolley weight	22 kg
Load capacity	300 kg

All rounder

- Multipurpose trolley, excellent for moving heavy drums, barrels, tubs, gas cylinders, garden ornaments, truck parts, paint cans, appliances and large boxed goods.
- Specifically designed load-bearing and easy-tilting axle.
- Ergonomic hand grips.

Order code	HTAR
Frame size (L x W)	1400 x 370 mm
Base plate size (L x W)	430 x 240 mm
Load support	Curved support with 60 mm set back. Adjustable drum holding hook or optional tub holding hook. <i>If no hook is required, simply rotate the mounting collar sideways out of the way.</i>
Wheels	265 mm diameter x 70 mm wide black pneumatic on steel rim
Trolley weight	20 kg
Load capacity	300 kg



Super mover

- Tall and strong trolley for safely moving big refrigerators, freezers, ATM machines, game machines, tyres, large hot water cylinders, heavy gas cylinders, furniture, etc.
- Specifically designed load-bearing and easy-tilting axle.
- Two hand grip levels.

Order code	HTSP
Frame size (L x W)	1560 x 430 mm
Base plate size (L x W)	430 x 240 mm
Load support	Flat
Wheels	320 mm diameter x 80 mm wide black pneumatic on steel rim
Trolley weight	28 kg
Load capacity	300 kg

Drum handling



Tilting drum stand

- Supplied flat packed.
- Perfect for manoeuvring drums and decanting.
- Handles can be extended and retracted.
- Steel construction.
- Plastic hand grips on handles.

Order code	HTTDS
Suits drum type	210 litre
Load capacity	170 kg
Front wheels	125 mm diameter
Rear castors	100 mm diameter
Unit weight	14.5 kg



Drum dolly

- Drum dolly allows for convenient portability.
- Easy bolt together assembly.
- All welded steel frame with polyurethane castors.
- Powder-coated safety yellow for high visibility and extra protection from wear and tear.
- Wheels are set on the outer rim for a more even balance of the drum when moving and a less chance of the drum tipping.

Order code	DD610ID
Inner diameter	610 mm
Height	155 mm
Castors	75 mm
Unit weight	7 kg
Suits	208 litre drum
Capacity	400 kg

NEW

Follow-Me Trolley

The Follow-Me Trolley is a highly manoeuvrable flatbed trolley with an articulation system inspired by B-Double trailers and road trains.

Designed with a quick hitching mechanism, each trolley can be easily hitched into a train where it mimics the movement of the object directly in front, giving the whole train a very tight turn circle and allowing it to negotiate tight corners and S-bends.

Combined with an Electrodrive powered tug, up to 10 fully loaded Follow-Me Trolleys can be towed safely by one person through tight shopping aisles.

Take a closer look. Scan the QR code.



Pictured: A chain of Follow-Me Trolleys hitched to the Tug Compact (can be ordered separately).

Designed for the smallest tug in our range, the Tug Compact (with its width of only 609 mm) allows it to comfortably fit through doorways and corridors.

Features

- High manoeuvrability of trolley trains through tight corners and S-bends.
- Quick release levers for easy hitching and unhitching.
- Stay in 'front of load', preventing push-pull injuries and the risk of collisions with pedestrians or objects.
- Suitable for retail or industrial environments, including supermarkets where shoppers are pushing trolleys around aisles and passages.
- Can be ordered separately or with the Tug Compact.
- Articulation system can be retrofitted to your existing fleet of trolleys.
- Made to order.

Custom sizes available

The Follow-Me Trolley can also be customised to suit any application. The articulation system can even be retrofitted to your existing fleet of trolleys.

For a hitch that is designed to suit your equipment please refer to page 82.

Please note: We make specialised trolleys to order. This is just one of many designs we have.

Call us today to ask us about our extended range or tell us what you need any we'll quote for you.



Pictured: Standard sized Follow-Me Trolley.

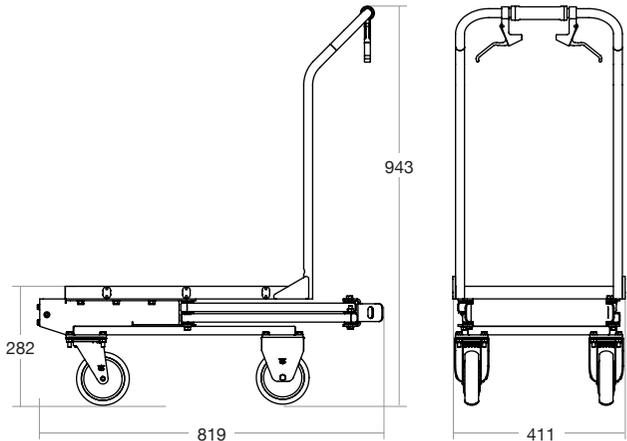

	Order code
Follow-Me Trolley (single trolley)	FOLLOWMETRLY
Tug Compact (no hitch)	TUGCOM500NH
Tug hitch	EDHTFLWMETRLY

Towing a train of trolleys through a store

Problem

A large department store wanted a solution for restocking shelves more efficiently. Their current process was time consuming as it involved a staff member taking a roll cage from the storeroom to a designated aisle in the store, opening and unpacking boxes of stock, filling the shelves, and then returning the roll cage full of empty boxes back to the storeroom. This process was repeated many times across many aisles until all the shelves were stocked.

Apart from being an eyesore, the roll cages also presented a potential injury risk to shoppers if restocking wasn't completed before the store opened. To avoid this situation, staff continually moved roll cages around the store as quickly as possible, increasing the risk of push/pull injuries to themselves.

Needing a more efficient and safer way to deliver stock to the aisles, management decided that they wanted trolleys that could be connected into a train. The train had to be able to easily negotiate the tight corners and passageways throughout store, as well as being easy to hitch and unhitch.

Solution

To address their need, we developed the Follow-Me Trolley, a highly manoeuvrable flat bed trolley with an articulation system inspired by B-Double trailers and road trains.

Designed with a quick hitching mechanism, each trolley can be easily hitched into a train where it mimics the movement of the object directly in front, giving the whole train a very tight turn circle and allowing it to negotiate tight corners and S-bends.

Combined with an Electrodrive powered tug, up to 10 fully loaded Follow-Me Trolleys could be towed safely by one person through the tight confines of the store and delivered at the end of a series of aisles where waiting staff can fill the shelves.

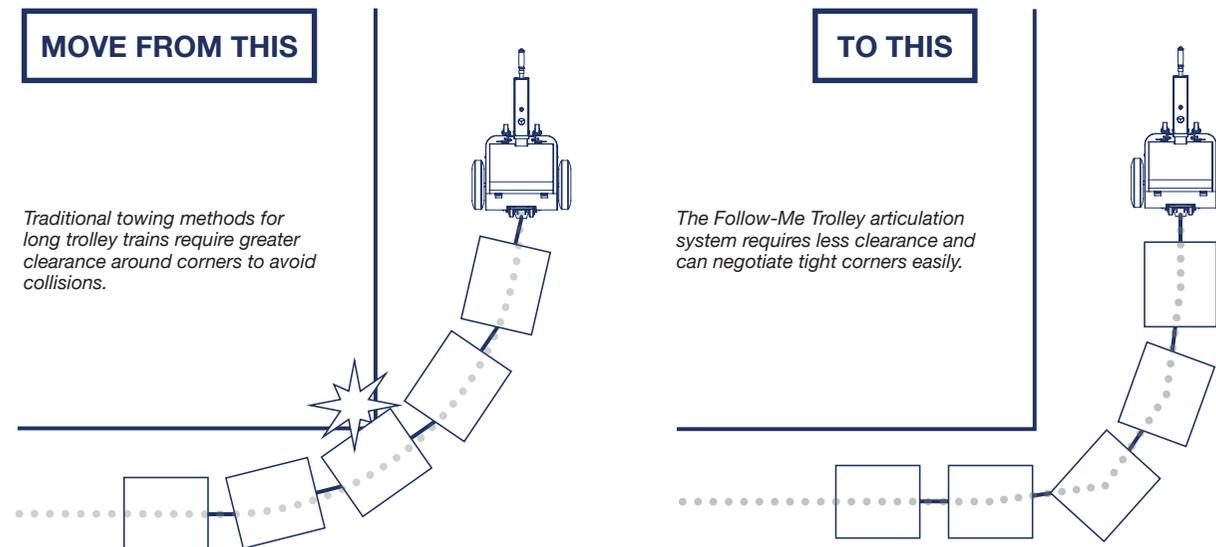

Follow-Me Trolleys in a train easily negotiating an S-bend.

Adjustable feet



Features across the range

- Available in mild and stainless steel.
- Choice of ball joint, bolt-down ball joint, or fixed feet.

Specifications

- Base: Glass reinforced nylon – black.
- Ball: Glass reinforced nylon – black.
- Pad: Synthetic rubber shore 73.
- Stud: Mild steel – plated or stainless steel.
- Nut: Mild steel – plated or stainless steel.
- Maximum adjustable angle (ball joint feet): 20 degrees.

Ball joint feet

Pad diameter (mm)	Pad height (mm)	Thread diameter	Thread length (mm)	Base height (mm)	Max load (kg)	Mild steel code	Stainless steel code
40	20	M8	60	33	350	AF20/40/M8/60	-
	20	M10	60	33	500	AF20/40/M10/60	AF21/40/M10/60
60	20	M12	65	51	800	AF20/60/M12/65	AF21/60/M12/65
	25	M16	65	51	1000	AF20/60/M16/65	AF21/60/M16/65
	25	M16	150	51	1000	AF20/60/M16/150	-
	25	M16	165	51	1000	-	AF21/60/M16/165
90	25	M20	100	51	1000	AF20/60/M20/100	AF21/60/M20/100
	25	M12	65	51	1000	AF20/90/M12/65	AF21/90/M12/65
	25	M16	65	51	1000	AF20/90/M16/65	AF21/90/M16/65
	25	M16	150	51	1000	AF20/90/M16/150	-
	25	M16	165	51	1000	-	AF21/90/M16/165
	25	M20	100	51	1000	AF20/90/M20/100	AF21/90/M20/100

Bolt down ball joint feet

Pad diameter (mm)	Pad height (mm)	Thread diameter	Thread length (mm)	Base height (mm)	Max load (kg)	Mild steel code	Stainless steel code
40	20	M8	60	33	350	AF30/40/M8/60	-
	20	M10	60	33	500	AF30/40/M10/60	AF31/40/M10/60
60	20	M12	65	51	800	AF30/60/M12/65	AF31/60/M12/65
	25	M16	65	51	1000	AF30/60/M16/65	AF31/60/M16/65
	25	M16	150	51	1000	AF30/60/M16/150	-
	25	M16	165	51	1000	-	AF31/60/M16/165
90	25	M20	100	51	1000	A30/60/M20/100	AF31/60/M20/100
	25	M12	65	51	1000	AF30/90/M12/65	AF31/90/M12/65
	25	M16	65	51	1000	AF30/90/M16/65	AF31/90/M16/65
	25	M16	150	51	1000	AF30/90/M16/150	-
	25	M16	165	51	1000	-	AF31/90/M16/165
	25	M20	100	51	1000	AF30/90/M20/100	AF31/90/M20/100

Fixed feet

Pad diameter (mm)	Pad height (mm)	Thread diameter	Thread length (mm)	Max load (kg)	Mild steel code	Stainless steel code
40	20	M8	35	350	AF40/40/M8/35	AF41/40/M8/35
	20	M10	35	500	AF40/40/M10/35	AF41/40/M10/35
60	20	M12	60	800	AF40/60/M12/60	AF41/60/M12/60

Knock-in tube ends

For adjustable feet

These tube ends are designed to be used with adjustable feet, they are not designed to be used with castors.

For adaptors or knock-in tube ends to suit castors, please refer to pages 68 and 69.



Square knock-in tube ends

External tube size (mm)	Internal tube size (mm)	Thread diameter (mm)	Knock-in length (mm)	Max load (kg)	Mild steel code	Stainless steel code	Nylon thread code
19	15-16	M10	22.5	50	AFLTS19/M10		
25	22-23	M10	39	250		AF11/25/M10	AFLTPS25/M10
25	22-23	M12	39	250		AF11/25/M12	AFLTPS25/M12
25	22-23	M16	39	250	AF10/25/M16	AF11/25/M16	
30	26-27	M8	39	350	AF10/30/M8	AF11/30/M8	
30	26-27	M10	39	350	AF10/30/M10	AF11/30/M10	
30	26-27	M12	39	350	AF10/30/M12	AF11/30/M12	
30	26-27	M16	39	350	AF10/30/M16	AF11/30/M16	
32	28-29	M8	39	350	AF10/32/M8	AF11/32/M8	
32	28-29	M10	39	350		AF11/32/M10	AFLTPS32/M10
32	28-29	M12	39	350		AF11/32/M12	AFLTPS32/M12
32	28-29	M16	39	350	AF10/32/M16	AF11/32/M16	
35	31-32	M8	39	350	AF10/35/M8	AF11/35/M8	
35	31-32	M10	39	400	AF10/35/M10	AF11/35/M10	
35	31-32	M12	39	400	AF10/35/M12	AF11/35/M12	
35	31-32	M16	39	400	AF10/35/M16	AF11/35/M16	
38	35-36	M8	41	500	AF10/38/M8	AF11/38/M8	
38	35-36	M10	41	500		AF11/38/M10	AFLTPS38/M10
38	35-36	M12	41	500		AF11/38/M12	AFLTPS38/M12
38	35-36	M16	41	500		AF11/38/M16	AFLTPS38/M16
40	36-37	M10	39	500	AFLTS40/M10	AF11/40/M10	
40	36-37	M12	39	500	AFLTS40/M12	AF11/40/M12	
40	36-37	M16	39	350	AF10/40/M16	AF11/40/M16	
51	47-48	M10	39	750		AF11/51/M10	AFLTPS51/M10
51	47-48	M12	39	750		AF11/51/M12	AFLTPS51/M12
51	47-48	M16	39	750	AFLTS51/M16	AF11/51/M16	
51	47-48	M20	39	750	-	AF11/51/M20	

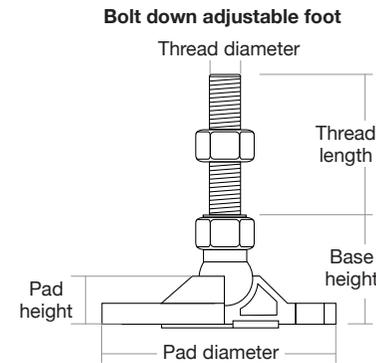

90 mm diameter bolt down adjustable foot

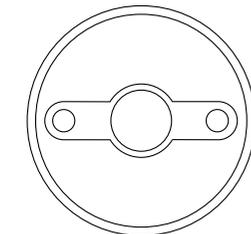

40 mm diameter single hole bolt down flange adjustable foot

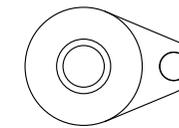

40/60 mm diameter bolt down adjustable foot

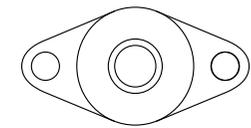

Round knock-in tube ends

External tube size (mm)	Internal tube size (mm)	Thread diameter (mm)	Knock-in length (mm)	Max load (kg)	Mild steel thread code	Stainless steel thread code
25	22	M8	38	100		AF81/25/M8
25	22	M10	38	100	AFLTR25/M10	AF81/25/M10
25	22	M12	38	100	AFLTR25/M12	AF81/25/M12
32	28-29	M8	39	200		AF81/32/M8
32	28-29	M10	39	250	AFLTR32/M10	AF81/32/M10
32	28-29	M12	39	250	AFLTR32/M12	AF81/32/M12
32	28-29	M16	32	250		AF81/32/M16
38	35-36	M10	38	300	AFLTR38/M10	AF81/38/M10
38	35-36	M12	38	300	AFLTR38/M12	AF81/38/M12
38	35-36	M16	38	300		AF81/38/M16
51	47-48	M12	38	450		AF81/51/M12
40	36-37	M10	39	500		AF81/40/M10
40	36-37	M12	39	500		AF81/40/M12
40	36-37	M16	39	500		AF81/40/M16
51	47-48	M12	38	450	AFLTR51/M12	AF81/51/M12
51	47-48	M16	38	450		AF81/51/M16
62	60-61	M16	38	450		AF81/62/M16



Serviced Equipment

Repairs, maintenance and fitting

Serviced Equipment is a leading provider of preventative maintenance and breakdown repair services for a wide range of industries.

Our qualified staff can help you with:

- Preventative and breakdown maintenance of a wide range of electro-mechanical machines like Electrodrive powered movers and Liftmaster bin lifters.
- Electrical testing and tagging.
- Castor fitting and replacement.

Our experienced technicians hold relevant industry qualifications and are certified to perform service work in the healthcare and industrial sectors.

What we do

Industrial and commercial service

We specialise in servicing materials handling equipment (otherwise known as plant items) across a wide range of industrial businesses. Our highly skilled and experienced technicians have the ability to inspect, diagnose and repair almost any fault with materials handling equipment that is typically used as part of a critical business process. This might involve reprogramming a controller on a Tug, installing a drive wheel to a trolley, upgrading or adding new features, replacing worn components, making modifications backed by our Engineering team, rewiring steering controllers, fabricating and customising brand new parts, replacing oil in hydraulic actuators and much more.

Mobility equipment

- Tugs

Back of house

- Bakery equipment
- Deli equipment
- Roll cages
- Stock trolleys
- Flat bed trolleys

Waste handling equipment

- Product display
- Supermarket trolleys
- Bin lifters

Healthcare service

Experience tells us that all healthcare facilities handle the maintenance and repair of equipment differently. Larger hospitals normally centralise their maintenance work through one department that may look after multiple assets for the whole facility. These departments normally outsource their maintenance work to specialist service companies such as ours, who supplement with routine service work and the supply of replacement parts over the long term. On the other hand, smaller healthcare clients, such as aged care homes and day surgeries, may only have a few assets to maintain. This is where reactive “call outs” are better suited and where fast response times and work efficiency are paramount. In both cases, our dedicated service manager will organise the job on your behalf, taking all the work out of solving the problem.

Castors for beds and stretchers

- Clinical beds
- Nursing home beds
- Stretchers
- Gurneys
- Hospital beds

Patient transport and handling equipment

- Mobile floor hoists
- Bed movers
- Wheelchairs
- Power chairs
- Wheelchair movers
- Mobility scooters
- Strollers

Preventative maintenance

Preventative maintenance is a fundamental part of our service delivery. Preventative maintenance is directed towards two basic outcomes:

1. Ensure your mobile equipment is always performing at its peak.
2. Reduce the total cost of ownership of your equipment.

Our preventative maintenance scheduling allows us to be reactive to urgent call outs for breakdown repairs. This makes us lean and efficient and able to cope with jobs both large and small. From completely rebuilding, rewiring or recondition equipment to replacing the wheels and castors on your trolleys, our routine service work keeps equipment working at its peak and reduces downtime for staff who use it. This has a massive impact on productivity and in turn reduces downtime caused by traditional “break/fix” type servicing.

Maintenance methodology

In addition to a number of standard preventative maintenance checks, adjustments and procedures which need to be performed on every visit, the following steps are applied by Serviced Equipment to define a process for targeting specific remedial call-out reduction.

- Produce an accurate and detailed database of remedial maintenance activities.
- Apply regression analysis techniques to identify the distribution of maintenance issues and develop an optimum preventative maintenance strategy.
- Prepare a detailed preventative maintenance schedule and checklist to implement this strategy.
- Produce statistical data to facilitate analysis of the process.
- Review Preventative Maintenance activities quarterly and adjust accordingly.

This is the basis for a successful preventative maintenance implementation. Commercially, these activities ultimately must result in reduced overall maintenance costs and this will be the measuring stick for success.

Preventative maintenance service plans

BRONZE SERVICE

Bronze service

All materials handling equipment sold in this catalogue come with our standard Bronze service package. The service intervals are specified by us and our Field Service Technician will provide the due dates for the next service using a sticker on the instrument panel.

- Six monthly call cycle.
- Online booking service.

This is a 'pay as you go' package and does not include the security of a fixed price service package. Upgrading your Bronze service will reduce service costs over the longer term and avoid downtime from a preventable breakdown.

SILVER SERVICE

Silver service

This is the minimum recommended level of service cover if you have one or more units in the field. It includes the Bronze level service plus:

- Two scheduled services.
- Basic spare parts included—handgrips, levers, cables, springs.

GOLD SERVICE

Gold service

This is the recommended level of service cover if you have one or more units in the field. It includes the Silver level service plus:

- Major spare parts included—gearbox, motor, chain (if applicable), switches, electronics, wheels, castors.

GOLD+ SERVICE

Gold Plus service

This includes all the benefits of the Gold level service plus an extended warranty period of three years.

This level is highly recommended for organisations that have multiple units in the field or for those that have one or more units continually used over three to six month periods.

A fast, reliable and friendly service. Don't risk using someone else!

Serviced Equipment technicians are specially trained to diagnose and repair mobile materials handling equipment using original components without voiding your warranty.

We maintain a complete service history on your behalf. The service history will support the resale value of your asset. Our fixed price service packages are designed to give you the cover you need and give you peace of mind, not surprises.





3040
3040
3040

ANESTHESIA



Fallshaw
GROUP

Fallshaw Group

Mobility solutions to help you push, pull & lift with ease

Our brands include:



Fallshaw

Wheels and castors



Electrodrive

Powered mobility equipment



Waste handling solutions



Materials handling equipment



Repairs, maintenance & fitting

We are a single-source solution provider in mobility solutions. As experts in mindful moving, we help our customers improve safety, productivity and profit in any process that involves pushing, pulling or lifting.

- We work with healthcare, commercial and industrial original equipment manufacturers (OEM) to offer components or complementary products that either reduce the lowest total cost of ownership or provide enhanced product features that increase the saleability or value of their OEM equipment.
- We work with healthcare facilities to improve outcomes in their push-pull processes and patient safety.
- We work with industrial end users to improve their move-safe processes.



How it all began

The Fallshaw Group of companies have engineering roots and proud histories of making products to world standards.

Starting as a wheelchair company in 1920, Percy Fallshaw manufactured wheels and invalid's chairs from a factory in Melbourne.

It was then managed for 45 years by Robert Fallshaw, under whose leadership the company started making castors, developing its manufacturing expertise and building an enviable sales network to make it one of the world's leading castor companies. In 1995, Robert expanded the Fallshaw product range by acquiring Liftmaster Materials Handling and its line of bin lifters.

After Robert's regretful passing in 2005, his daughter Jo took over as the Managing Director and owner, and continues the tradition of developing innovative products, and manufacturing well-designed, cost effective, quality castors, delivered in-full and on-time with great service and technical support.

In 2006, Fallshaw acquired Electrodrive (established in 1987)—with its own proud history in design and manufacture of powered materials handling products. As sales grew and the service division of Electrodrive expanded, we established a new company called Serviced Equipment, utilising the team's expertise in providing repairs, maintenance and fitting, not just for Electrodrive products but for a wider range of powered materials handling equipment as well.





A history of innovation

The group's range expanded further when it was joined by Queensland based materials handling retailers and Fallshaw distributors, Castors and Industrial Products in 2015—bringing with them their expertise in conveying and lifting equipment, and The Wheel & Trolley Shop in 2016 (later renamed to Custom Engineered Solutions) a provider of purpose built mobility solutions.

Today the Fallshaw Group boasts an extensive range of powered and mobile materials handling solutions that are designed to increase productivity while keeping your workplace safe from all types of manual handling injuries. And while not all workplaces and situations are the same, we will create a solution for your particular situation where one does not yet exist.

As experts in mindful moving, we can help our customers improve safety, productivity and profit in any process that involves pushing, pulling or lifting.

We strive for intelligently simple and smart product design, where our mobility products are deceptively simple and elegant, with an interface that is intuitive and easy to use.

Our products are not constrained by traditional approaches and we enjoy doing things differently. We think anew about material selection and manufacturing technology and we radically reinterpret mobility product design.

Take a closer look.
Scan the QR code.



CORE CAPABILITIES

Avoiding collisions

MOVE FROM THIS



TO THIS



CORE CAPABILITIES

Staying in front of load

Towing heavy loads

It is widely accepted that the best way to move a heavy load is by putting it in on wheels. What isn't commonly known is that the safest way of moving a heavy wheeled load, is by towing it with a battery powered tug.

While there are a wide variety of powered tugs on the market to choose from, only Electrodrive tugs are ergonomically designed to keep the operator in front of the load.

Maximise forward visibility

Being in front of the load provides maximum forward vision, reducing the risk of collisions with other people, equipment and structures. An Electrodrive tug features a unique tiller design that helps the operator maintain correct walking posture and reduces the risk of strains to shoulders, arms and wrists from repetitive use.

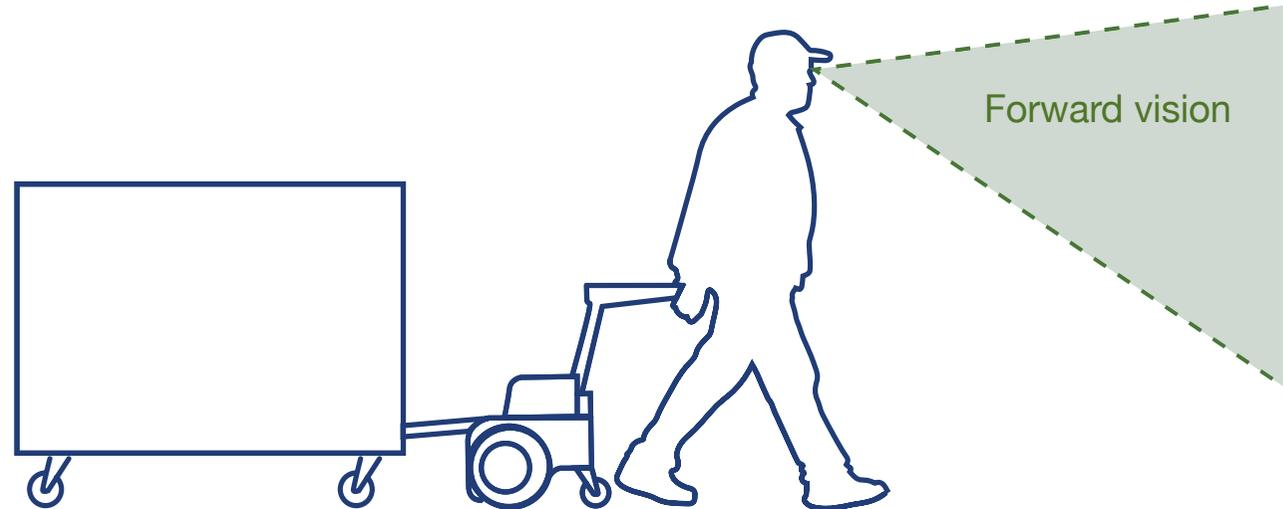

Not all electric tugs are created equal

While it is possible to stay in front of the load with other powered tugs, their butterfly shaped controllers are primarily designed for the operator to grip the handle with both hands and push the load.

If used for towing, the butterfly handle design puts the operator's shoulders, arm and wrist at a very awkward angle. Travelling over any distance in this position is not ergonomic for the operator and could increase the risk of shoulder, arm or wrist strains.

An ergonomic natural walking position

By contrast, the tiller handle drive system on Electrodrive tugs seamlessly interact with how the human body moves while walking, keeping the operator in a comfortable position.

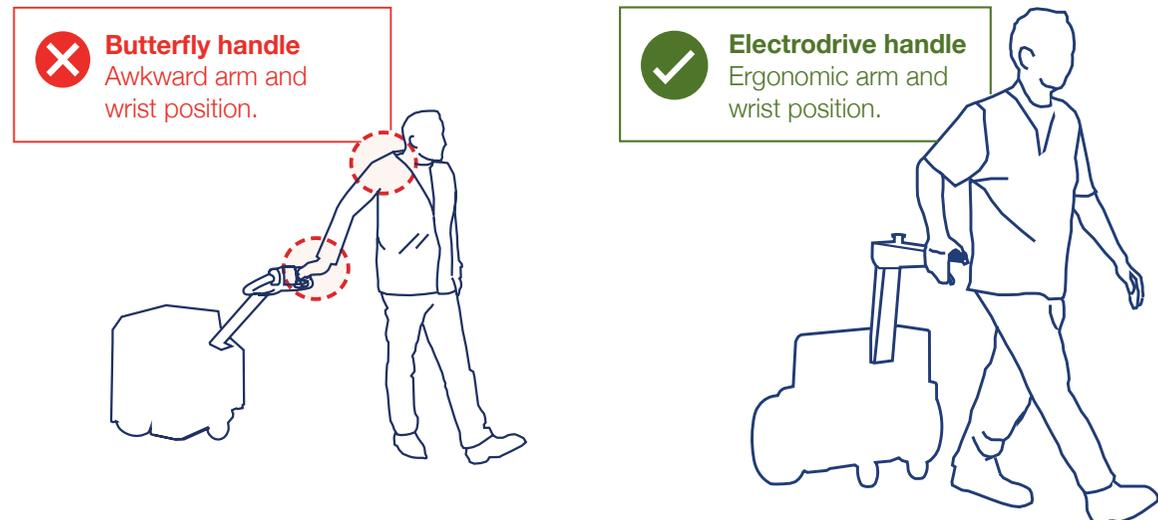



CORE CAPABILITIES

Your move-safe solution in healthcare

Whether you're moving beds, linen, food or waste, Electrodrive can help your staff to stay safe, and demonstrate compliance with the Australian Government's *Hazardous Manual Tasks, Work Health and Safety Code of Practice*.

We are the experts in mindful moving

We work with healthcare facilities to improve safety outcomes in their push-pull processes and patient safety.

We are a single-source solution provider in mobile applications with intelligently simple, smart product design.

We have solutions to prevent push-pull injuries effecting the shoulder, back, neck, arm, forearm/wrist, knee, and hand and fingers.

The cost of doing nothing is huge

The Healthcare & Social Assistance industry suffers more than 17,000 musculoskeletal injuries a year, according to Safe Work Australia (Australian Workers' Compensation Statistics, 2012–13). The median cost of a push-pull injury is \$9,700 with 6 weeks lost. With an annual incidence rate of 12.5 per 1000 employees suffering serious injuries related to injury and musculoskeletal disorders, the cost to a Healthcare facility can be enormous. And of course the personal cost to an injured worker can be devastating.

Known injury risk factors

High forces when manoeuvring wheeled equipment increase the risk of musculoskeletal disorders. Table 1 on the next page offers the best state of knowledge on pushing and pulling, which is based on the work of Snook and Ciriello*. Snook investigated a large number of tasks in which workers had been injured in order to establish the relationship between perceived risk and actual injury occurrence.

Snook's maximum acceptable forces are set out in Table 1, which describes how frequently a worker can push wheeled equipment based on the distance travelled and weight pushed. So, for example, a heavy trolley with 11 kg of sustained push effort can be pushed short distances (7.6 m) every 1 minute, but if you have moderate distances to travel (30.5 m) it is only safe to do this once every 8 hours, and very long distances (61 m+) are not acceptable.

These benchmarks for safe push-pull forces have been adopted as benchmarks within Australia's regulatory environment. But many Australian work places ask staff to push hospital beds or catering and linen trolleys with push effort well above 11 kg for distances and frequencies well above these published government guidelines.

CORE CAPABILITIES

Site assessment and expert advice



Hospital bed undergoing a pull force test

Table: Acceptable frequencies for sustained straight line pushing of wheeled equipment over various distances, handle height 890 mm (Snook and Ciriello 1991).

Distance	2.1 m	7.6 m	15.2 m	30.5 m	45.7 m	61 m
Sustained force	Frequency—75% of female workforce may push wheeled equipment over stated distance once every:					
6 kg or less	6 sec	15 sec	25 sec	1 min	1 min	2 min
7 kg	6 sec	15 sec	25 sec	1 min	1 min	30 min
8 kg	6 sec	15 sec	35 sec	1 min	2 min	8 hr
9 kg	12 sec	15 sec	1 min	2 min	30 min	8 hr
10 kg	12 sec	22 sec	2 min	30 min	8 hr	Not acceptable
11 kg	12 sec	1 min	5 min	8 hr	8 hr	Not acceptable
12 kg	1 min	5 min	8 hr	8 hr	8 hr	Not acceptable

* Source: *A guide to designing workplaces for safer handling of people for health, aged care, rehabilitation and disability facilities—3rd edition, September 2007—Public Sector and Community Services.*

Reducing push-pull injuries is easy ...

... if you work with the experts to redesign your work processes.

The *Hazardous Manual Tasks, Work Health & Safety Code of Practice*, and the related state government industry guideline publications can be so broad that they tell you what the problem is, but offer only vague solutions.

For example, WorkSafe Victoria in their publication *Injury Hotspots Health & Aged Care Services* directs “when pushing and pulling trolleys and wheelchairs, provide equipment that is fit for the purpose and maintained in accordance with manufacturer’s specifications”.

We can help you go from knowing what the problem is, to actually doing something to fix it. We offer actionable solutions with industry best-practice equipment.

The bottom line

Published government guidelines, developed from evidence-based analysis of injuries in the healthcare sector due to pushing and pulling mobile equipment, mandate that pushing a bed, linen cart or meal delivery system is a two-person job unless a motorised solution is utilised.

Complying with the *Hazardous Manual Tasks, Work Health and Safety Code of Practice* makes good business sense as well as being the right thing to do.

CORE CAPABILITIES

Customised castors

Your castor, your way.

Sometimes you just need castors that look different. Whether it's to match a piece of furniture you've designed, to complement your flooring, or just to give your proudly created masterpiece that upmarket touch, we can help you design and build the perfect castor for you.

Because we make our own castors, we can help product designers and manufacturers create their perfect castor with customised colours, wheel materials, fork finish.

We recently helped a leading furniture manufacturer with a total brake castor for their exclusive new lounge collection. With our team's help, we supplied the perfect castor, with colours and elements combined from the Arc, Midnight Black and M Deluxe ranges.

Castors that look the part

A leading manufacturer of high-end wooden furniture needed castors to complement their exclusive range. We supplied a castor that mixed and matched the bright chrome components from the M Deluxe range, the charcoal wheel from the Midnight Black range, and colour-matched a custom colour for the thread guard and pedal.

If you are looking for a particular colourway to match your equipment or furniture, where volume permits, we have a large library of masterbatch colours to choose from. Alternatively we can match any colour from a swatch or a Pantone reference number, ensuring that you'll get the look you want.



Build your own



Charcoal pedal and seal from the **Midnight Black** range

Bright chrome metal components from the **M Deluxe** range

Graphite thread guard from the **Arc** range

Popular colourways

Bronze	Copper	Coffee
Platinum	Ink	Berry



Products designed by you. Castors made by us.



A leading healthcare equipment company wanted a castor to perfectly match the powder-coat colour of their patient lifters and the blue of their company logo. They also required an ultra-low castor for the front of the patient lifter. We matched the colours, and were able to team a wheel with a custom made low-height fork. In addition, we recommended the use of Chicago screw axles (so there are no ankle-biting sharp edges around patients' fragile skin).



A leading design and manufacturing company wanted a castor for a recliner chair that could be activated using purpose-built engagement into a customised pedal (utilising the fixed pedal technology of the Trinity castor). We added engagement holes into the pedal they designed and moulded in their customised colours, materials and finishes, specified for chemical resistance.



A leading hospital bed manufacturer approached us to develop a castor using their corporate colours with a special pintle to suit their specific dimensions. We adapted our O Series castor and developed a special top cap buffer to prevent fluid ingress.

CORE CAPABILITIES

Custom solution specialists

CASE STUDY

Inoperable cars in auto mechanics

Moving heavy inoperable vehicles in automotive workshops is fraught with issues. Most modern SUVs weigh as much as 1.8 tonne and are high from the ground, making visibility difficult for people on the ground.

It always takes more than one person to move a dead vehicle, with:

- One person in the driver's seat.
- The other at the rear of the vehicle pushing with all their might.

In some cases, there are ramps and uneven surfaces at play, so even if you have two people to do the job, it is near impossible for only one person to push it uphill.

Safety risks

This poses serious safety risks for businesses as it leaves open the chance for staff getting injured or even have a fatal accident from a vehicle rolling backwards.

When you add the risk of damaging property or other vehicles from a runaway car it pays to do the research and find a device that is purpose-built to do that task at hand.

Heavy duty tug

We visited a local mechanic in Melbourne and tested our free-standing, heavy-duty five tonne tug in-and-around the workshop using their existing vehicle's tow-hook attachment. This is normally used by tow-truck operators on the side of freeway and is designed as a hitch point at the front of the vehicle to enable them to be "pulled" onto tow trucks.

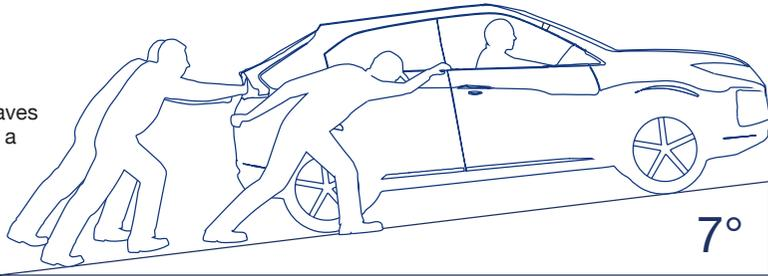

Towing a car up a 7 degree ramp.

Tow hook

Tow hook connected to the tug hitch

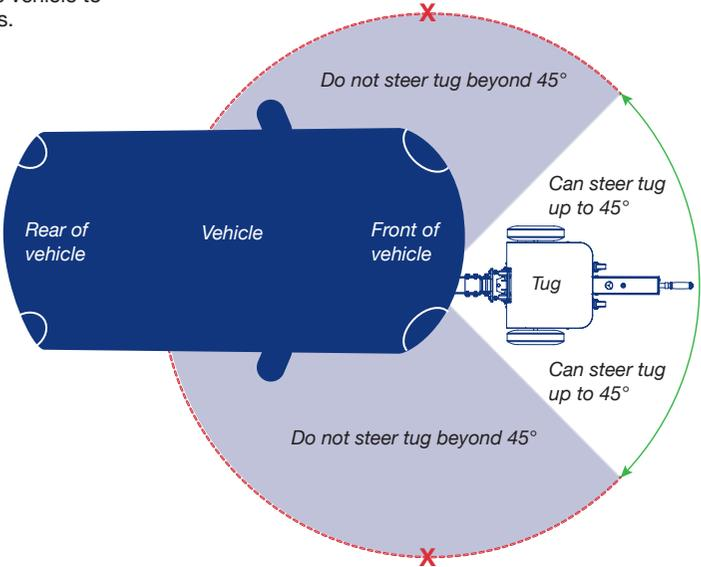

CORE CAPABILITIES

Custom solution specialists

CASE STUDY

A tall order with a tight deadline

Problem

A brand new hospital installed a state of the art automatic guided vehicle (AGV) system to transport linen carts back and forth from the wards to the loading dock, where waiting trucks would take the carts to a commercial laundry, and return with the freshly cleaned linen. However the brand new linen carts (which were customised to fit an AGV passing underneath) were too wide to fit three carts across the width of a truck. The hospital needed to find a way to reduce the widths of the carts before opening day, or face having to pay a third more for trucks and drivers, increasing the hospital's running costs upwards of six figures.

Solution: Ultra slim self-aligning castor

With the hospital opening only eight weeks away, and the new linen carts and AGVs already paid for and delivered, the only components that could be modified were the linen cart castors.

Desperate, the hospital approached us with this tall order. It was a massive challenge but our design expertise and tooling capability allowed us to produce a thinner prototype in just one week. Working with *Fallshaw Wheels & Castors*, we delivered enough ultra slim self-aligning castors to fit the hospital's entire fleet of carts within seven weeks. At just 61.5 mm, it ensured that the hospital could comfortably fit three linen carts across a delivery truck's width, saving the hospital from an increase in running costs.

Pictured: The modified narrower castor top plate (left) had to be 61.5 mm in width, compared to the original 70 mm version (right).



The Continuous Improvement and Tool Room team who produced the prototype within a week of the hospital's request.

Ultra slim self-aligning castor features

- Only 61.5 mm wide.
- Retrofittable to existing carts and trolleys.



An AGV cart with the new ultra-slim castor fitted.

CORE CAPABILITIES

Custom solution specialists

CASE STUDY

Preventing cleaning carts from rolling onto railway tracks

Problem

A cleaning company maintaining train stations needed a solution to stop their unattended cleaning carts from potentially rolling onto railway tracks and into the path of an oncoming train.

Solution: Deadman brakes

The inspiration for the solution came from the same safety technology already found in the trains that travel through. We designed a deadman brake which could be retrofitted to their existing fleet of cleaning carts.

To operate the cart, a person would need to squeeze two levers underneath the handle bars to disengage the brake. When the cart was stationary and levers were released, the brake would activate, stopping the carts from rolling on their own. This eliminated the risk of accidents.

Deadman brake system features

- Retrofittable to your existing carts and trolleys.
- Customisable braking options to suit your trolley design and requirements.

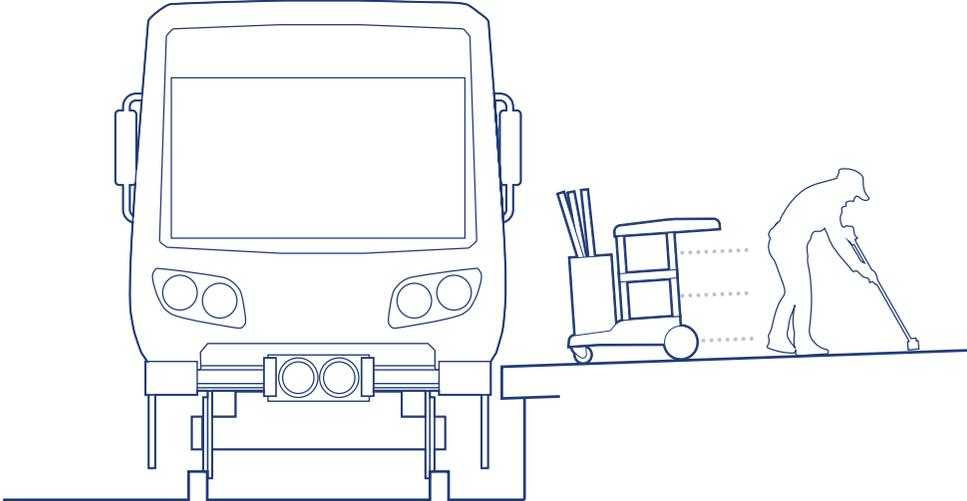

The deadman brake system on a cleaning cart. Squeezing the levers releases the brake and allows the cart to move.

CORE CAPABILITIES

Custom solution specialists

CASE STUDY

Moving and lifting animals

Problem

A veterinarian was looking for a safer way to move their pigs and sheep from their pens to a set of scales for weighing. The current process took five hours to complete and involved up to four people moving all of the animals in and out of pens and onto the weigh scales. The work was physically demanding, carried out in a hot and noisy environment with animals that can be stressed. This presented numerous injury risks to both the staff and animals as they negotiated between the pen and the scales.

Solution: Mobile weigh station

Our team went out to assess the area and produced a mobile weigh station built using equipment and expertise from Castors & Industrial, Fallshaw and Electrodrive.

The mobile weigh station was designed with special safety rails and doors which allowed it to be taken directly to the pen where the animal can walk straight onto the scales, and then back to the pen again. The scales can also be elevated to suit the different platform heights around the area.

With the mobile weigh station, what once took four people, five hours to do, can now be accomplished with two people in just two hours.

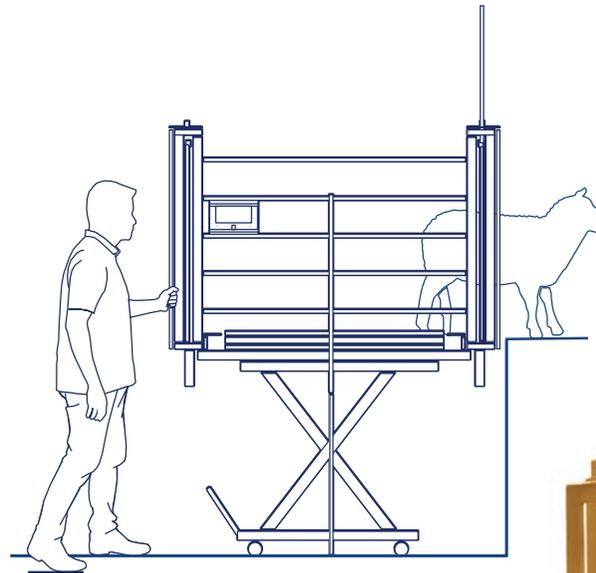

Mobile weigh station features

- Battery powered scissor lift.
- Safety rails and doors.
- Heavy duty castors with brakes.



Information and guides

- Trading policies.
- Conditions of use for castors.
- Delivery policy.
- Test summaries for wheels and castors.
- Test summaries for materials handling equipment.
- Maintenance and fitting.
- Warranty.
- Fork mount dimensions.



Trading policies

Customer satisfaction policy

We improve our services by listening to any customer complaints. Occasionally customers take the trouble to tell us if our service was less than perfect, but most dissatisfied customers simply cease to deal with us—to our loss. We treasure those who complain—it is only through the trouble they take that we can improve.

We undertake to respond to any complaints within two business days.

We believe you will be happy, but if you are not ...

Firstly try to sort it out with our distributor or branch. If you are still unhappy, feel free to contact our Managing Director—Jo Fallshaw directly on +61 3 9300 8542 or email her at jo@fallshaw.com.au. We are determined to maintain a high standard and continuously strive for perfect quality and service.

Reduction of Hazardous Substances (RoHS) statement of compliance

This is a directive of the European Union (Directive 2002/95/EC) that restricts the use of hazardous materials in the manufacture of various types of electronic and electrical equipment. Hexavalent Chromium is one of these chemicals and has been traditionally used in the zinc plating industry. We hereby certify that our products (sold under the Fallshaw brands*) comply with RoHS regulations and do not contain the following banned substances:

- Lead
- Polybrominated Biphenyls
- Pentabromodiphenyl ether (PentaBDE)
- Mercury
- Cadmium
- Polybrominated Diphenyl Ether
- Octabromodiphenyl ether (OctaBDE)
- Hexavalent Chromium.

* For special-ordered products or products sold under other brands, please inquire about RoHS compliance prior to ordering if this is important to you, and we will research the RoHS compliance or otherwise of the particular item concerned and provide a separate written statement.



CERTIFICATE OF REGISTRATION

ISO 9001
CERTIFIED
QUALITY
MANAGEMENT

FALLSHAW HOLDINGS PTY LTD
 ABN: 74 005 237 525
 Locations as specified on Appendix 1

has been independently assessed and certified as having established, documented and implemented a Quality Management System complying with the requirements of

ISO 9001:2015

Quality Management Systems

The scope of certification covers the design, manufacture and distribution of Fallshaw Wheels and Castors and the design, manufacture, sales and service of materials handling equipment.



W.A. Cullinan
Chairman – Approval Panel



R.M. Newbery
Co-Signatory – Approval Panel

Certificate number: 315111-Q1
Current issue: 01/08/2022

Initial certification: 11/12/2015
Certificate expiry: 31/05/2025



Certification & Training



www.jas-anz.org/register



www.iaf-certs.com

ECAAS Pty Ltd
A.C.N 104 429 898
www.eccas.com
GPO Box 1818
ADELAIDE, South Australia 5001



CERTIFICATE OF REGISTRATION

ISO 9001
CERTIFIED
QUALITY
MANAGEMENT

ELECTRODRIVE PTY LTD
 ABN: 68 006 805 232
 Locations as specified on Appendix 1

has been independently assessed and certified as having established, documented and implemented a Quality Management System complying with the requirements of

ISO 9001:2015

Quality Management Systems

The scope of certification covers the design, manufacture and distribution of Fallshaw Wheels and Castors and the design, manufacture, sales and service of materials handling equipment.



W.A. Cullinan
Chairman – Approval Panel



R.M. Newbery
Co-Signatory – Approval Panel

Certificate number: 315111-Q2
Current issue: 01/08/2022

Initial certification: 11/12/2015
Certificate expiry: 31/05/2025



Certification & Training



www.jas-anz.org/register



www.iaf-certs.com

ECAAS Pty Ltd
A.C.N 104 429 898
www.eccas.com
GPO Box 1818
ADELAIDE, South Australia 5001

Conditions of use for castors

Although manufactured in Australia, Fallshaw Wheels & Castors have adopted the general safety standards and conditions of use defined in the *European Union General Product Safety Directive (GPSD) 2001/95/EG (harmonized with the German Law of Liability for Products Prod-HaftG)* as this directive has more extensive product requirements additional to the general requirements of the *Australian Competition and Consumer Act 2010*. Please be advised that our manufacturer's warranty is subject to observing the following information. Deviation from this information will release Fallshaw Wheels & Castors from the manufacturer's liability.

1.0 Product information and determined use

Wheels and castors are defined as constructional parts that are generally interchangeable.

They are fitted to apparatus, furniture, transport systems or similar products to make them mobile.

This product information refers to castors and wheels, particularly to swivel castors (not steer castors) which are used on non-powered equipment at a speed not exceeding walking pace and not being under continuous motion.

Castors and wheels according to this product information, can be divided into the following categories of application:

- Domestic use—such as seating and furniture.
- General services—such as shopping trolleys and office equipment.
- Health care services—such as hospital beds and patient trolleys.
- Industrial purposes—such as transport equipment with medium and heavy duty load bearing capacities.

Our products will give a long and trouble-free life if the following criteria are adhered to:

1. Correct and secure fitting at the designed position.
2. The fitting must have adequate strength and material for a secure fitting.
3. The function of the castor must not be changed nor affected by the fitting.

4. The swivel action axis must be vertical at all times.
5. Fixed castors must have their wheel axles perpendicular to the direction of travel.
6. If only swivel castors are used, they must be common to each other. If fixed castors are used in conjunction with swivel castors then all castors must be compatible and recommended by the manufacturer.

If castors are used in corrosive environments such as outdoors, coastal areas, corrosive and/or aggressive areas (like chicken farms), and where castors have cleaning regimes requiring water resistance of greater than IPX4, and where castors are exposed to caustic substances, special products have to be specified. See the chemical resistance chart on page 47 for a clear indication of suitability.

For use in temperatures below 5°C and above 30°C, the performance of the castor can be impaired, particularly the normal load capacity as published can be affected when used in temperatures below/above those stated herein. Special products can be specified (see pages 53 to 55).

2.0 Misuse

The word 'misuse' is defined as:

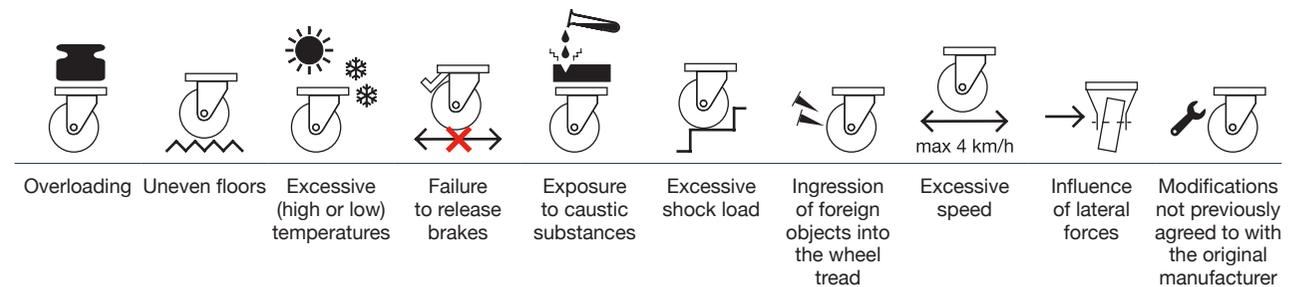

3.0 Product capability

Should the user not find a product clearly described in the manufacturer's catalogue, leaflets or descriptive literature, then any new castor designed for the particular application has to be fully agreed with the manufacturer. Any new designs effected will be subject to the relevant standards (ISO, IEC, etc).

4.0 Maintenance and cleaning

Regular maintenance of castors is required in order to maintain the warranty (as defined in the 'Maintenance and Fitting' section of this catalogue).

Should any cleaning agents be used, then these same agents should not contain corrosive, nor grinding elements. Our products are rated to IPX4 unless otherwise stated on the product page, therefore cleaning with high pressure water (especially if the water is mixed with caustic chemicals and forced into the castor thereby displacing grease or forcing water past seals) will void the warranty. Cleaning should be conducted by following the correct dilution ratio for the cleaning detergent and wiping with a damp cloth.

Delivery policy

Fallshaw's factory and main stock holding is in Sunshine, Victoria (Melbourne, Australia). We also carry stock holdings in Silverwater New South Wales, and Stapylton Queensland.

We have a national freight policy, whereby we subsidise freight prices from Melbourne to other Australian destinations so that there is no price disadvantage to receiving stock direct from Melbourne rather than from a local branch. This helps us to prevent double-handling and thereby reduce costs. This keeps our prices competitive for all our customers.

This Despatch Policy is the lead time to despatch an order that our sales people can commit to without making separate inquiries to the Production & Assembly Factory. We ensure we have sufficient stock and manufacturing capacity to reliably deliver against these lead times. We can often do better on request, but you'll need to check first. We can also provide customised replenishment and stocking solutions for our account customers, when particular high-volume products are required on an ongoing basis (so goods are packed and ready to be called up against a firm order).

If an order is placed *before* 10am (Melbourne time), goods are available for collection or despatch from 3pm until 4pm the *same day*, and anytime the day after.

If an order is placed *after* 10am (Melbourne time), goods are available for collection or despatch from 12pm until 4pm the *next day*, and anytime the day after that.

Express freight options available on request. All days are business days. WA freight departs on Tuesdays and Fridays.

* Excludes Self-Aligning Castors. These castors are not a stocked item due to highly variable demand. Manufactured to order with lead time determined upon request.

Despatch lead times for order quantities

Product group	1-50	51-100	101-300	301-500	>500
Fallshaw General castors (Light to medium duty, general duty and heavy duty)	Same day	2 days	3 days	8 days	Determined upon request
Fallshaw Wheels	Same day	2 days	3 days	8 days	Determined upon request
Fallshaw Pneumatics	Same day	2 days	8 days	Determined upon request	
Fallshaw Fitting & spares	Same day	2 days	3 days	8 days	Determined upon request
Product group	1-12	13-20	21-50	51-150	>150
Fallshaw Decorative castors	2 days	2 days	8 days	Determined upon request	
Fallshaw Medical castors & wheels	2 days	2 days	8 days	Determined upon request	
Fallshaw Specialised castors*	2 days	2 days	8 days	Determined upon request	
Fallshaw General castors (Very heavy duty: W and X series)	2 days	2 days	Determined upon request		
Fallshaw General castors (Very heavy duty: V and A series)	2 days	Determined upon request			
Product group	1-2	3-5	6-10	11-20	>20
Electrodrive Powered mobility equipment	5 days	10 days	Determined upon request		
Liftmaster Waste handling equipment	5 days	10 days	Determined upon request		
Castors & Industrial Materials handling equipment:					
Adjustable feet and knock-in tube ends	Same day	Same day	Same day	Same day	Same day
Hand trucks, safety steps & drum handling	Same day	3-4 days	3-4 days	3-4 days	3-4 days
Industrial trolleys, mobile scissor lifts and pallet trucks	Same day	3-4 days	Determined upon request		
Conveyors (except standard galvanised and polypropylene rollers: same day)	8-10 days	8-10 days	8-10 days	8-10 days	8-10 days
Pallet positioners	Same day	3-4 days	3-4 days	6-8 weeks	6-8 weeks
Container skates	3-4 days	6-8 weeks	6-8 weeks	6-8 weeks	6-8 weeks
Lift tables	6-8 weeks	6-8 weeks	6-8 weeks	Determined upon request	
Battery powered mobile scissor lifts	3-4 weeks	3-4 weeks	3-4 weeks	Determined upon request	

Test summaries for wheels and castors



Applicable standards and test methods	Dynamic test	Brake life	Static load test	Impact test	Brake effectiveness
Hospital bed castors IEC60601-2-52 <ul style="list-style-type: none"> Central locking Trinity & Trinity EBC 	1x load capacity with 2.88 km/h speed. Obstacle height 20 mm, 80 mm wide, 90° to travel, 1.5 mm radius on edge. Dynamic run of 10x forward and reverse bumps over obstacle.	Apply brakes 10,000 times without brakes failing.	Apply 3x load capacity for 1 hour. No deformation after 24 hours elapsed time.	N/A	1x load capacity at 10° incline with brakes on. Slippage must be < 10 mm.
Castors for furniture AS1961.3-2004 (ISO 22879:2004) <ul style="list-style-type: none"> Castors with a diameter of 50 mm or less 	Apply 125% of load capacity, 2 mm bump, space 500 cycles, 6.5 cycles/min.	N/A	Apply 2x load capacity for 24 hours. No deformation after 24 hours elapsed time.	30 kg load capacity: 5 kg from 200 mm free fall drop. 40 kg load capacity: 5 kg from 300 mm free fall drop. Proper function (minor deformation allowed).	Load castor to 1x load capacity, then apply horizontal force of 20% of load capacity without brakes allowing wheel to swivel.
Castors for manually propelled equipment for institutional applications—AS1961.5-2004 (ISO 22881:2004) <ul style="list-style-type: none"> Light to medium duty ranges (excluding Economy and castors with diameter < 50 mm) 	1x load capacity at 3 km/h speed. Obstacle height 3% of wheel diameter and with a radius 1/3 of height. Number of obstacles to be 10 times x wheel diameter in mm distance apart 1–3m. Initial swivel play less than 4 mm (measured at 200 mm); final swivel play < 8 mm.	Apply brakes 5,000 times without brakes failing.	Apply 1.5x load capacity for 1 hour. No deformation after 24 hours elapsed time.	N/A	Load castor to 1x load capacity, then apply horizontal force of 20% of load capacity without brakes allowing wheel to swivel.
Applications up to 1.1 m/s (4 km/h)—AS1961.7-2004, ISO 22883:2004 <ul style="list-style-type: none"> General to heavy duty castors 	1x load capacity at 4 km/h speed. Obstacle height: 2.5% of wheel diameter > 90 shore A; 5% of wheel diameter < 90 shore A. Number of obstacles to be 500 and to be 1 m apart, then remainder of 15,000 revolutions of the wheel without obstacles. Initial swivel play < 4 mm (measured at 200 mm). Final swivel play < 8 mm.	Apply brakes 5,000 times without brakes failing.	<p>ABOUT THE BRAKE EFFECTIVENESS TEST</p> <p>The ISO brake effectiveness tests are extremely harsh. They exist to ensure that brakes are ramp-capable by measuring brake traction force. However this greatly reduces the load capacity of the castor that is otherwise appropriate in safely complying with the ISO Static, Dynamic and Impact tests.</p> <p>At Fallshaw, our approach is to rate the castor for normal use on flat surfaces. However if your application involves brake application on ramps or inclines then you MUST reduce the catalogue load rating by 0–40% in order to comply with the ISO brake effectiveness test (except in hospital bed castors which are fully compliant at published ratings).</p>	Load castor to 1x load capacity, then apply horizontal force of X% of load (3 times x 10 seconds) without brake allowing wheel to swivel. X=10% for tyre hardness > 90 shore A X=15% for tyre hardness < 90 shore A.	
Applications over 1.1 m/s (4 km/h) and up to 4.4 m/s (16 km/h) ¹ —AS1961.8-2004 (ISO 22884:2004) <ul style="list-style-type: none"> Very heavy duty castors (excluding Economy range) 	1x load capacity at 6 km/h speed (bumps 1 m apart) and 10 km/h speed (bumps 1.5 m apart). Obstacle height: 2.5% of wheel diameter for tyre hardness > 90 shore A; 5% of wheel diameter < 90 shore A. Number of obstacles at 5 times the wheel diameter. Initial swivel play < 3 mm (measured at 200 mm). Final swivel play < 6 mm.	Apply brakes 5,000 times without brakes failing.		Load castor to 1x load capacity, then apply horizontal force of X% of load (3 times x 10 seconds) without brake allowing wheel to swivel. X=10% for tyre hardness > 90 shore A X=15% for tyre hardness < 90 shore A.	

* The ISO standard for dynamic testing specifies 3 min ON/1 min OFF or 2 min OFF or 3 min OFF. However, we test 3 min ON 3 min OFF in applications where excessive heat build up would not be experienced in the field and is not a failure mode. Change direction each cycle. Obstacles at 45° alternating left/right.

¹ Note that we only provide castors for towing up to 10 km/h.

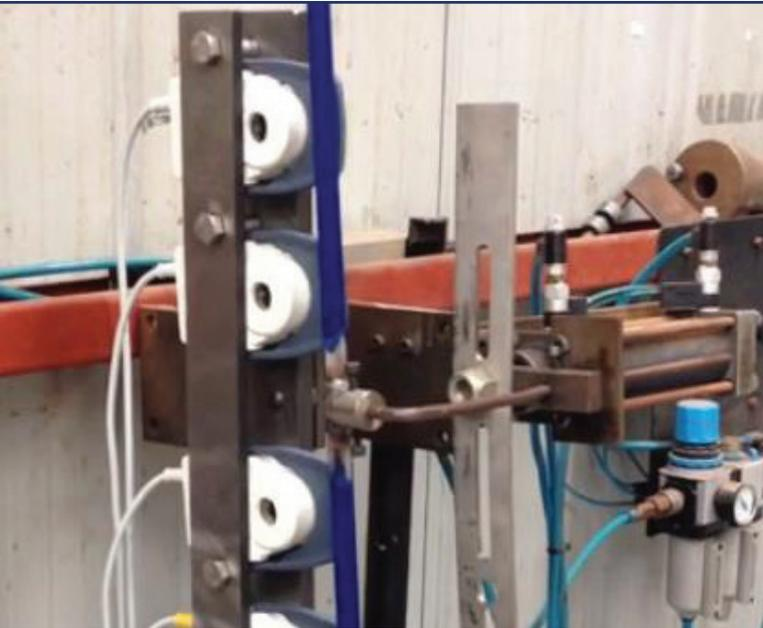

Other standards relevant to Fallshaw products

- Shopping trolleys—For general use—AS/NZS 3847.1:1999
- Shower/toilet chairs (mobile and static)—AS/NZS 3973:2005
- Neutral salt spray (NSS) test—AS2331.3.1-2001
- Powder-coating adhesion—AS1580 Method 408.4

And that is only the beginning

We often develop tests in conjunction with our customers to replicate the harsh conditions or long life cycle expectations that will be experienced by products in real world conditions. We can then supply evidence of testing in video format as well as formal test reports.

Here's one of our favourite examples. One of the 25 tests that Trinity EBC has to pass to meet our standards, is a Long Life Brake Cycle Test. The Trinity EBC has a brake designed for 60,000 brake ON/OFF cycles and we conduct this test over 100 hours, ensuring that Trinity EBC will continue to be dependable out in the field.

3.2 Long Life Brake Cycle Test (60,000 on/off) – EBC Only

Individual Test Report No. – 56468, 56482, 56490

Test Requirement

- No of Cycles: Mechanical Brake on/off 20,000 cycles (headrace only)
- No of Cycles: Electrical Brake on/off 40,000 cycles (full castor, feedback system monitored)
- Test Load: 150kg on test trolley (4 castors)
- Rate: 10 Cycles / Minute
- Duration: 100hrs
- Pass Criteria: Fully operational braking system to ISO 22882 at the completion of test, including all EBC functions and no greater than 0.5% failures detected by feedback system.

1. IEC 60601-2-52 Testing
 - 1.1 Threshold Test
 - 1.1.1 EBC
 - 1.1.2 Trinity 100 (4")
 - 1.1.2 Trinity 125 (5")
 - 1.1.3 Trinity 150 (6")
 - 1.2 Instability in Transport - Ramp Test
 - 1.2.1 Trinity 100 (4")
 - 1.2.3 Trinity 125 (5")
 - 1.2.4 Trinity 150 (6")
 - 1.3 Cable Pullout Test – EBC Only
 - 1.4 Cable Torque Test
2. ISO 22882 (AS 1961.6 2004, EN 12531:1998) Hospital Castor Testing
 - 2.1 Braking Fatigue Test (10,000 on/off)
 - 2.1.3 Trinity 100mm and 150mm
 - 2.1.4 Trinity EBC
 - 2.2 Wheel Braking Test
 - 2.3 Swivel Braking Test
 - 2.3.1 Tested in Total Brake
 - 2.3.2 Tested in Direction Lock
 - 2.4 Static Load Test
 - 2.5 Dynamic Run Test
3. Fallshaw Inhouse Testing
 - 3.1 Long Life Run Test (30,000 Obstacles)
 - 3.1.1 Trinity 100 Pintle and washer mount
 - 3.1.2 Trinity T125 Pintle and washer mount
 - 3.1.2 Trinity 150 EBC
 - 3.1.3 Trinity 150 washer mount
 - 3.1.4 Trinity 150 Pintle Mount
 - 3.2 Long Life Brake Cycle Test (60,000 on/off) – EBC Only
 - 3.3 Dynamic Brake Test – EBC Only
 - 3.4 Side Impact
 - 3.4.1 Tested in Direction Lock
 - 3.4.2 Tested in Total Brake
 - 3.5 Pedal Impact
 - 3.6 Castor Impact
 - 3.7 Linear Swivel Test
 - 3.8 Dynamic Run Test
 - 3.9 Individual Swivel Resistance Test
 - 3.10 Mounted Rolling/Swivel Resistance
 - 3.11 Brake Usage Life Cycle Test – EBC Only
 - 3.12 Intuitive Steer Test
 - 3.13 Direction Lock Side Drag Test
 - 3.14 Direction Lock Bump Test

Test summaries for materials handling equipment

Relevant legislation and regulations for all powered materials handling equipment (bin lifters, tugs and bed movers)

- Occupational Health and Safety Act 2004 [OH&S Act s40(2)].
- Occupational Health and Safety Regulations 2007 [OH&S Regulations Part 3.5, 6.2.1–6.2.8, Part 1, Schedule 2].
- Equipment (Public Safety) Regulations 2007 [EPS Regulations 801-806, Schedule].
- AS 3000: Wiring Rules.
- AS 1319: Safety signs for the occupational environment.
- AS 1431: Low Voltage Switchgear and Control gear—Control circuit Devices and Switching Elements.
- AS 1775: Low Voltage Switchgear and Control Gear.
- AS 1939: Classification of degrees of protection provided by enclosures for electrical equipment (IP code).
- AS 2005: Fuses with enclosed fuse links.
- AS 2467: Maintenance of electrical switchgear.
- AS 2700: Colour standards for general purposes.
- AS/NZS 3000: SAA Wiring Rules.
- AS/NZS 3008.1.1: Electrical Installations—selection of cables.
- AS 3147: PVC insulated electric cables and flexible cables for working voltages of up to and including 0.6/1 kV.
- AS 3193: Transformer type battery charges.
- AS/NZS 4836: Safe working on low-voltage electrical installations.
- ASC 320: Classification of insulating materials for electrical machinery and apparatus on the basis of thermal stability in service.

Tugs

- AS2359—Powered industrial trucks (AUST)
- AS4024—Safety of machinery (AUST)
- ANSI/ITSDFB56.9-2007, Safety Standard Operator Controlled Industrial Tow Tractors
- (US) Directive 2006/42/EC (EURO)
- AS 1554.1:2011—Structural Steel Welding



Bed movers

- IEC60601-1
- IEC60601-2-52
- Medical Device Directive (93/42/EEC) (EURO)
- AS 1554.1:2011—Structural Steel Welding



Bin lifters

- AS4024—Safety of machinery (AUST)
- AS 1554.1:2011—Structural Steel Welding



Production Testing	Tugs	Bed movers	Bin lifters
Pre-assembly	Bench testing of critical electro-mechanical components including motors and actuators.	Bench testing of critical electro-mechanical components including motors and actuators.	Bench testing of critical electro-mechanical components including motors and actuators.
In process	Current draw test during assembly on electro-mechanical components.	Current draw test during assembly on electro-mechanical components.	Load testing. Cycle testing of hydraulic system. Inspection of fluids.
Pre-delivery	Output performance check <ul style="list-style-type: none"> • Record speed & check speed chart. • Record load test & check load chart. • Check appropriate labels are fitted. 	Output performance check <ul style="list-style-type: none"> • Record speed & check speed chart. • Record load test & check load chart. Check appropriate labels are fitted.	Check for fluid leaks. Test limit switch function. Check appropriate labels are fitted.
In service	Diagnostics check. Functional assessment check.	Diagnostics check. Functional assessment check.	Functional assessment check. Review for worn parts.

Maintenance and fitting

Under average conditions of intermittent use, Fallshaw castors will run for five years without maintenance. If the castors are in constant use, this reduces to one year.

Correct fitting

Castors will not swivel properly unless they are mounted vertically. Otherwise they will track to one side.

Heavy trolleys need plate mountings, but the base of the trolley must be strong enough to withstand the load. Never mount a plate castor by three bolts only. Never skimp on the mounting base.

You can get up to 8 mm of adjustment with washers, or an off cut of tube tightly jammed between leg and castor—but do not let it float. Tighten tubular fittings firmly, but do not over-tighten.

You should retighten castors after three months of use, and annually after that. We recommend ‘three finger’ tightness—the amount of torque you can get onto a standard spanner using your three middle fingers.

Tube fittings

Medium duty castors are often mounted into tubular legs. But again, it is important that these legs stay vertical.

We recommend that the leg never extend more than 125 mm below the nearest support, and (apart from the lightest uses), the tube should be 1.4 mm thick or more. Thinner gauges often split. If you wish to use lighted gauge in the rest of the trolley, insert a sleeve for at least 150 mm where the castor is mounted.

Never put a round expanding fitting into a square tube as when the trolley hits a bump, the tube is likely to elongate, and the castor may fall out. We do have square fittings, and ask that you use them. If for some reason you need to put round into square, then weld an insert sleeve of round tube (remember—our smallest fitting needs 3/4" ID). When using Directional Lock (DL) type castors it is best to use the solid swivel stem and weld or bolt it in—screwed types can become misaligned. To achieve the best performance from the larger 175 mm and 200 mm castors use solid stems.

When fitting expanding stem castors, make sure that the fitting is fully inserted into the tube, with the tube firmly down onto the castor head rivet, before tightening it up (you may have to remove some of the burr on the inside of the tube before you try

to push the fitting in). After making sure the weld on the inside of the tube is not excessive, align it with one of the slots down the outside of the adaptor fitting. Put the fitting into the tube all the way, then put some sideways pressure on to it to help the fittings grip, then tighten the stem bolt firmly. Do *not* over-tighten, or you will make it hard to remove later. It is advisable that any tube fitting on expanding stem castors be checked after the first three months, and then yearly to make sure the tube fitting is fully and firmly into the tube and the tightening nut is firmly but not over tightened.

Greasing

Grease in both the swivel head race and the wheel serve three purposes:

- Prevents rusting of the balls and raceways.
- Prevents galling.
- Reduces noise.

It does not need a lot of grease to do this. Too much is unsightly and only attracts dust. A liberal smear is all that is needed. If you only have a few castors to grease, use your finger to apply the grease, then wipe off the excess with a rag or use a needle tip grease gun.

If you have many of them we suggest the following:

- Turn the trolley upside down and remove the wheels.
- Re-grease the head, either through the grease nipple if fitted, or by a needle tip fitting on a grease gun. You will need to lift the seal on the heavier range of castors with a sharp pointed screwdriver. Two full squirts are usually adequate, but make sure enough grease gets through to the centre so it can descend to the bottom race.
- Check the wear of the axle bushing. Reuse if not heavily worn, otherwise replace. Smear about a teaspoon of grease along the inside of the wheel bearing with your finger, taking care to force the grease up into the rollers and reassemble.
- Be careful of the lip seal on the wheel as you reinsert the axle bushing into the roller bearing wheels. Make sure the axle bushing is clean as you reinsert it.
- Reassemble the wheel into the castor. Replace washer where fitted. A drop of *Loctite High Assembly Strength* solution on the axle thread is a good precaution.
- Use a No. 2 bearing grease (not sodium based).



Wheel bearings

Any slackness present in plain bearings or roller bearings can often be improved by replacing the axle bushing. If necessary, the plain or roller bearings can be replaced as well. Often simply re-greasing B type bearings is enough, though they can also be replaced if necessary. Sealed precision Q type bearings seldom wear sufficiently enough to need attention.

Warranty

Our products are warranted against defects in materials or workmanship for the following periods:

Fallshaw general castors

- 3 years

Fallshaw decorative castors

- 3 years

Fallshaw medical castors and wheels

- Trinity series (including Trinity Electronic Braking Castors)—3 years
- Central locking castors—3 years
- Conductive wheels—3 years
- Wheelchair castors—3 years

Fallshaw specialised castors

- M Stainless steel—3 years
- O Stainless steel—3 years
- M Powder-coat—12 months
- High/Low temperature—12 months
- Self-aligning—3 years
- Supermarket trolley and travelator castors—12 months

Fallshaw wheels

- Soft—3 years
- Polyurethane—3 years
- Hard—3 years
- Pneumatics and puncture-proof—12 months

Fittings and spares

- Fittings—3 years
- Spares for pneumatics and general wheels—12 months
- General spares—3 years

Electrodrive powered mobility equipment

- Unit—12 months
- Battery—6 months

Liftmaster waste handling solutions

- Unit—12 months
- Battery—6 months

Castors & Industrial materials handling equipment

- Unit—12 months
- Battery—6 months

Serviced Equipment repairs, maintenance & fitting

- Parts excluding batteries—12 months
- Battery—6 months
- Repairs—6 months

Any product that fails within the warranty period will be replaced with an equivalent product, delivered to the customer's store free of charge and freight cost. The warranty does not extend to the fitting of the product. The website, catalogue and operating manuals specify the conditions of use, installation and maintenance for our products. Customers should choose, use and maintain our product according to our recommendations, or they may become unsafe or product life could be compromised, and our liability may be voided.

This warranty excludes the effects of fair wear and tear, abuse, misuse, improper installation and inadequate maintenance. In unusual or severe applications not clearly similar to those on the website or in the catalogue, the customer is invited to submit a written description of the application against which we will make a recommendation, and which will form a part of the acceptable use conditions of the recommended product. If our catalogue is unclear, or if your application is not clearly covered by the examples given in the catalogue, we ask you to contact our staff for advice. We want to help, and we have the technical information to share if we know your needs.

Fork mount dimensions

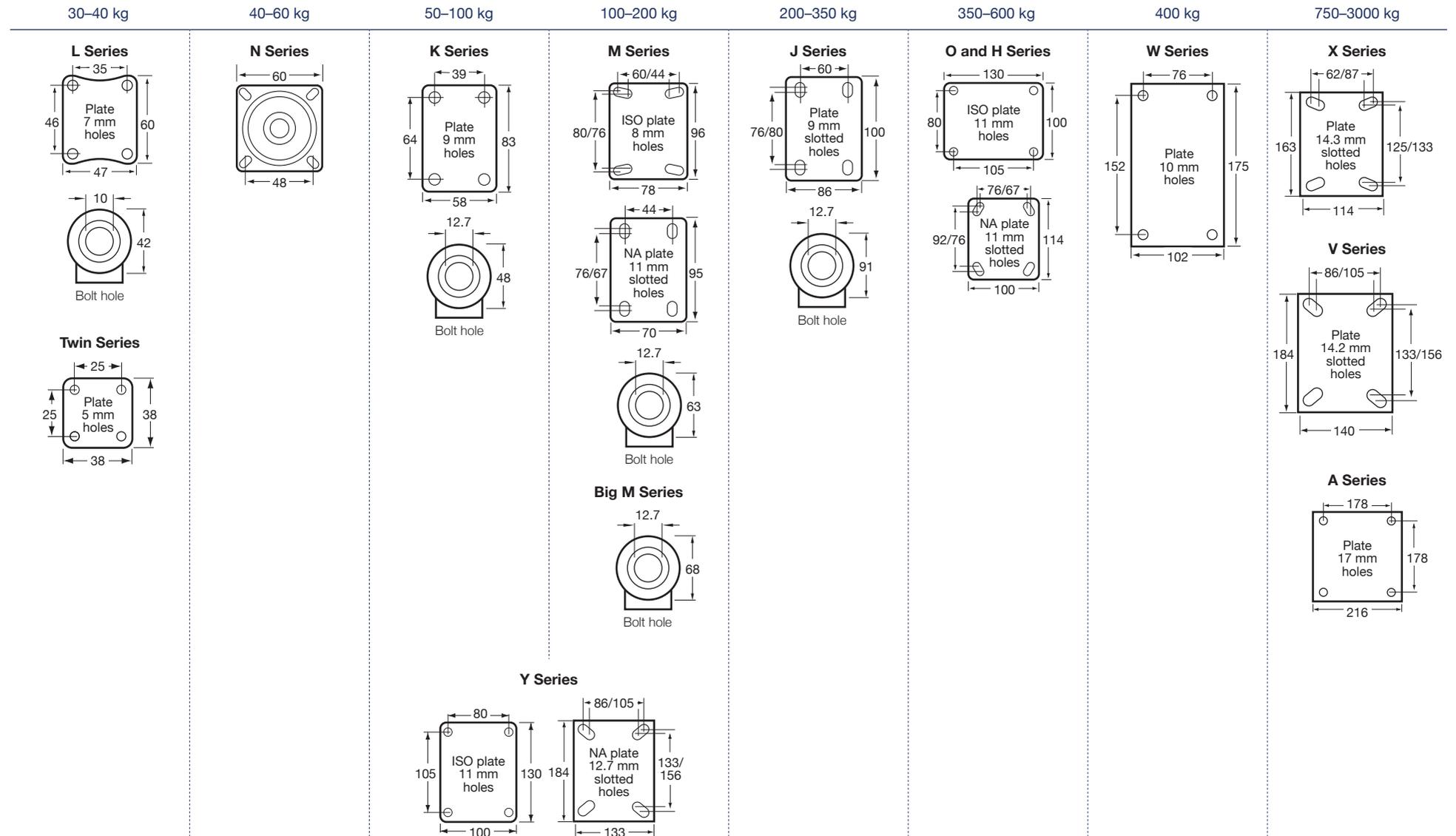



Fallshaw
GROUP



www.fallshawgroup.com.au

1300 934 471 (within Australia) or +61 3 9300 8555 (outside Australia) • sales@fallshaw.com.au